

SMD Type MOSFET

MOS Field Effect Transistor  
2SJ602

Features

- Low on-resistance  
 $R_{DS(on)1} = 73\text{ m}\Omega\text{ MAX. (}V_{GS} = -10\text{ V, }I_D = -10\text{ A)}$   
 $R_{DS(on)2} = 107\text{ m}\Omega\text{ MAX. (}V_{GS} = -4.0\text{ V, }I_D = -10\text{ A)}$
- Low  $C_{iss}$ :  $C_{iss} = 1300\text{ pF TYP.}$
- Built-in gate protection diode

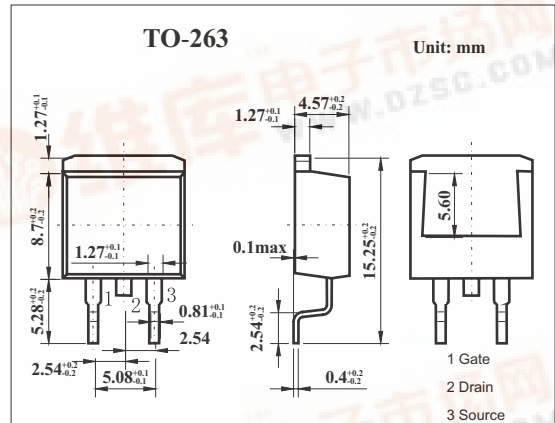
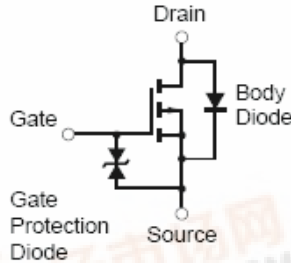

Absolute Maximum Ratings  $T_a = 25^\circ\text{C}$

Parameter	Symbol	Rating	Unit	
Drain to source voltage	$V_{bss}$	-60	V	
Gate to source voltage	$V_{gss}$	$\pm 20$	V	
Drain current (DC)	$I_D$	$\pm 20$	A	
Drain current(pulse) *	$I_D$	$\pm 50$	A	
Power dissipation	$T_c=25^\circ\text{C}$	$P_D$	40	W
	$T_A=25^\circ\text{C}$	$P_D$	1.5	W
Channel temperature	$T_{ch}$	150	$^\circ\text{C}$	
Storage temperature	$T_{stg}$	-55 to +150	$^\circ\text{C}$	

\*  $PW \leq 10\ \mu\text{s}$ , duty cycle  $\leq 1\%$

## 2SJ602

## ■ Electrical Characteristics Ta = 25°C

Parameter	Symbol	Testconditons	Min	Typ	Max	Unit
Drain cut-off current	I <sub>DSS</sub>	V <sub>DS</sub> =-60V, V <sub>GS</sub> =0			-10	μ A
Gate leakage current	I <sub>GSS</sub>	V <sub>GS</sub> =±20V, V <sub>DS</sub> =0			±10	μ A
Gate to source cutoff voltage	V <sub>GS(off)</sub>	V <sub>DS</sub> =-10V, I <sub>D</sub> =-1mA	-1.5	-2.0	-2.5	V
Forward transfer admittance	Y <sub>fs</sub>	V <sub>DS</sub> =-10V, I <sub>D</sub> =-10A	8	16		S
Drain to source on-state resistance	R <sub>DS(on)</sub>	V <sub>GS</sub> =-10V, I <sub>D</sub> =-10A		59	73	m Ω
		V <sub>GS</sub> =-4.0V, I <sub>D</sub> =-10A		75	107	m Ω
Input capacitance	C <sub>iss</sub>	V <sub>DS</sub> =-10V, V <sub>GS</sub> =0, f=1MHZ		1300		pF
Output capacitance	C <sub>oss</sub>			240		pF
Reverse transfer capacitance	C <sub>rss</sub>			100		pF
Turn-on delay time	t <sub>d(on)</sub>			9		ns
Rise time	t <sub>r</sub>	V <sub>GS(on)</sub> =-30V, I <sub>D</sub> =-10A, V <sub>DD</sub> =-10V, R <sub>G</sub> =0 Ω		12		ns
Turn-off delay time	t <sub>d(off)</sub>			54		ns
Fall time	t <sub>f</sub>			15		ns
Total Gate Charge	Q <sub>G</sub>	I <sub>D</sub> = -20A		26		nC
Gate to Source Charge	Q <sub>GS</sub>	V <sub>DD</sub> = -48 V		5		nC
Gate to Drain Charge	Q <sub>GD</sub>	V <sub>GS</sub> = -10 V		7		nC
Body Diode Forward Voltage	V <sub>F(S-D)</sub>	I <sub>F</sub> = -20A, V <sub>GS</sub> = 0 V		1.0		V
Reverse Recovery Time	t <sub>rr</sub>	I <sub>F</sub> = -20 A, V <sub>GS</sub> = 0 V		50		ns
Reverse Recovery Charge	Q <sub>rr</sub>	di/dt = 100 A / μ s		110		nC