

SMD Type MOSFET

Silicon N-Channel MOSFET
2SK2715

Features

- Low on-resistance.
- Fast switching speed.
- Wide SOA (safe operating area).
- Easily designed drive circuits.
- Easy to parallel.

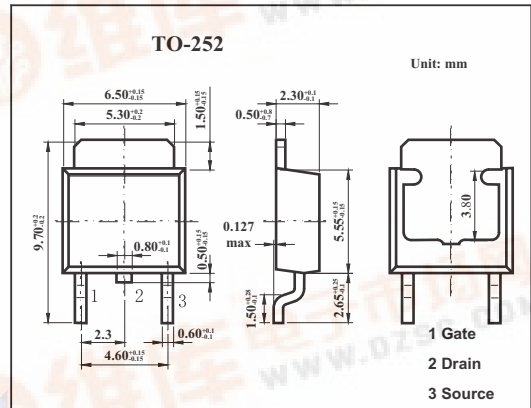

Absolute Maximum Ratings Ta = 25°C

Parameter	Symbol	Rating	Unit
Drain to source voltage	V _{DSS}	500	V
Gate to source voltage	V _{GSS}	±30	V
Drain current	I _D	2	A
	I _{DP} *	6	A
Power dissipation	P _D	20	W
Channel temperature	T _{ch}	150	°C
Storage temperature	T _{stg}	-55 to +150	°C

* PW ≤ 10 μs, Duty Cycle ≤ 1%

Electrical Characteristics Ta = 25°C

Parameter	Symbol	Test conditions	Min	Typ	Max	Unit	
Drain source breakdown voltage	V _{DSS}	I _D =1mA, V _{GS} =0V	500			V	
Drain cut-off current	I _{DSS}	V _{DS} =500V, V _{GS} =0			100	μA	
Gate leakage current	I _{GSS}	V _{GS} =±30V, V _{DS} =0			±100	nA	
Gate threshold voltage	V _{GS(th)}	V _{DS} =10V, I _D =1mA	2.0		4.0	V	
Forward transfer admittance	Y _{fs}	V _{DS} =10V, I _D =1A	0.6	1.5		S	
Drain to source on-state resistance	R _{DS(on)}	V _{GS} =10V, I _D =1A		3.0	4.0	Ω	
Input capacitance	C _{iss}	V _{DS} =10V, V _{GS} =0, f=1MHZ		280		pF	
Output capacitance	C _{oss}				58		pF
Reverse transfer capacitance	C _{rss}				23		pF
Turn-on delay time	t _{on}	I _D =1A, V _{GS(on)} =10V, R _G =10Ω, R _L =150Ω, V _{DD} =150V		10		ns	
Rise time	t _r				12		ns
Turn-off delay time	t _{off}				30		ns
Fall time	t _f				63		ns

