

SMD Type MOSFET

N-Channel Silicon MOSFET
2SK2869

Features

- Low on-resistance
 $R_{DS} = 0.033 \Omega$ typ.
- High speed switching
- 4V gate drive device can be driven from 5V source

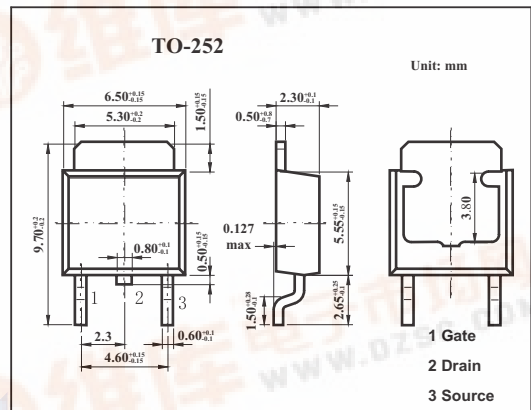
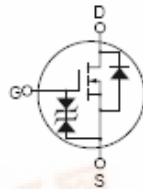

Absolute Maximum Ratings $T_a = 25^\circ C$

Parameter	Symbol	Rating	Unit
Drain to source voltage	V_{DSS}	60	V
Gate to source voltage	V_{GSS}	± 20	V
Drain current	I_D	20	A
	I_{dp}^*	80	A
Power dissipation	P_D	30	W
Channel temperature	T_{ch}	150	$^\circ C$
Storage temperature	T_{stg}	-55 to +150	$^\circ C$

* $PW \leq 10 \mu s, Duty Cycle \leq 1\%$

Electrical Characteristics $T_a = 25^\circ C$

Parameter	Symbol	Testconditions	Min	Typ	Max	Unit
Drain to source breakdown voltage	V_{DSS}	$I_D = 10mA, V_{GS} = 0$	60			V
Drain cut-off current	I_{DSS}	$V_{DS} = 60V, V_{GS} = 0$			10	μA
Gate leakage current	I_{GSS}	$V_{GS} = \pm 16V, V_{DS} = 0$			± 10	μA
Gate to source cutoff voltage	$V_{GS(off)}$	$V_{DS} = 10V, I_D = 1mA$	1.5		2.5	V
Forward transfer admittance	$ Y_{fs} $	$V_{DS} = 10V, I_D = 10A$	10	16		S
Drain to source on-state resistance	$R_{DS(on)}$	$V_{GS} = 10V, I_D = 10A$		0.033	0.045	Ω
		$V_{GS} = 4V, I_D = 10A$		0.055	0.07	Ω
Input capacitance	C_{iss}	$I_D = 10A, V_{GS(on)} = 10V, R_L = 3\Omega$		740		pF
Output capacitance	C_{oss}			380		pF
Reverse transfer capacitance	C_{rss}			140		pF
Turn-on delay time	t_{on}			10		ns
Rise time	t_r			110		ns
Turn-off delay time	t_{off}			105		ns
Fall time	t_f			120		ns

