

SMD Type MOSFET

Silicon N-Channel Power F-MOSFET
2SK3025

Features

- Avalanche energy capacity guaranteed
- High-speed switching
- Low ON-resistance
- No secondary breakdown
- Low-voltage drive
- High electrostatic breakdown voltage

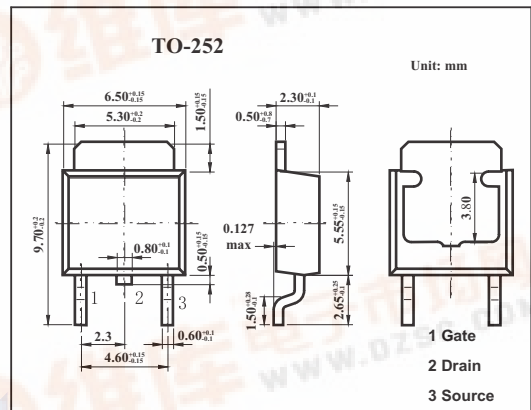
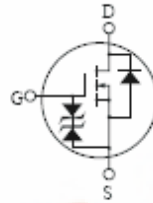

Absolute Maximum Ratings Ta = 25°C

Parameter	Symbol	Rating	Unit
Drain to source voltage	V _{DSS}	60	V
Gate to source voltage	V _{GSS}	±20	V
Drain current	I _D	±30	A
	I _{DP} *	±60	A
Power dissipation	P _D	T _C =25°C	20
		T _A =25°C	1
Channel temperature	T _{ch}	150	°C
Storage temperature	T _{stg}	-55 to +150	°C

* PW ≤ 10 μs, Duty Cycle ≤ 1%

Electrical Characteristics Ta = 25°C

Parameter	Symbol	Test conditions	Min	Typ	Max	Unit	
Drain to source breakdown voltage	V _{DSS}	I _D =1mA, V _{GS} =0	60			V	
Drain cut-off current	I _{DSS}	V _{DS} =50V, V _{GS} =0			10	μA	
Gate leakage current	I _{GSS}	V _{GS} =±20V, V _{DS} =0			±10	μA	
Gate threshold voltage	V _{th}	V _{DS} =10V, I _D =1mA	1		2.5	V	
Forward transfer admittance	Y _{fs}	V _{DS} =10V, I _D =15A	9	18		S	
Drain to source on-state resistance	R _{DS(on)}	V _{GS} =10V, I _D =15A		25	40	mΩ	
		V _{GS} =4V, I _D =15A		35	55	mΩ	
Input capacitance	C _{iss}	V _{DS} =10V, V _{GS} =0, f=1MHZ		1200		pF	
Output capacitance	C _{oss}			400		pF	
Reverse transfer capacitance	C _{rss}			200		pF	
Turn-on delay time	t _{on}				10		ns
Rise time	t _r				20		ns
Turn-off delay time	t _{off}	I _D =15A, V _{GS(on)} =10V, R _L =2Ω, V _{DD} =30V		350		ns	
				140		ns	

