



Bulletin 700-HA

- 10 A Contact Rating
- DPDT, 3PDT
- Pin Style Terminals
- Standard ON/OFF Flag Indicator
- Clear Cover for Easy Visual Inspection
- Optional Push-to-test and Manual Override
- Optional LED
- Optional Socket Mounted Surge Suppressor Module
- Optional Multi-Function Timing Module
- Type HAB—Bifurcated Contacts
- Type HAX—Gold Bifurcated Contacts

TABLE OF CONTENTS

| Description | Page | Description | Page |
|-------------------------|------|------------------------------|------|
| Product Selection | 43 | Timing Charts | 51 |
| Accessories | 46 | Approximate Dimensions | 52 |
| Specifications | 49 | | |

Description

The Bulletin 700-HA General Purpose Relays have pin-style terminals and are available in 2-pole (DPDT) or 3-pole (3PDT). They feature a standard ON/OFF flag indicator, and can be ordered with an optional push-to-test operator, a LED, and bifurcated or gold bifurcated contacts. Coils are available in a wide range of AC and DC voltages. Contacts are rated up to 10 A.

Conformity to Standards:

EN 60947-4-1
 EN 60947-5-1
 IEC 947
 CSA 22.2
 UL 508
 NEMA/EE MAC compliant
 ICS-2 compliant

Approvals:

cURus Recognized, File E3125
 Guide NLDX 2
 cULus Listed, with Allen-Bradley socket
 CE Marked (per EU Low Voltage
 Directive 73/23 EEC 93/68 EEC)
 ABS (American Bureau of Shipping),
 File 00-GE195140-PDA
 RINA listed

Your order must include:

- Cat. No. of the plug-in relay plus suffixes of selection options.
- Cat. No. of socket required.
- If required, Cat. No. of any accessories.

Third Party Approval:

IMQ listed

Bulletin 700-HA Tube Base Relay with PIN Terminals (Single Contact) —
Mechanical ON/OFF Indicator included ❶

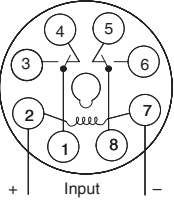
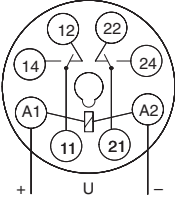
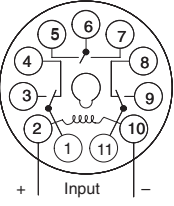
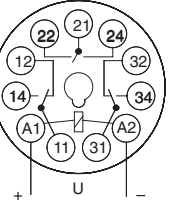
| | Description | Contact Rating | Wiring Diagrams | | Coil Voltage | Cat. No. ②③④ | Factory-Stocked Item | | | | | | |
|---|--|----------------|---|--|--------------|-----------------|----------------------|-----------|------------------------|--|--|--|--|
| | | | U.S./Canada | International | | | ⑦ | ⑧ | | | | | |
|  | DPDT 2-Pole 2 Form C Single AgNi Contact | 10 A B300 |  |  | 6V AC | 700-HA32A06 | | | | | | | |
| | | | | | 12V AC | 700-HA32A12 | ✓ | | | | | | |
| | | | | | 24V AC | 700-HA32A24 ⑤ | ✓ | | | | | | |
| | | | | | 120V AC | 700-HA32A1 ⑤ | ✓ | ✓ | | | | | |
| | | | | | 240V AC | 700-HA32A2 ⑤ | ✓ | | | | | | |
| | | | | | 277V AC | 700-HA32A27⑥ | ✓ | | | | | | |
| | | | | | 6V DC | 700-HA32Z06 | | | | | | | |
| | | | | | 12V DC | 700-HA32Z12 ⑤ | ✓ | | | | | | |
| | | | | | 24V DC | 700-HA32Z24 ⑤ | ✓ | | | | | | |
| | | | | | 36V DC | 700-HA32Z36 | | | | | | | |
| | | | | | 48V DC | 700-HA32Z48 | ✓ | | | | | | |
| | | | | | 110V DC | 700-HA32Z1 | ✓ | | | | | | |
| | | | | | 125V DC | 700-HA32Z01 | ✓ | | | | | | |
| | | | | | 140V DC | 700-HA32Z3 | | | | | | | |
| Sockets | | | 700-HN125 | 700-HN100 700-HN202 | | | | | | | | | |
| | 3PDT 3-Pole 3 Form C Single AgNi Contact | 10 A B300 |  |  | 6V AC | 700-HA33A06 | | | | | | | |
| | | | | | 12V AC | 700-HA33A12 | | | | | | | |
| | | | | | 24V AC | 700-HA33A24 ⑤ | ✓ | | | | | | |
| | | | | | 120V AC | 700-HA33A1 ⑤ | ✓ | ✓ | | | | | |
| | | | | | 240V AC | 700-HA33A2 | ✓ | | | | | | |
| | | | | | 6V DC | 700-HA33Z06 | | | | | | | |
| | | | | | 12V DC | 700-HA33Z12 | ✓ | | | | | | |
| | | | | | 24V DC | 700-HA33Z24 ⑤ | ✓ | | | | | | |
| | | | | | 48V DC | 700-HA33Z48 | | | | | | | |
| | | | | | 110V DC | 700-HA33Z1 | | | | | | | |
| | | | | | 125V DC | 700-HA33Z01 | ✓ | | | | | | |
| | | | | | 140V DC | 700-HA33Z3 | | | | | | | |
| | | | | | Sockets | | | 700-HN126 | 700-HN101 700-HN203 | | | | |

- ❶ For Time Module and Surge Suppressor Module, see page 47.
- ❷ LED Option: Add suffix (-4) to the selected Bulletin 700-HA Relay Cat. No., except for the 240V AC Units, add (-4L).
- ❸ Push-to-test, Manual Override, and LED Option: Add suffix (-3-4) to the selected Bulletin 700-HA Relay Cat. No., except for the 240V AC units, add (-3-4L).
- ❹ Push-to-test and Manual Override option: Add suffix (-3) to the selected Bulletin 700-HA relay.
- ❺ Bulk Package Option: Relay can be purchased at discounted prices in bulk quantities of 10. Add suffix (-99) to the selected relay catalog number.
- ❻ LED not available.
- ❼ Single pack
- ❽ Bulk pack

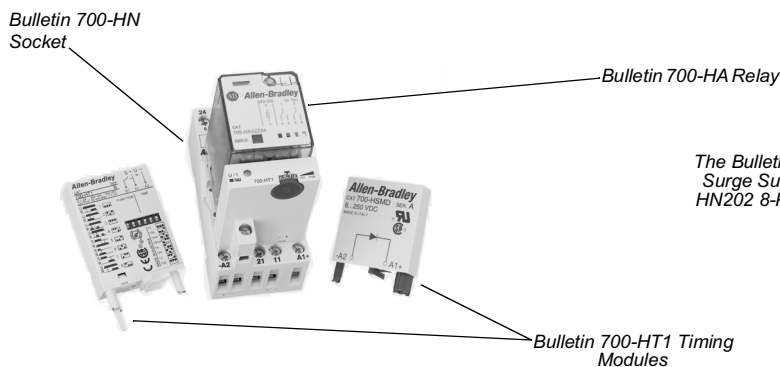

The Bulletin 700-HA Relays can be used together with Timing or Surge Suppressor Modules by plugging in to the Cat. No. 700-HN202 8-Pin Socket, or the Cat. No. 700-HN203 11-Pin Socket.

Bulletin 700-HA
General Purpose Relays
Product Selection, Continued

Bulletin 700-HAB Tube Base Relay with PIN Terminals (Bifurcated Contacts) —
Mechanical ON/OFF Indicator included ❶

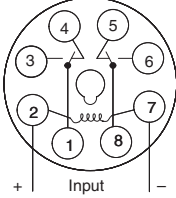
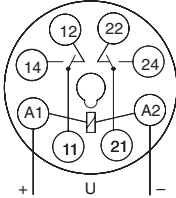
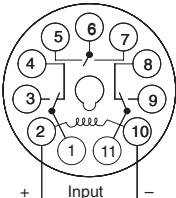
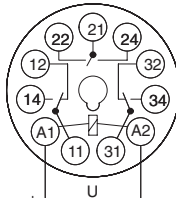
| | Description | Contact Rating | Wiring Diagrams | | Coil Voltage | Cat. No. ❷❸❹ | Factory-stocked Item ❺ | | | | |
|--|---|----------------|---|--|--------------|-----------------|---------------------------|------------------------|--|--|--|
| | | | U.S./Canada | International | | | | | | | |
|  | DPDT 2-Pole 2 Form C Bifurcated AgNi Contacts | 4 A |  |  | 6V AC | 700-HAB2A06 | | | | | |
| | | | | | 12V AC | 700-HAB2A12 | | | | | |
| | | | | | 24V AC | 700-HAB2A24 | | | | | |
| | | | | | 120V AC | 700-HAB2A1 | ✓ | | | | |
| | | | | | 240V AC | 700-HAB2A2 | | | | | |
| | | | | | 277V AC | 700-HAB2A27 ❻ | | | | | |
| | | | | | 6V DC | 700-HAB2Z06 | | | | | |
| | | | | | 12V DC | 700-HAB2Z12 | | | | | |
| | | | | | 24V DC | 700-HAB2Z24 | ✓ | | | | |
| | | | | | 36V DC | 700-HAB2Z36 | | | | | |
| | | | | | 48V DC | 700-HAB2Z48 | | | | | |
| | | | | | 110V DC | 700-HAB2Z1 | | | | | |
| | | | | | 125V DC | 700-HAB2Z01 | | | | | |
| | | | | | 140V DC | 700-HAB2Z3 | | | | | |
| Sockets | | 700-HN125 | 700-HN100 700-HN202 | | | | | | | | |
| | 3PDT 3-Pole 3 Form C Bifurcated AgNi Contacts | 4 A |  |  | 6V AC | 700-HAB3A06 | | | | | |
| | | | | | 12V AC | 700-HAB3A12 | | | | | |
| | | | | | 24V AC | 700-HAB3A24 | | | | | |
| | | | | | 120V AC | 700-HAB3A1 | ✓ | | | | |
| | | | | | 240V AC | 700-HAB3A2 | | | | | |
| | | | | | 6V DC | 700-HAB3Z06 | | | | | |
| | | | | | 12V DC | 700-HAB3Z12 | | | | | |
| | | | | | 24V DC | 700-HAB3Z24 | ✓ | | | | |
| | | | | | 48V DC | 700-HAB3Z48 | | | | | |
| | | | | | 110V DC | 700-HAB3Z1 | | | | | |
| | | | | | 125V DC | 700-HAB3Z01 | | | | | |
| | | | | | 140V DC | 700-HAB3Z3 | | | | | |
| | | | | | Sockets | | 700-HN126 | 700-HN101 700-HN203 | | | |

❶ For Time Module and Surge Suppressor Module, see page 47.

❷ LED Option: Add suffix (-4) to the selected Bulletin 700-HAB Relay Cat. No., except for the 240V AC Units, add (-4L).

❸ Push-to-test, Manual Override & Pilot Light Option: Add suffix (-3 -4) to the selected Bulletin 700-HAB Relay Cat. No., except for the 240V AC units, add (-3 -4L).

❹ Push-to-test and Manual Override option: Add suffix (-3) to the selected Bulletin 700-HA relay.

❺ Single Pack





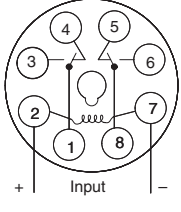
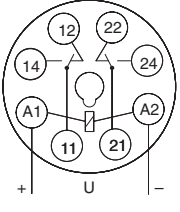
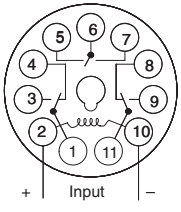
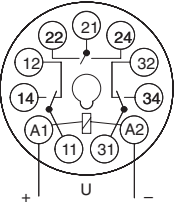

❻ LED not available.













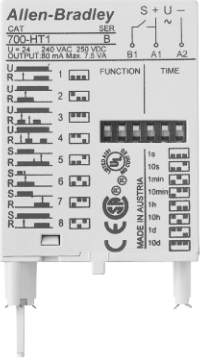























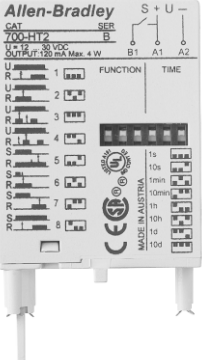













**Bulletin 700-HAX Tube Base Relay with PIN Terminals (Bifurcated Contacts with Gold Overlay) —
 Mechanical ON/OFF Indicator Included ❶**

| | Description | Contact Rating | Wiring Diagrams | | Coil Voltage | Cat. No. ❷❸❹ | Factory-stocked Item ❺ | | | | |
|--|---|----------------|---|--|--------------|-----------------|---------------------------|------------------------|--|--|--|
| | | | U.S./Canada | International | | | | | | | |
|  | DPDT 2-Pole 2 Form C Bifurcated AgNi Contacts with Gold Overlay Sockets | 4 A |  |  | 6V AC | 700-HAX2A06 | | | | | |
| | | | | | 12V AC | 700-HAX2A12 | | | | | |
| | | | | | 24V AC | 700-HAX2A24 | | | | | |
| | | | | | 120V AC | 700-HAX2A1 | ✓ | | | | |
| | | | | | 240V AC | 700-HAX2A2 | | | | | |
| | | | | | 277V AC | 700-HAX2A27❻ | | | | | |
| | | | | | 6V DC | 700-HAX2Z06 | | | | | |
| | | | | | 12V DC | 700-HAX2Z12 | | | | | |
| | | | | | 24V DC | 700-HAX2Z24 | ✓ | | | | |
| | | | | | 36V DC | 700-HAX2Z36 | | | | | |
| | | | | | 48V DC | 700-HAX2Z48 | | | | | |
| | | | | | 110V DC | 700-HAX2Z1 | | | | | |
| | | | | | 125V DC | 700-HAX2Z01 | | | | | |
| | | | | | 140V DC | 700-HAX2Z3 | | | | | |
| Sockets | | 700-HN125 | 700-HN100 700-HN202 | | | | | | | | |
| | 3PDT 3-Pole 3 Form C Bifurcated AgNi Contacts with Gold Overlay | 4 A |  |  | 6V AC | 700-HAX3A06 | | | | | |
| | | | | | 12V AC | 700-HAX3A12 | | | | | |
| | | | | | 24V AC | 700-HAX3A24 | | | | | |
| | | | | | 120V AC | 700-HAX3A1 | ✓ | | | | |
| | | | | | 240V AC | 700-HAX3A2 | | | | | |
| | | | | | 6V DC | 700-HAX3Z06 | | | | | |
| | | | | | 12V DC | 700-HAX3Z12 | | | | | |
| | | | | | 24V DC | 700-HAX3Z24 | ✓ | | | | |
| | | | | | 48V DC | 700-HAX3Z48 | | | | | |
| | | | | | 110V DC | 700-HAX3Z1 | | | | | |
| | | | | | 125V DC | 700-HAX3Z01 | | | | | |
| | | | | | 140V DC | 700-HAX3Z3 | | | | | |
| | | | | | Sockets | | 700-HN126 | 700-HN101 700-HN203 | | | |

- ❶ For Time Module and Surge Suppressor Module, see page 47.
- ❷ LED Option: Add suffix (-4) to the selected Bulletin 700-HAX Relay Cat. No., except for the 240V AC Units, add (-4L).
- ❸ Push-to-test and LED Option: Add suffix (-3-4) to the selected Bulletin 700-HAX Relay Cat. No., except for the 240V AC units, add (-3-4L).
- ❹ Push-to-test and Manual Override option: Add suffix (-3) to the selected Bulletin 700-HA relay.
- ❺ LED not available.
- ❻ Single pack

Bulletin 700-HA
General Purpose Relays
Accessories

| | Description | Pkg. Qty. | Cat. No. | Factory-stocked Item |
|---|---|-----------|-----------|----------------------|
|  <p>Cat. No. 700-HN100</p> | <p>Screw Terminal Tube Base Sockets – Panel or DIN Rail Mounting. Guarded Terminal Construction 8-pin for use with DPDT Bulletin 700-HA relays, -HX digital timing relays, -HT (ON-Delay) and -HRM, -HRC and -HV (Repeat Cycle) timing relays. Order must be for 10 sockets or multiples of 10.</p> | 10 | 700-HN100 | ✓ |
|  <p>Cat. No. 700-HN125</p> | <p>Screw Terminal Tube Base Sockets – Panel or DIN Rail Mounting Open Style Construction 8-pin for use with DPDT Bulletin 700-HA relays, -HT (ON-Delay) and -HRM, -HRC and -HV (Repeat Cycle) timing relays. Order must be for 10 sockets or multiples of 10. No retainer clip required.</p> | 10 | 700-HN125 | ✓ |
|  <p>Cat. No. 700-HN101</p> | <p>Screw Terminal Tube Base Sockets – Panel or DIN Rail Mounting. Guarded Terminal Construction 11-pin for use with 3PDT Bulletin 700-HA relays, -HR and -HT (OFF-Delay) timing relays. Order must be for 10 sockets or multiples of 10.</p> | 10 | 700-HN101 | ✓ |
|  <p>Cat. No. 700-HN126</p> | <p>Screw Terminal Tube Base Sockets – Panel or DIN Rail Mounting. Guarded Terminal Construction 11-pin for use with 3PDT Bulletin 700-HA relays, -HR and -HT (OFF-Delay) timing relays. Order must be for 10 sockets or multiples of 10.</p> | 10 | 700-HN126 | ✓ |
|  <p>Cat. No. 700-HN203</p> | <p>8-Pin Socket – Can Be Used With or Without Timing Attachment or Surge Suppressor Screw Terminal Tube Base Sockets – panel or DIN Rail mounting. Guarded terminal construction. Used with DPDT Bulletin 700-HA relays. Order must be for 10 sockets or multiples of 10.</p> | 10 | 700-HN202 | ✓ |
| | <p>11-Pin Socket – Can Be Used With or Without Timing Attachment or Surge Suppressor Screw Terminal Tube Base Sockets – panel or DIN Rail mounting. Guarded terminal construction. Used with 3PDT Bulletin 700-HA relays. Order must be for 10 sockets or multiples of 10.</p> | 10 | 700-HN203 | ✓ |
|  <p>Cat. No. 199-DR1</p> | <p>DIN Rail Mounting Pack Standard 35 x 7.5 mm DIN Rail, 1 meter long, 10 rails per package. Order must be for 10 rails or multiples of 10.</p> | 10 | 199-DR1 | ✓ |

| | Description | Pkg. Qty. | Cat. No. | Factory-stocked Item | | | | | | | | | | | | | | | | | | | | | | | | |
|---|---|---|----------|---|----|------|---|----|--------|---|----|---------|---|----|--------|---|----|----------|---|----|------------------|---|----|---------------------|---|---|---------|---|
|  <p>Cat. No. 700-HSV1</p> | MOV Suppressor Module ① Voltage Range: 24V AC 24...30V DC Order must be for 20 modules or multiples of 20. | 20 | 700-HSV1 | ✓ | | | | | | | | | | | | | | | | | | | | | | | | |
| | MOV Suppressor Module ① Voltage Range: 220...240V AC 220...300V DC Order must be for 20 modules or multiples of 20. | 20 | 700-HSV2 | ✓ | | | | | | | | | | | | | | | | | | | | | | | | |
| | MOV Suppressor Module ① Voltage Range: 110...120V AC 110...150V DC Order must be for 20 modules or multiples of 20. | 20 | 700-HSV3 | ✓ | | | | | | | | | | | | | | | | | | | | | | | | |
|  <p>Cat. No. 700-HSMD</p> | Diode Surge Suppressor ① Voltage Range: 6...250V DC Order must be for 20 modules or multiples of 20. | 20 | 700-HSMD | ✓ | | | | | | | | | | | | | | | | | | | | | | | | |
|  <p>Cat. No. 700-HT1</p> | Multi-Function Multi-Range Time Module ① Voltage range 24...240V AC 50/60 Hz and 24...250V DC, with a voltage variation of 85...110%. Repeat accuracy of <0.5%. Reset time 150 ms. Refer to page 50 for Specifications. Eight (8) Timing Modes Eight (8) Timing Ranges: <table style="margin-left: 20px;"> <tr><td>1.</td><td>1 s</td><td></td></tr> <tr><td>2.</td><td>10 s</td><td></td></tr> <tr><td>3.</td><td>1 min.</td><td></td></tr> <tr><td>4.</td><td>10 min.</td><td></td></tr> <tr><td>5.</td><td>1 hour</td><td></td></tr> <tr><td>6.</td><td>10 hours</td><td></td></tr> <tr><td>7.</td><td>1 day (24 hours)</td><td></td></tr> <tr><td>8.</td><td>10 days (240 hours)</td><td></td></tr> </table> LED Indicator: 1. Steady Green (G) for power on, flashing during timing. | 1. | 1 s |  | 2. | 10 s |  | 3. | 1 min. |  | 4. | 10 min. |  | 5. | 1 hour |  | 6. | 10 hours |  | 7. | 1 day (24 hours) |  | 8. | 10 days (240 hours) |  | 1 | 700-HT1 | ✓ |
| 1. | 1 s |  | | | | | | | | | | | | | | | | | | | | | | | | | | |
| 2. | 10 s |  | | | | | | | | | | | | | | | | | | | | | | | | | | |
| 3. | 1 min. |  | | | | | | | | | | | | | | | | | | | | | | | | | | |
| 4. | 10 min. |  | | | | | | | | | | | | | | | | | | | | | | | | | | |
| 5. | 1 hour |  | | | | | | | | | | | | | | | | | | | | | | | | | | |
| 6. | 10 hours |  | | | | | | | | | | | | | | | | | | | | | | | | | | |
| 7. | 1 day (24 hours) |  | | | | | | | | | | | | | | | | | | | | | | | | | | |
| 8. | 10 days (240 hours) |  | | | | | | | | | | | | | | | | | | | | | | | | | | |
|  <p>Cat. No. 700-HT2</p> | Multi-Function Multi-Range Time Module ① Voltage range 12...30V DC, with a voltage variation of 90...110%. Repeat accuracy of <0.5%. Reset time 150 ms. Refer to page 50 for Specifications. Eight (8) Timing Modes (See page 51 for further details.) Eight (8) Timing Ranges: <table style="margin-left: 20px;"> <tr><td>1.</td><td>1 s</td><td></td></tr> <tr><td>2.</td><td>10 s</td><td></td></tr> <tr><td>3.</td><td>1 min.</td><td></td></tr> <tr><td>4.</td><td>10 min.</td><td></td></tr> <tr><td>5.</td><td>1 hour</td><td></td></tr> <tr><td>6.</td><td>10 hours</td><td></td></tr> <tr><td>7.</td><td>1 day (24 hours)</td><td></td></tr> <tr><td>8.</td><td>10 days (240 hours)</td><td></td></tr> </table> LED Indicator: 1. Steady Green (G) for power on, flashing during timing | 1. | 1 s |  | 2. | 10 s |  | 3. | 1 min. |  | 4. | 10 min. |  | 5. | 1 hour |  | 6. | 10 hours |  | 7. | 1 day (24 hours) |  | 8. | 10 days (240 hours) |  | 1 | 700-HT2 | |
| 1. | 1 s |  | | | | | | | | | | | | | | | | | | | | | | | | | | |
| 2. | 10 s |  | | | | | | | | | | | | | | | | | | | | | | | | | | |
| 3. | 1 min. |  | | | | | | | | | | | | | | | | | | | | | | | | | | |
| 4. | 10 min. |  | | | | | | | | | | | | | | | | | | | | | | | | | | |
| 5. | 1 hour |  | | | | | | | | | | | | | | | | | | | | | | | | | | |
| 6. | 10 hours |  | | | | | | | | | | | | | | | | | | | | | | | | | | |
| 7. | 1 day (24 hours) |  | | | | | | | | | | | | | | | | | | | | | | | | | | |
| 8. | 10 days (240 hours) |  | | | | | | | | | | | | | | | | | | | | | | | | | | |

① Suppressors and Time Modules easily plug into sockets (Cat. Nos. 700-HN202 and 700-HN203). For use with Bulletin 700-HA relays.

ATTENTION: Cat. No. 700-HT1 Series A is wired with switch “S” connected to “A2”, but 700-HT1 Series B is wired with switch “S” connected to “A1”. The Time Modules must be wired correctly. Check the front of the Time Modules for the correct wiring diagrams.

Bulletin 700-HA
General Purpose Relays
Accessories, Continued

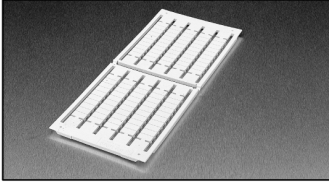
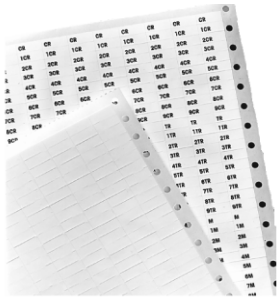
| | Description | Pkg. Qty. | Cat. No. | Factory-stocked Item |
|--|--|-----------|--|----------------------|
|  <p>Sample Retainer Clips</p> | Retainer Clip for Cat. Nos. 700-HN100, -HN101, -HN200, -HN201, -HN202, and -HN203 Sockets with Bulletin 700-HA Relays ❶ Secures relay in socket. Order must be for 10 clips or multiples of 10. | 10 | 700-HN157 | ✓ |
|  <p>Snap-in markers</p> | Relay Identification Snap-in Markers ❷ Snap-in markers fit on top of Bulletin 700-HA relay covers. The following are blank cards. Squares slip into molded slot on top of Bulletin 700-HA or 700-HB relay cover. | 100 | 1492-SM5X12 1492-SM6X9 1492-SM6X12 1492-SM8X9 1492-SM8X12 1492-MP-Blank | ❷ |
|  | Pre-printed identification tags – contains 10 sheets of pre-printed and blank tags. Each sheet contains 13 sets of the markings CR...9CR, TR...9TR, M...9M, F, R, 1S, and 117 blank tags. Tags are peel-off with sticky backing for easy placement on relays. | 10 | 700-N40 | |
| | Blank identification tags – contains 10 sheets of blank identification tags for customer specialized printing. Each sheet contains 546 blank tags. Tags are peel-off with sticky backing for easy placement on relays. | 10 | 700-N41 | |

❶ See Bulletin 700-HA Relay, Socket, and Retainer Clip Reference Chart

❷ Refer to terminal block marking systems within the Industrial Control Catalog, publication A114

❸ For pre-printed marker cards, turn to the following 1492 sections: 1492-SM5X12_, 1492-SM6X9_, 1492-SM8X9_, 1492-SM8X12_, 1492-MP_

| Relay Type | Socket | Retainer Clip |
|------------|-----------|----------------|
| 700-HA32 | 700-HN100 | 700-HN157 |
| 700-HAB2 | 700-HN125 | Not Required ❹ |
| 700-HAX2 | 700-HN202 | 700-HN157 |
| | 700-HN200 | 700-HN157 |
| 700-HA33 | 700-HN201 | 700-HN157 |
| 700-HAB3 | 700-HN101 | 700-HN157 |
| 700-HAX3 | 700-HN126 | Not Required ❹ |
| | 700-HN203 | 700-HN157 |

❹ Design of these sockets holds the relays securely and does not require retainer clips.

Bulletin 700-HA
General Purpose Relays
Specifications

| | | Cat. No. 700-HA... | | |
|---|--------------|--|--------------|-----------|
| Electrical Ratings | | | | |
| Pilot Duty Rating ② | | NEMA B300 | | |
| Rated Thermal Current (I_{th}) | | HA = 10 A – 120V, 240V HAB/HAX = 6 A – 120V, 240V | | |
| Rated Insulation Voltage (U_i) | | 250V IEC – 300V UL/CSA | | |
| Contacts | Inductive | Make | Break | Hp |
| | 120V AC | ▶ ◀ | ◀ ▶ | 0.33 |
| | 240V AC | 30 A | 3 A | 1 |
| | DC | 15 A | 1.5 A | |
| Min. Low Energy Permissible Load | | HA = 10V, 50 mA HAB= 6V, 30 mA HAX = 6V, 1 mA | | |
| Permissible Coil Voltage Variation | | 85...110% of Nominal Voltage at 50 Hz 85...110% of Nominal Voltage at 60 Hz 80...110% of Nominal Voltage at DC | | |
| Coil Consumption ±10% | AC Coils | 50 Hz | 60 Hz | |
| | Inrush | 3.3 VA | 2.85 VA | |
| | Sealed | 2.2 VA | 1.9 VA | |
| | DC Coils | 1.3 W | | |
| Max. Allowable Leakage | | 25% of VA | | |
| | | 10% of W | | |
| Design Specification/Test Requirements | | | | |
| Electrical | | | | |
| Dielectric Withstand Voltage | | 2000V | | |
| Pole-to-Pole | | 2000V | | |
| Contact to Coil | | 2000V | | |
| Contact to Frame | | 2000V | | |
| Electrical Life (Operating) | | 100,000 min. | | |
| Mechanical | | | | |
| Degree of Protection (Open Type) IEC 529 | | IP 40 | | |
| Mechanical Life Operations (AC/DC) | | > 20 x 10 ⁶ / 50 x 10 ⁶ | | |
| Switching Frequency Operations | | 3600/HR | | |
| Coil Voltages | | See Product Selection | | |
| Operating Time | Max. Pickup | 10 ms | | |
| | Max. Dropout | 10 ms | | |
| Maximum Operating Rate | | 4 Ops/s | | |
| Vibration | Endurance | 5 G | | |
| | Operational | 2.5 G | | |
| Shock | Endurance | 50 G | | |
| | Operational | 9 G | | |
| Environmental | | | | |
| Temperature | Operating | AC/DC | -40...+70°C | |
| | Storage | AC/DC | -40...+100°C | |
| Altitude | | 2000 m (6560 ft) | | |
| Construction | | | | |
| Insulating Material | | Molded High Dielectric Material | | |
| Enclosure | | Transparent Dust Cover | | |
| Contact Material | | 700-HA: 10 A– AgNi 700-HAB: 4 A–Bifurcated AgNi 700-HAX: 4 A–Bifurcated/Gold Plating AgNi | | |
| Terminal Markings on Socket | | In accordance with EN50 0005 | | |
| Sockets | | 8-Pin Socket — 700-HN100, -HN125, -HN202 11-Pin Socket — 700-HN101, -HN126, -HN203 | | |
| Certifications | | CE, cULus listed, IMQ, RINA, ABS | | |

① Performance Data – See page Important-2, Industrial Controls Catalog.

② NEMA Rating Chart is on page 29.

Bulletin 700-HA
General Purpose Relays
Specifications, Continued ❶

700-HA Relay Performance Graphs

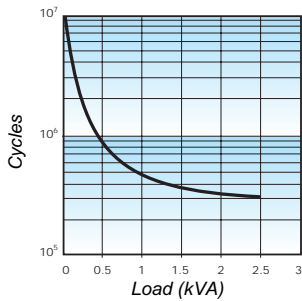

Contact life vs. AC1 load at 1,800 cycles/h

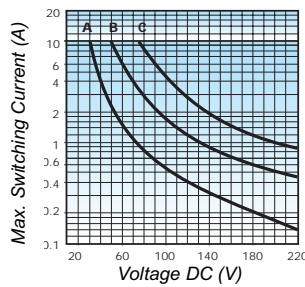

Breaking capacity for DC1 load at 1800 cycles/h
A= load applied to 1 contact
B= load applied to 2 contacts in series
C= load applied to three contacts in series

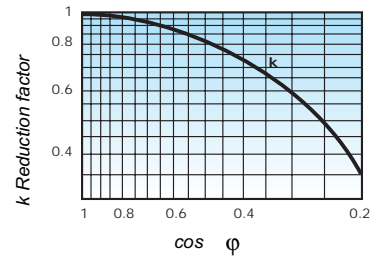

Load reduction factor vs. $\cos \phi$

| | | Time Module Cat. No. 700-HT1 | Time Module Cat. No. 700-HT2 |
|---|--------------------------------|---|---|
| Electrical Ratings | | | |
| Operating Voltage Range | | 24...240V AC at 50/60 Hz 24...250V DC | 12...30V DC |
| Power Consumption | | 24V AC/DC 70 mW 240V AC/DC 700 mW | 12V DC 40 mW 30V DC 100 mW |
| Maximum Output Current | | 80 mA (2 W at 24V DC) | 120 mA (2 W at 24V DC) |
| Maximum Output Voltage | | 265V AC, 275V DC | 33V DC |
| Maximum Output Power | | 7.5 VA (30 mA at 240V AC) | 4 W |
| Mechanical | | | |
| Degree of Protection of Input (B1) Terminal | | IP 20 (Guarded Terminal) | |
| Input Terminal Wire Range | | 2 x 1.5 mm ² (2 # 16 AWG...1 # 20 AWG) | |
| Input Terminal Torque Range | | 0.45...0.8 Nm (4...7 lb-in.) | |
| LED Indicator | | Steady when Power On and Flashing during Timing Period | |
| Repeat Accuracy ❷ | | <0.5% or 5 ms | |
| Timing Change | Voltage Effect Temp. Effect | ≤0.001%/V ≤0.01%/°C | ≤0.001%/V ≤0.01%/°C |
| Reset Time | | Power Reset: 150 ms Signal Reset: 50 ms AC, 30 ms DC | Power Reset: 150 ms Signal Reset: 10 ms DC |
| Selectable Timing Ranges | | 3 DIP Switches, 8 Ranges (set from 10...100% of range): 1 s, 10 s, 1 min., 10 min., 1 hr., 10 hr., 24 hr., 240 hr. | |
| Selectable Timing Modes | | 3 DIP Switches, 8 Modes: Power ON–Delay Single Shot – Power On Repeat Cycle – Starting with OFF–Delay Repeat Cycle – Starting with ON–Delay Signal OFF–Delay Single Shot – Signal is a Pulse Single Shot – Signal Off Signal ON–Delay | |
| Thumbwheel Scale Accuracy | | ≤5% of Time Range | |
| Environmental | | | |
| Temperature | Operating Storage | –25...+55°C (–13...+131°F) –55...+85°C (–67...+185°F) | |
| Altitude | | 2000 m (6560 ft) | |
| Construction | | | |
| Enclosure | | Gray Plastic Housing | |
| Mounting with Socket Only | | 8- or 11-Pin Socket with Module Plug | |
| Sockets | | 700-HN202 (8-Pin with Plug) 700-HN203 (11-Pin with Plug) | |
| Certifications | | CE, UL listed, CSA | |

❶ Performance Data - See page Important-2, publication A113.

❷ At constant voltage and temperature.

Timing Charts, Cat. Nos. 700-HT1 and 700-HT2 Multi-Function Time Module (t = Time Range 0.10 s...240 h)
Cat. Nos. 700-HT1 and -HT2 Timing Modes, Time Description, Timing Charts, and DIP Switch Selections

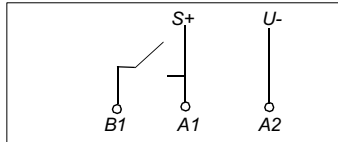

Terms:
U is Power Input (Steady Green LED)
R is Relay Output
S Control, **+A1** Socket, **B1** Timer
t is the resulting Time Delay (Flashing Green LED)

1. Power On-Delay

When the input voltage U is applied, the timing delay t begins. The relay contacts R change state after the time delay is complete. The contacts will return to their shelf state when the power U is removed. The terminal $B1$ is not used in this mode.

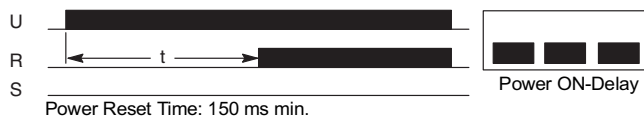

2. Single Shot — Power On

When the input voltage U is applied, the relay contacts R change state immediately and the timing cycle begins. When the time delay t is complete, the contacts return to shelf state. When the input voltage U is removed, the contacts return to their shelf state. The terminal $B1$ is not used in this mode.

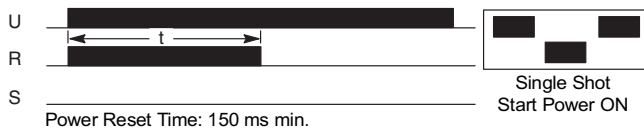

3. Repeat Cycle — Starting with Relay Energized

When the input voltage U is applied, the relay contacts R change state immediately and time delay t begins. When the time delay t is complete, the contacts return to their shelf state for time delay t . This cycle will repeat until the input voltage U is removed. The terminal $B1$ is not used in this mode.

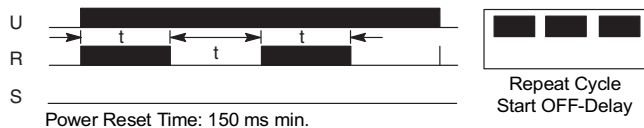

4. Repeat Cycle — Starting with On-Delay

When the input voltage U is applied, the time delay t begins. When the time delay t is complete, the relay contacts R change state for the time delay t . This cycle will repeat until the input voltage U is removed. The terminal $B1$ is not used in this mode.

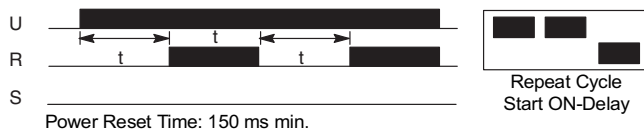

5. Signal Off-Delay

The input voltage U must be applied continuously. When the control S (wired at $B1$) is energized, the relay contacts R change state. When the control S is de-energized, the delay t begins. When delay t is complete, the contacts R return to their shelf state. If signal S is energized before the time delay t is complete, then the Time Module is reset, the delay begins again, and the relay contacts remain in their energized state. If the input voltage U is removed, the relay contacts R return to their shelf state.

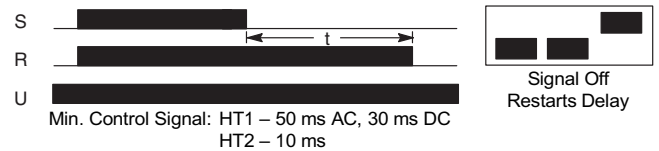

6. Single Shot — Signal Is a Pulse

The input U must be applied continuously. When the Control S (wired to $B1$ terminal) is energized, the relay contacts R change state and the time delay t begins. When the time delay t is completed, the contacts return to their shelf state. If signal S is de-energized before time t is completed, contacts R still stay in their changed state. The input signal S has control again when delay is completed or power reset. If the input voltage U is removed, the relay contacts R return to their shelf state.

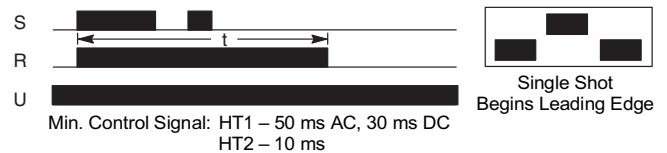

7. Single Shot — Signal Off

The input voltage U must be applied continuously. When the control S (wired at $B1$) is energized and then de-energized, the relay contacts R change state for the time delay t . If the control S is pulsed during the time period t , the relay contacts R will not be affected. If the input power is removed, the relay contacts R return to their shelf state.

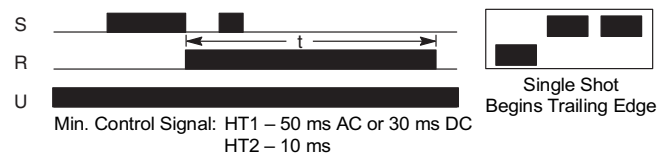

8. On Delay — Pulse Controlled

The input voltage U must be applied continuously. When the control S (wired at $B1$) is energized, the time delay t begins. When the time delay t is complete, the relay contacts R change state and remain energized until the control S is de-energized. If the input power U is removed the relay contacts R return to their shelf state.

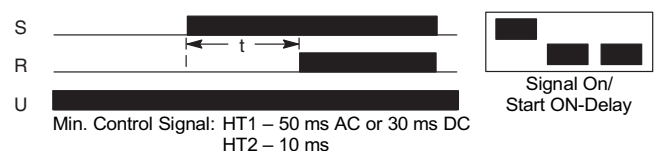

Bulletin 700-HA
General Purpose Relays
Approximate Dimensions

Dimensions are shown in millimeters (inches). Dimensions are not intended to be used for manufacturing purposes.

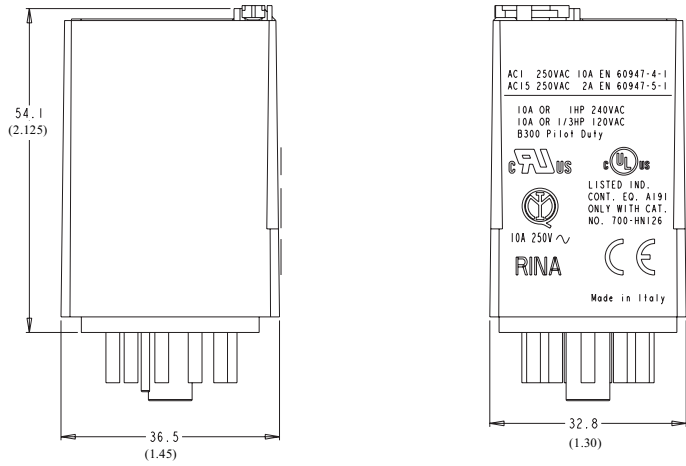

Bulletin 700-HA Relay

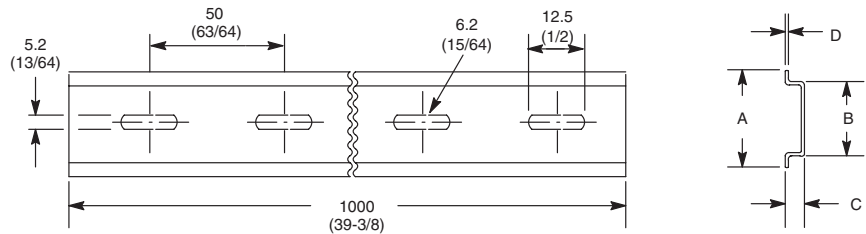

Cat. No. 199-DR1 DIN Mounting Rail Series B
 Cat. No. 199-DR4 DIN Mounting Rail Series B Has No Mounting Holes

| Cat. No. | A | B | C | D | Approx. Shipping Wt. |
|----------|---------------|----------------|----------------|----------------|---------------------------------|
| 199-DR1 | 35 (1-3/8) | 27 (1-1/16) | 7.5 (19/64) | 1.02 (1/64) | 1.85 kg (4.07 lbs.) (10/pkg) |
| 199-DR4 | 35 (1-3/8) | 27 (1-1/16) | 15 (19/32) | 2.3 (3/32) | 3.68 kg (8 lbs.) (5/pkg) |

Bulletin 700-HA
General Purpose Relays
Approximate Dimensions, Continued

Dimensions are shown in millimeters (inches). Dimensions are not intended to be used for manufacturing purposes.

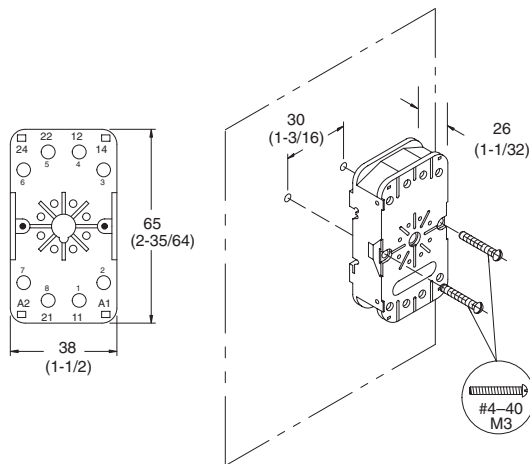

Cat. No. 700-HN100

Panel Mounting

Wire Size: $2 \times 2.5 \text{ mm}^2$
 Single Wire – Up to #12 AWG
 Double Wire – $2 \times 2.5 \text{ mm}^2$ (#2–14 AWG...#2–20 AWG)
 (Either Solid or Stranded)
 Strip Length: 9 mm (3/8") – Torque: 0.8 Nm (7 lb.-in.)

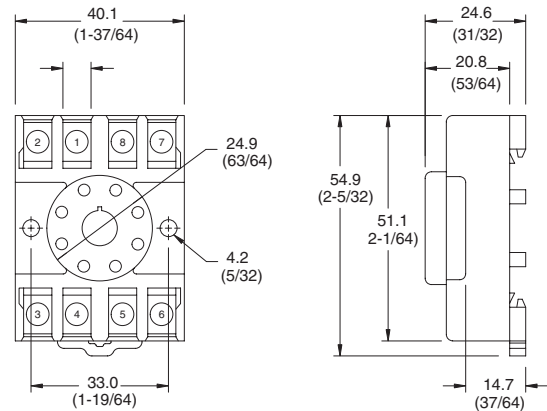

Cat. No. 700-HN125

Wire Size: $2 \times 2.5 \text{ mm}^2$
 Single Wire – Up to 12 AWG
 Double Wire – $2 \times 2.5 \text{ mm}^2$ (#2–#4 AWG...#2–20 AWG)
 (Either Solid or Stranded)
 Strip Length: 9 mm (3/8") – Torque: 0.8 Nm (7 lb.-in.)

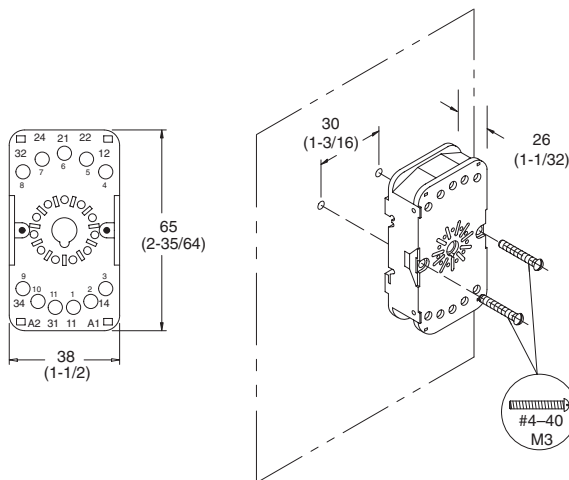

Cat. No. 700-HN101

Panel Mounting

Wire Size: $2 \times 2.5 \text{ mm}^2$
 Single Wire – Up to #12 AWG
 Double Wire – $2 \times 2.5 \text{ mm}^2$ (#2–14 AWG...#2–20 AWG)
 (Either Solid or Stranded)
 Strip Length: 9 mm (3/8 in.) – Torque: 0.8 Nm (7 lb.-in.)

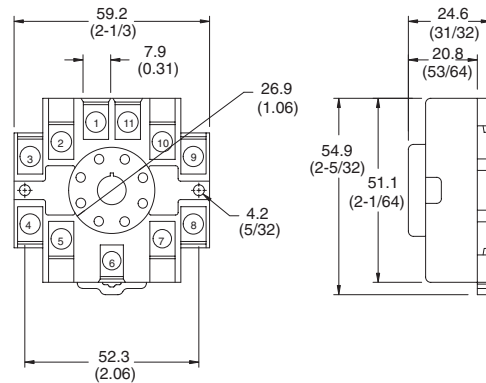

Cat. No. 700-HN126

Wire Size: $2 \times 2.5 \text{ mm}^2$
 Single Wire – Up to #12 AWG
 Double Wire – $2 \times 2.5 \text{ mm}^2$ (#2–14 AWG...#2–20 AWG)
 (Either Solid or Stranded)
 Strip Length: 9 mm (3/8 in.) – Torque: 0.8 Nm (7 lb.-in.)

• Cat. No. 199-FSM Surge Suppressors fit on the coil terminals. See page 195.

