

SMD Type MOSFET

P-Channel MOS FET For High-Speed Switching 2SJ181S

■ Features

- Low on-resistance
- High speed switching
- Low drive current
- No secondary breakdown
- Suitable for switching regulator and DC-DC converter

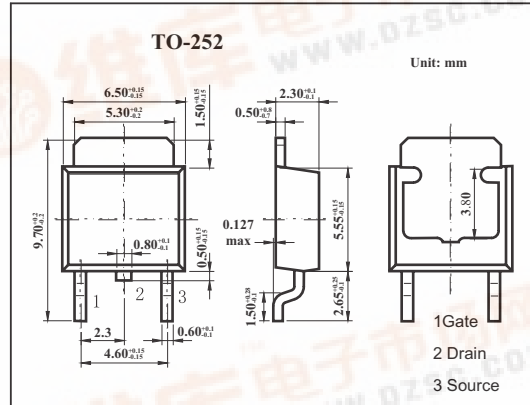

■ Absolute Maximum Ratings Ta = 25°C

Parameter	Symbol	Rating	Unit
Drain to source voltage	V _{DSS}	-600	V
Gate to source voltage	V _{GSS}	± 15	V
Drain current	I _{D(DS)}	-0.5	A
Drain peak current *	I _{D(pulse)}	-1	A
Channel dissipation (Tc=25°C)	P _{ch}	20	W
Channel temperature	T _{ch}	150	°C
Storage temperature	T _{stg}	-55 to +150	°C

* PW ≤ 10 μs, duty cycle ≤ 1%

2SJ181S

■ Electrical Characteristics Ta = 25°C

Parameter	Symbol	Testconditions	Min	Typ	Max	Unit
Drain to source breakdown voltage	V _{DSS}	I _D = -10 mA, V _{GS} = 0	-600			V
Gate to source breakdown voltage	V _{GSS}	I _G = ±100 μA, V _{DS} = 0	±15			V
Gate to source leak current	I _{GSS}	V _{GS} = ±12 V, V _{DS} = 0			±10	μA
Zero gate voltage drain current	I _{BSS}	V _{DS} = -500 V, V _{GS} = 0			-100	μA
Gate to source cutoff voltage	V _{GS(off)}	I _D = -1 mA, V _{DS} = -10 V	-2		-4	V
Static Drain to source on state resistance	R _{DS(on)}	I _D = -0.3 A, V _{GS} = -10 V		15	25	Ω
Forward transfer admittance	y _{fs}	I _D = -0.3 A, V _{DS} = -20 V	0.3	0.45		S
Input capacitance	C _{iss}	V _{DS} = -10 V, V _{GS} = 0,		220		pF
Output capacitance	C _{oss}	f = 1 MHz		55		pF
Reverse transfer capacitance	C _{rss}			13		pF
Turn-on delay time	t _{d(on)}	I _D = -0.3 A, V _{GS} = -10 V,		7		ns
Rise time	t _r	R _L = 100 Ω		20		ns
Turn-off delay time	t _{d(off)}			35		ns
Fall time	t _f			35		ns
Body to drain diode forward voltage	V _{DF}	I _F = -0.5 A, V _{GS} = 0		-0.85		V
Body to drain diode reverse recovery time	t _{rr}	I _F = -0.5 A, V _{GS} = 0, diF/dt = 50 A/μs		230		ns