

SMD Type MOSFET

MOS Field Effect Transistor
2SK3479

Features

- Super low on-state resistance:
 $R_{DS(on)1} = 11\text{ m}\Omega\text{ MAX. (}V_{GS} = 10\text{ V, }I_D = 42\text{ A)}$
 $R_{DS(on)2} = 13\text{ m}\Omega\text{ MAX. (}V_{GS} = 4.5\text{ V, }I_D = 42\text{ A)}$
- Low C_{iss} : $C_{iss} = 11000\text{ pF TYP.}$
- Built-in gate protection diode

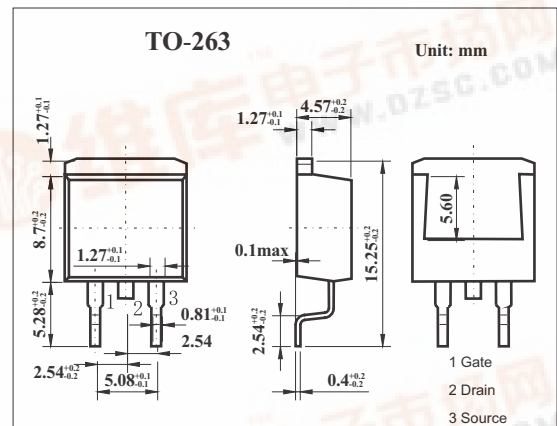

Absolute Maximum Ratings $T_a = 25^\circ\text{C}$

Parameter	Symbol	Rating	Unit
Drain to source voltage	V_{DS}	100	V
Gate to source voltage	V_{GS}	± 20	V
Drain current	I_D	± 83	A
	I_{dp}^*	± 332	A
Power dissipation	P_D	$T_c=25^\circ\text{C}$	125
		$T_a=25^\circ\text{C}$	1.5
Channel temperature	T_{ch}	150	$^\circ\text{C}$
Storage temperature	T_{stg}	-55 to +150	$^\circ\text{C}$

* $PW \leq 10\ \mu\text{s}$, Duty Cycle $\leq 1\%$

Electrical Characteristics $T_a = 25^\circ\text{C}$

Parameter	Symbol	Test conditions	Min	Typ	Max	Unit
Drain cut-off current	I_{DSS}	$V_{DS}=100\text{V, }V_{GS}=0$			10	μA
Gate leakage current	I_{GSS}	$V_{GS}=\pm 20\text{V, }V_{DS}=0$			± 10	μA
Gate cutoff voltage	$V_{GS(off)}$	$V_{DS}=10\text{V, }I_D=1\text{mA}$	1.5		2.5	V
Forward transfer admittance	$ Y_{fs} $	$V_{DS}=10\text{V, }I_D=42\text{A}$	37	74		S
Drain to source on-state resistance	$R_{DS(on)1}$	$V_{GS}=10\text{V, }I_D=42\text{A}$		8.8	11	$\text{m}\Omega$
	$R_{DS(on)2}$	$V_{GS}=4.5\text{V, }I_D=42\text{A}$		10	13	$\text{m}\Omega$
Input capacitance	C_{iss}	$V_{DS}=10\text{V, }V_{GS}=0, f=1\text{MHz}$		11000		pF
Output capacitance	C_{oss}			1100		pF
Reverse transfer capacitance	C_{rss}			540		pF
Turn-on delay time	t_{on}				27	ns
Rise time	t_r	$I_D=42\text{A, }V_{GS(on)}=10\text{V, }R_G=0\ \Omega, V_{DD}=50\text{V}$		18		ns
Turn-off delay time	t_{off}			140		ns
Fall time	t_f			13		ns
Total Gate Charge	Q_G				210	
Gate to Source Charge	Q_{GS}	$I_D=83\text{A, }V_{DD}=80\text{V, }V_{GS}=10\text{V}$		26		nC
Gate to Drain Charge	Q_{GD}			60		nC

