

Silicon NPN Power Transistors

BUV21

DESCRIPTION

- With TO-3 package
- High DC current gain@ $I_C=12A$
- Fast switching times
- Low collector saturation voltage

APPLICATIONS

- Designed for high current,high speed and high power applications.

PINNING(see fig.2)

PIN	DESCRIPTION
1	Base
2	Emitter
3	Collector

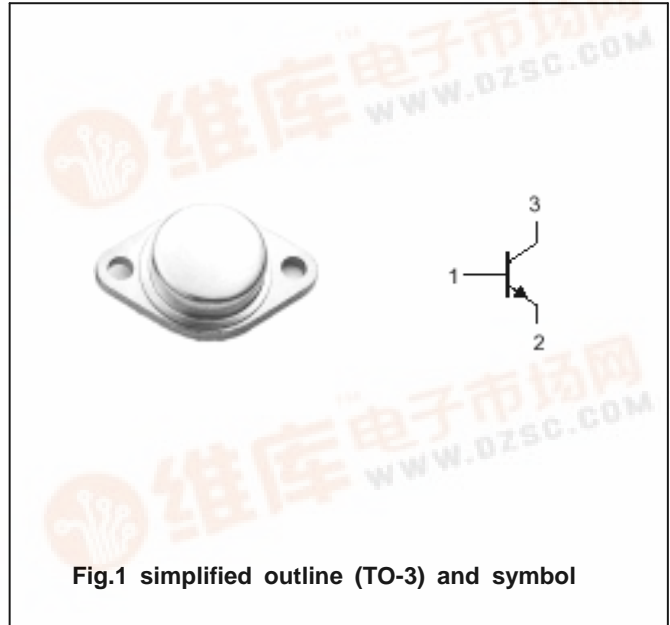

Fig.1 simplified outline (TO-3) and symbol

Absolute maximum ratings ( $T_c=25$  )

SYMBOL	PARAMETER	CONDITIONS	VALUE	UNIT
$V_{CBO}$	Collector-base voltage	Open emitter	250	V
$V_{CEO}$	Collector-emitter voltage	Open base	200	V
$V_{EBO}$	Emitter-base voltage	Open collector	7	V
$I_C$	Collector current		40	A
$I_{CM}$	Collector current-peak		50	A
$I_B$	Base current		8	A
$P_T$	Total power dissipation	$T_c=25$	150	W
$T_j$	Junction temperature		-65~200	
$T_{stg}$	Storage temperature		-65~200	

THERMAL CHARACTERISTICS

SYMBOL	PARAMETER	MAX	UNIT
$R_{th j-c}$	Thermal resistance junction to case	0.7	/W

## Silicon NPN Power Transistors

## BUV21

## CHARACTERISTICS

T<sub>j</sub>=25 unless otherwise specified

SYMBOL	PARAMETER	CONDITIONS	MIN	TYP.	MAX	UNIT
V <sub>CEO(SUS)</sub>	Collector-emitter sustaining voltage	I <sub>C</sub> =0.2A; I <sub>B</sub> =0; L=25mH	200			V
V <sub>(BR)EBO</sub>	Emitter-base breakdown voltage	I <sub>E</sub> =50mA; I <sub>C</sub> =0	7			V
V <sub>CEsat-1</sub>	Collector-emitter saturation voltage	I <sub>C</sub> =12 A; I <sub>B</sub> =1.2A			0.6	V
V <sub>CEsat-2</sub>	Collector-emitter saturation voltage	I <sub>C</sub> =25 A; I <sub>B</sub> =3A			1.5	V
V <sub>BEsat</sub>	Base-emitter saturation voltage	I <sub>C</sub> =25A; I <sub>B</sub> =3A			1.5	V
I <sub>CEX</sub>	Collector cut-off current	V <sub>CE</sub> =250V; V <sub>BE</sub> =-1.5V T <sub>C</sub> =125			3.0 12	mA
I <sub>CEO</sub>	Collector cut-off current	V <sub>CE</sub> =160V; I <sub>B</sub> =0			3.0	mA
I <sub>EBO</sub>	Emitter cut-off current	V <sub>EB</sub> =5V; I <sub>C</sub> =0			1.0	mA
h <sub>FE-1</sub>	DC current gain	I <sub>C</sub> =12A ; V <sub>CE</sub> =2V		20	60	
h <sub>FE-2</sub>	DC current gain	I <sub>C</sub> =25A ; V <sub>CE</sub> =4V		10		
f <sub>T</sub>	Transition frequency	I <sub>C</sub> =2A ; V <sub>CE</sub> =15V; f=4MHz	8.0			MHz

## Switching times

t <sub>on</sub>	Turn-on time	I <sub>C</sub> =25A ; I <sub>B1</sub> =-I <sub>B2</sub> =3A V <sub>CC</sub> =100V ; R <sub>C</sub> =4			1.0	μs
t <sub>s</sub>	Storage time				1.8	μs
t <sub>f</sub>	Fall time				0.4	μs

Silicon NPN Power Transistors

BUV21

PACKAGE OUTLINE

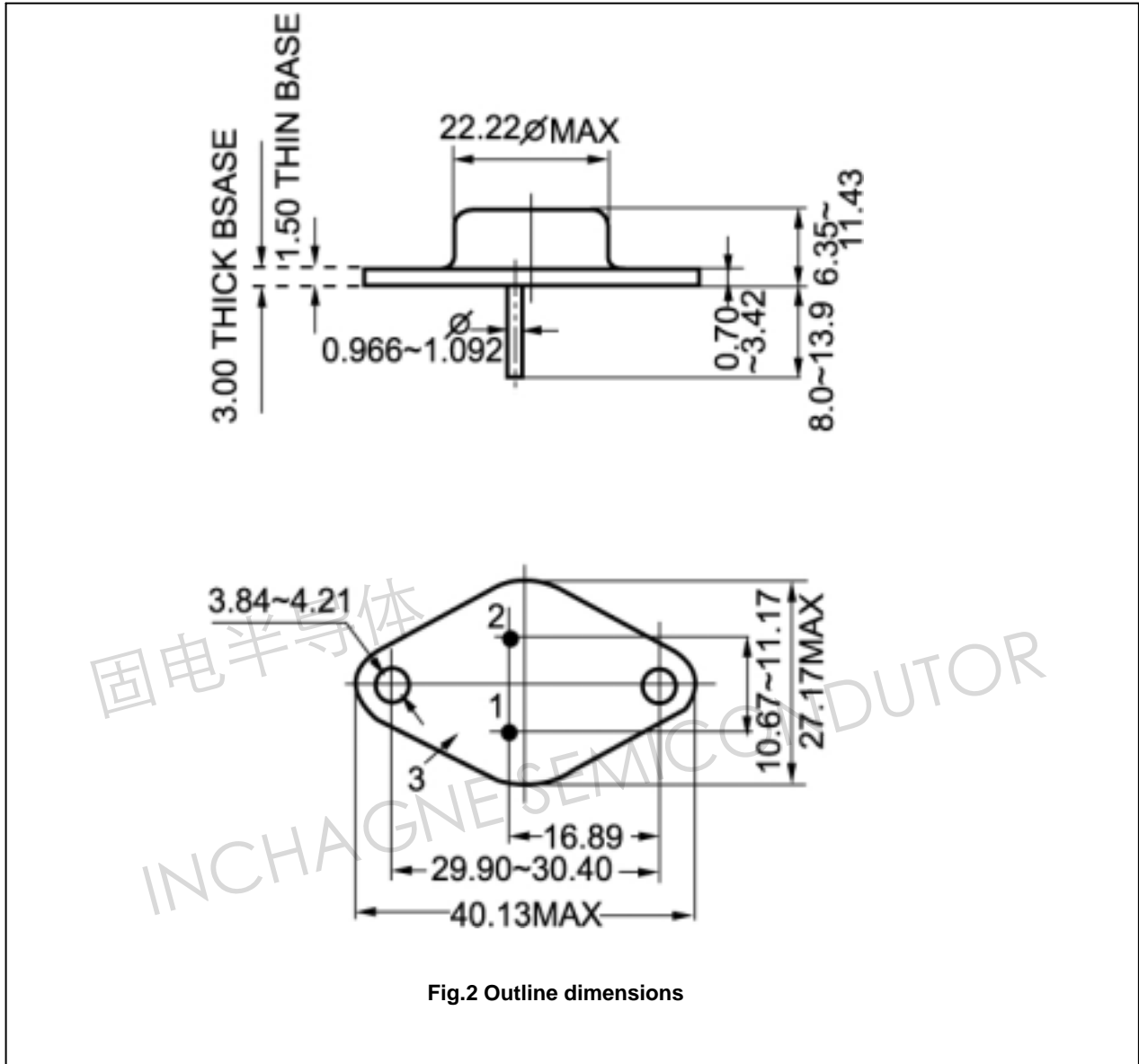

Fig.2 Outline dimensions