

**INCHANGE Semiconductor**

**isc Product Specification**

**isc Silicon NPN Power Transistor**

**2N5493**

**DESCRIPTION**

- Collector-Emitter Sustaining Voltage-  
:  $V_{CEO(SUS)} = 55V(\text{Min})$
- Low Saturation Voltage-  
:  $V_{CE(sat)} = 1V(\text{Max}) @ I_C = 2.5A$

**APPLICATIONS**

- Designed for a wide variety of medium-power switching and amplifier applications, such as series and shunt regulators and driver and output stages of high-fidelity amplifiers.

**ABSOLUTE MAXIMUM RATINGS( $T_a=25^\circ\text{C}$ )**

SYMBOL	PARAMETER	VALUE	UNIT
$V_{CBO}$	Collector-Base Voltage	75	V
$V_{CEV}$	Collector-Emitter Voltage $V_{BE} = -1.5V$	75	V
$V_{CER}$	Collector-Emitter Voltage $R_{BE} = 100 \Omega$	65	V
$V_{CEO}$	Collector-Emitter Voltage	55	V
$V_{EBO}$	Emitter-Base Voltage	5	V
$I_C$	Collector Current-Continuous	7	A
$I_B$	Base Current	3	A
$P_C$	Collector Power Dissipation @ $T_a=25^\circ\text{C}$	1.8	W
	Collector Power Dissipation @ $T_C=25^\circ\text{C}$	50	
$T_J$	Junction Temperature	150	$^\circ\text{C}$
$T_{stg}$	Storage Temperature Range	-65~150	$^\circ\text{C}$

**THERMAL CHARACTERISTICS**

SYMBOL	PARAMETER	MAX	UNIT
$R_{th\ j-c}$	Thermal Resistance, Junction to Case	2.5	$^\circ\text{C/W}$
$R_{th\ j-a}$	Thermal Resistance, Junction to Ambient	70	$^\circ\text{C/W}$

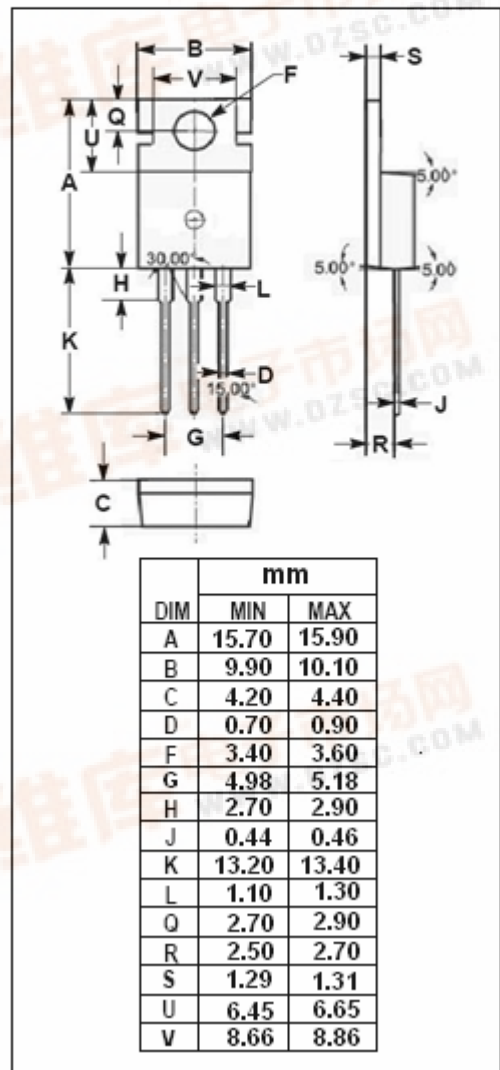
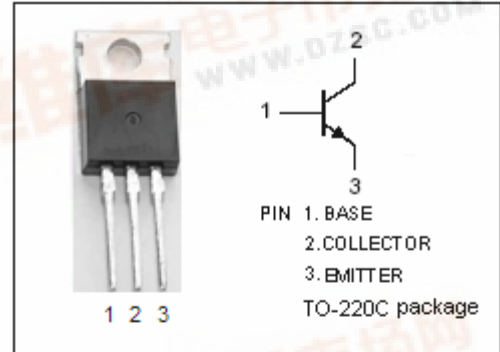

## isc Silicon NPN Power Transistor

2N5493

## ELECTRICAL CHARACTERISTICS

 $T_C=25^\circ\text{C}$  unless otherwise specified

SYMBOL	PARAMETER	CONDITIONS	MIN	MAX	UNIT
$V_{CEO(SUS)}$	Collector-Emitter Sustaining Voltage	$I_C=100\text{mA}; I_B=0$	55		V
$V_{CER(SUS)}$	Collector-Emitter Sustaining Voltage	$I_C=100\text{mA}; R_{BE}=100\ \Omega$	65		V
$V_{CEV(SUS)}$	Collector-Emitter Sustaining Voltage	$I_C=100\text{mA}; V_{BE}=-1.5\text{V}$	75		V
$V_{CE(sat)}$	Collector-Emitter Saturation Voltage	$I_C=2.5\text{A}; I_B=0.25\text{A}$		1.0	V
$V_{BE(on)}$	Base-Emitter On Voltage	$I_C=2.5\text{A}; V_{CE}=4\text{V}$		1.3	V
$I_{CEV}$	Collector Cutoff Current	$V_{CE}=70\text{V}; V_{BE}=-1.5\text{V}$ $V_{CE}=70\text{V}; V_{BE}=-1.5\text{V}; T_C=125^\circ\text{C}$		1.0 5.0	mA
$I_{CER}$	Collector Cutoff Current	$V_{CE}=55\text{V}; R_{BE}=100\ \Omega$ $V_{CE}=55\text{V}; R_{BE}=100\ \Omega; T_C=125^\circ\text{C}$		0.5 3.5	mA
$I_{EBO}$	Emitter Cutoff Current	$V_{EB}=5\text{V}; I_C=0$		1.0	mA
$h_{FE}$	DC Current Gain	$I_C=2.5\text{A}; V_{CE}=4\text{V}$	20	100	
$f_T$	Current-Gain—Bandwidth Product	$I_C=0.5\text{A}; V_{CE}=4\text{V}$	0.8		MHz

## Switching Times

$t_{on}$	Turn-On Time	$I_C=2.5\text{A}; I_{B1}=-I_{B2}=0.25\text{A}$		5	$\mu\text{s}$
$t_{off}$	Turn-Off Time			15	$\mu\text{s}$