

**Inchange Semiconductor**

**Product Specification**

**Silicon NPN Power Transistors**

**BU506D**

**DESCRIPTION**

- With TO-220C package
- High voltage
- Fast switching speed
- With integrated efficiency diode

**APPLICATIONS**

- Horizontal deflection circuits of colour TV receivers.
- Line-operated switch-mode applications.

**PINNING**

PIN	DESCRIPTION
1	Base
2	Collector;connected to mounting base
3	Emitter

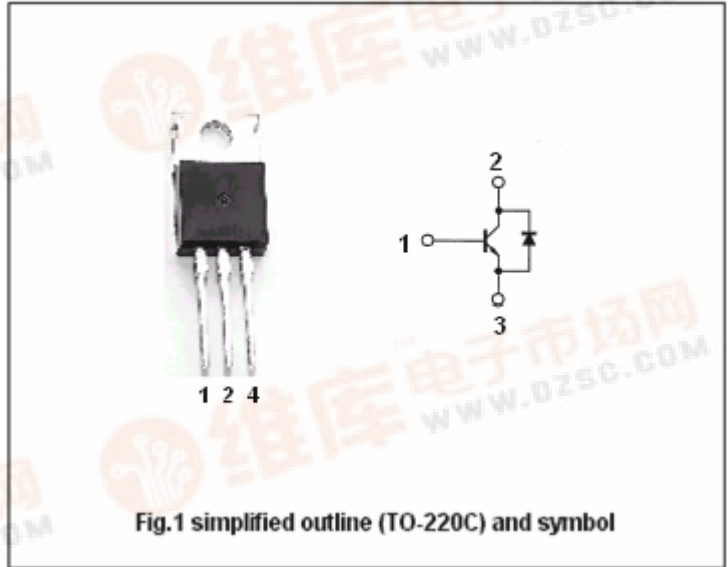

**Absolute maximum ratings (Ta=25 )**

SYMBOL	PARAMETER	CONDITIONS	VALUE	UNIT
V <sub>CBO</sub>	Collector-base voltage	Open emitter	1500	V
V <sub>CEO</sub>	Collector-emitter voltage	Open base	700	V
V <sub>EBO</sub>	Emitter-base voltage	Open collector	6	V
I <sub>C</sub>	Collector current (DC)		5	A
I <sub>CM</sub>	Collector current (Pulse)		8	A
I <sub>B</sub>	Base current		3	A
I <sub>BM</sub>	Base current(peak)		5	A
P <sub>C</sub>	Collector power dissipation	T <sub>C</sub> =25	100	W
T <sub>j</sub>	Junction temperature		150	
T <sub>stg</sub>	Storage temperature		-65-150	

## Silicon NPN Power Transistors

## BU506D

## CHARACTERISTICS

T<sub>j</sub>=25 unless otherwise specified

SYMBOL	PARAMETER	CONDITIONS	MIN	TYP.	MAX	UNIT
V <sub>CEO(SUS)</sub>	Collector-emitter sustaining voltage	I <sub>C</sub> =100mA; I <sub>B</sub> =0; L=25mH	700			V
V <sub>CEsat</sub>	Collector-emitter saturation voltage	I <sub>C</sub> =3A; I <sub>B</sub> =1.33A			1.0	V
V <sub>BEsat</sub>	Base-emitter saturation voltage	I <sub>C</sub> =3A; I <sub>B</sub> =1.33A			1.3	V
h <sub>FE</sub>	DC current gain	I <sub>C</sub> =0.1A; V <sub>CE</sub> =5V	6	13	30	
I <sub>CES</sub>	Collector cut-off current	V <sub>CE</sub> =rated; V <sub>BE</sub> =0 T <sub>C</sub> =125			0.5 1.0	mA
I <sub>EBO</sub>	Emitter cut-off current	V <sub>EB</sub> =6V; I <sub>C</sub> =0			200	mA
V <sub>F</sub>	Diode forward voltage	I <sub>F</sub> =3A;		1.5	2.2	V

## Switching times

t <sub>s</sub>	Storage time	I <sub>CM</sub> = 3 A; I <sub>B(end)</sub> = 1 A L <sub>B</sub> = 12 μ H		6.5		μ s
t <sub>f</sub>	Fall time			0.7		μ s

Silicon NPN Power Transistors

BU506D

PACKAGE OUTLINE

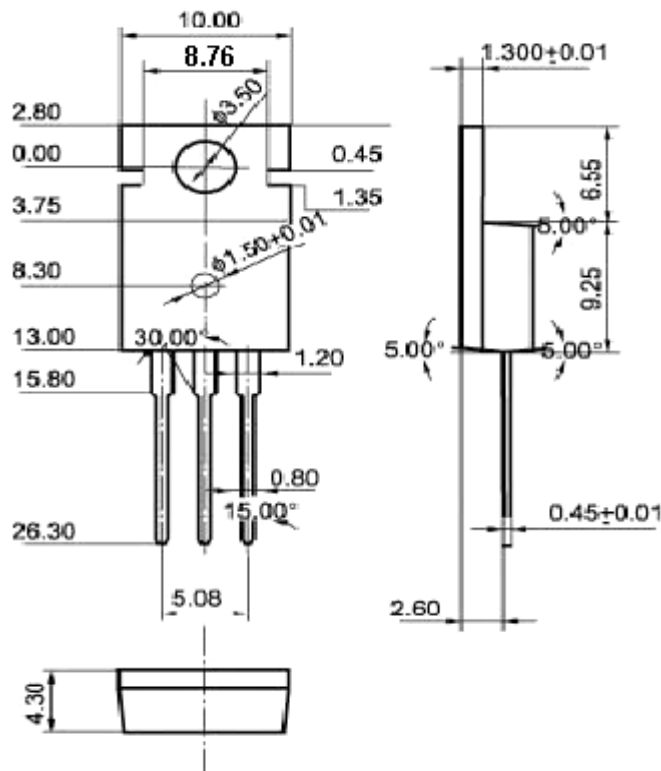

Fig.2 Outline dimensions (unindicated tolerance: ±0.10mm)