

INCHANGE Semiconductor

isc Product Specification

isc Silicon NPN Power Transistor

BU908

DESCRIPTION

- Collector-Emitter Sustaining Voltage-
: $V_{CEO(SUS)} = 700V$ (Min)
- High Power Dissipation-
: $P_D = 125W @ T_C = 25^\circ C$

APPLICATIONS

- Designed for use in color TV horizontal deflection circuits.

ABSOLUTE MAXIMUM RATINGS($T_a=25^\circ C$)

SYMBOL	PARAMETER	VALUE	UNIT
V_{CBO}	Collector- Base Voltage	1500	V
V_{CEO}	Collector-Emitter Voltage	700	V
V_{EBO}	Emitter-Base Voltage	7	V
I_C	Collector Current- Continuous	8	A
P_C	Collector Power Dissipation @ $T_C=25^\circ C$	125	W
T_J	Junction Temperature	150	$^\circ C$
T_{stg}	Storage Temperature Range	-65~150	$^\circ C$

THERMAL CHARACTERISTICS

SYMBOL	PARAMETER	MAX	UNIT
$R_{th\ j-c}$	Thermal Resistance, Junction to Case	1.0	$^\circ C/W$

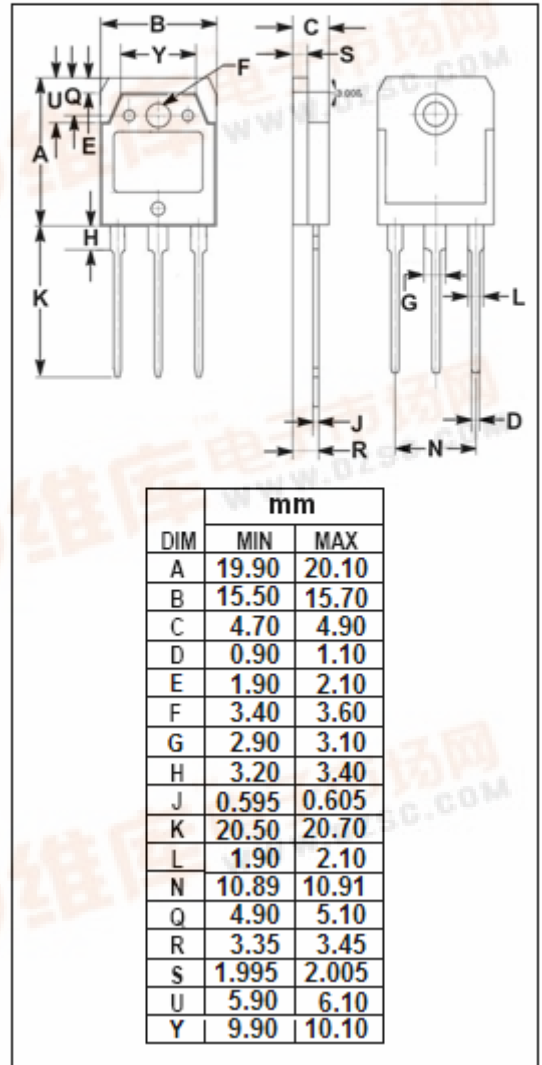
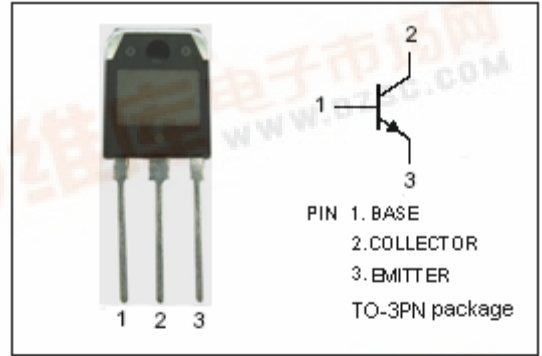

isc Silicon NPN Power Transistor

BU908

ELECTRICAL CHARACTERISTICS

 $T_C=25^{\circ}\text{C}$ unless otherwise specified

SYMBOL	PARAMETER	CONDITIONS	MIN	TYP.	MAX	UNIT
$V_{CE(SUS)}$	Collector-Emitter Sustaining Voltage	$I_C=100\text{mA}; I_B=0$	700			V
$V_{(BR)EBO}$	Emitter-Base Breakdown Voltage	$I_E=10\text{mA}; I_C=0$	7			V
$V_{CE(sat)}$	Collector-Emitter Saturation Voltage	$I_C=3.2\text{A}; I_B=0.8\text{A}$			2.0	V
$V_{BE(sat)}$	Base-Emitter Saturation Voltage	$I_C=3.2\text{A}; I_B=0.8\text{A}$			1.3	V
I_{CES}	Collector Cutoff Current	$V_{CE}=1500\text{V}; V_{BE}=0$ $V_{CE}=1500\text{V}; V_{BE}=0; T_C=125^{\circ}\text{C}$			0.1 2.0	mA
I_{EBO}	Emitter Cutoff Current	$V_{EB}=5.0\text{V}; I_C=0$			0.1	mA
h_{FE}	DC Current Gain	$I_C=1.5\text{A}; V_{CE}=5\text{V}$	8			
f_T	Current-Gain—Bandwidth Product	$I_C=0.1\text{A}; V_{CE}=10\text{V}$		7		MHz