

# Storage solution for PXA270 platform

## Features

- ProASIC®3 A3PE600-FG484 FPGA
- Multiple I/O interface connectors and receptacles
- Motherboard connectors
- Debug and expansion features
- Powered from motherboard or power jack
- CoreMP7 processor support

## Board Block Diagram

The FPGA interfaces directly to all connectors and devices (except USB and RS-232, which include Phy/driver chips). The IDE connectors and CompactFlash® connectors share pins, as do the CE-ATA connector and the second SDIO connector.

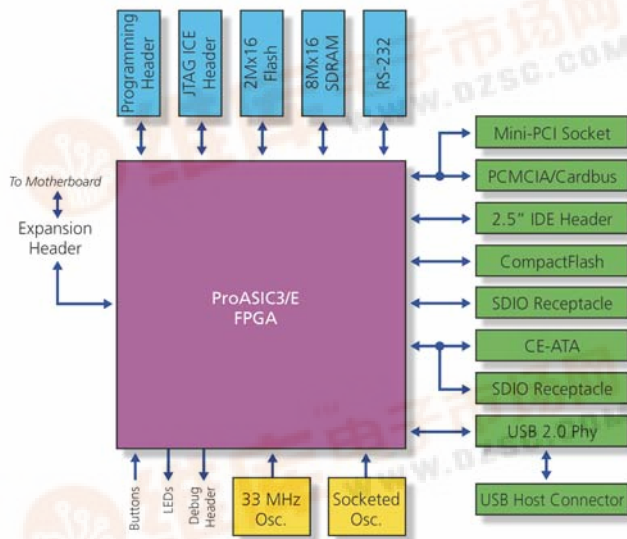

## System Block Diagram

The FPGA interfaces directly to the XScale processor, located on the motherboard.

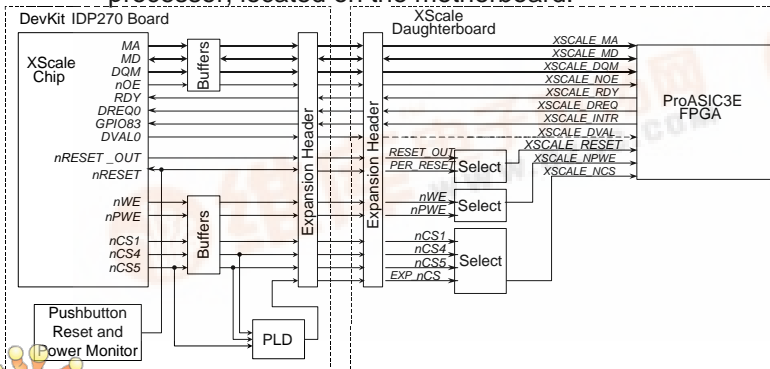

## Description

The storage solution demo board is designed to mount on the BSquare DevKit IDP270 Windows CE development board for demonstrating storage applications under Windows CE. Any of the featured interfaces can be demonstrated with the proper design programmed into the FPGA.

Any other motherboard may be used, utilizing the two motherboard connectors and a custom flex cable connector.

The storage solution board can also be used standalone if no processor is required, or if the processor is programmed into the FPGA. RS-232 and JTAG ICE connectors facilitate CPU programming and debug. Generous code and data spaces are available with 4 MB of bootable flash and 16 MB of SDRAM.

Additional user debug and demonstration features include a second oscillator for greater clock flexibility, 3 configuration DIP switches, 4 general-purpose LEDs, 1 general-purpose pushbutton, and 16 general-purpose I/Os.

For more information on the required motherboard,

## About Palmchip

Palmchip Corporation is a hardware and software design services company with a portfolio of system-on-a-chip (SoC) semiconductor intellectual property (IP). Palmchip couples design and integration services with pre-built and pre-verified platforms that dramatically reduce time to silicon and enable a practical design reuse environment. The company is headquartered in Santa Clara, California.

## About Actel

Actel Corporation is a supplier of innovative programmable logic solutions, including field-programmable gate arrays (FPGAs) based on antifuse and flash technologies, high-performance IP cores, software development tools, and design services targeted for the high-speed communications, application-specific integrated circuit (ASIC) replacement, and radiation-tolerant markets.

# Storage solution for PXA270 platform

## Board Top Side

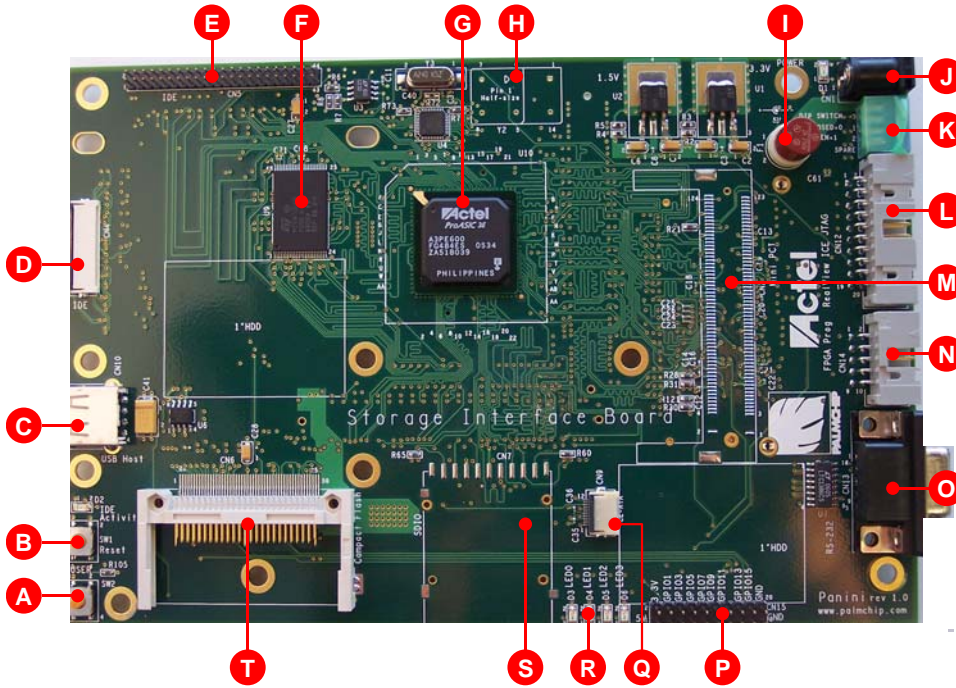

## Features

- A. User button
- B. Reset button
- C. USB 2.0 host connector
- D. FPC IDE connector
- E. 2.5" HDD IDE connector
- F. 2M x 16-bit NOR flash
- G. A3PE600-FG484 FPGA
- H. User oscillator socket
- I. 2 A fuse
- J. 5 V power jack
- K. 3 user DIP switches
- L. CoreM7 JTAG header
- M. Mini-PCI host connector
- N. FPGA programming header
- O. D-B9 RS-232
- P. 16-bit GPIO header
- Q. CE-ATA FPC connector
- R. 4 user LEDs
- S. SDIO receptacle
- T. CompactFlash receptacle
- U. PCMCIA/CardBus receptacle
- V. Secondary motherboard connector
- W. 33 MHz oscillator
- X. 2M x 16-bit SDRAM
- Y. Motherboard connector
- Z. SDIO receptacle

## Board Bottom Side

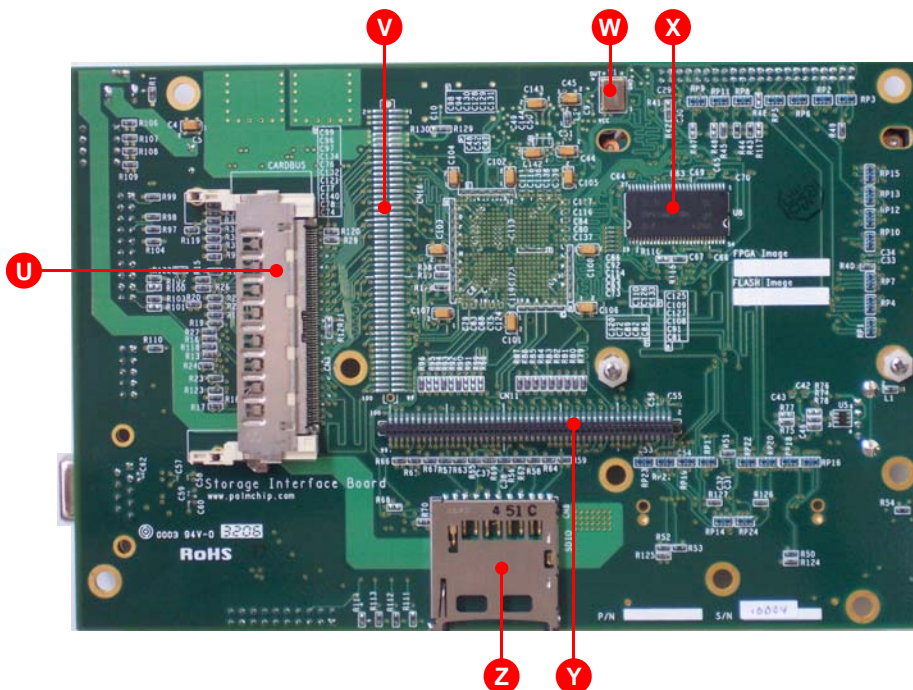

Contact Palmchip for IP designs available for this board.