

Inchange Semiconductor

Product Specification

Silicon NPN Power Transistors

2N5629 2N5630

DESCRIPTION

- With TO-3 package
- Complement to type 2N6029 2N6030

APPLICATIONS

- For high voltage and high power amplifier applications

PINNING

PIN	DESCRIPTION
1	Base
2	Emitter
3	Collector

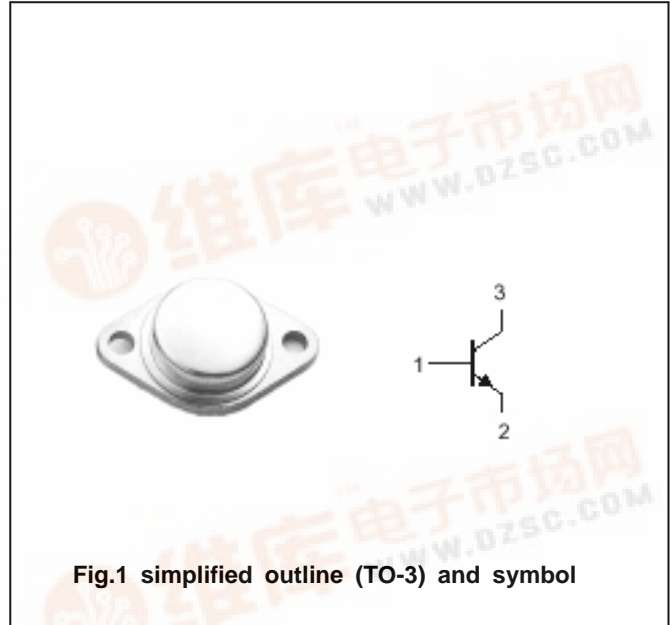

Absolute maximum ratings(Ta=)

SYMBOL	PARAMETER	CONDITIONS	VALUE	UNIT
V _{CBO}	Collector-base voltage	2N5629	100	V
		2N5630		
V _{CEO}	Collector-emitter voltage	2N5629	100	V
		2N5630		
V _{EBO}	Emitter-base voltage	Open collector	7	V
I _C	Collector current		16	A
I _{CM}	Collector current-peak		20	A
I _B	Base current		5.0	A
P _D	Total Power Dissipation	T _C =25	200	W
T _j	Junction temperature		200	
T _{stg}	Storage temperature		-65~200	

THERMAL CHARACTERISTICS

SYMBOL	PARAMETER	VALUE	UNIT
R _{th j-c}	Thermal resistance junction to case	0.875	/W

Silicon NPN Power Transistors

2N5629 2N5630

CHARACTERISTICS

T_j=25 unless otherwise specified

SYMBOL	PARAMETER		CONDITIONS	MIN	TYP.	MAX	UNIT
V _{CE0(SUS)}	Collector-emitter sustaining voltage	2N5629	I _C =0.2A ; I _B =0	100			V
		2N5630		120			
V _{CEsat-1}	Collector-emitter saturation voltage		I _C =10A; I _B =1A			1.0	V
V _{CEsat-2}	Collector-emitter saturation voltage		I _C =16A ; I _B =4A			2.0	V
V _{BEsat}	Base-emitter saturation voltage		I _C =10A; I _B =1A			1.8	V
V _{BE}	Base-emitter on voltage		I _C =8A ; V _{CE} =2V			1.5	V
I _{CBO}	Collector cut-off current		V _{CB} =ratedV _{CB0} ; I _E =0			1.0	mA
I _{CEO}	Collector cut-off current	2N5629	V _{CE} =50V; I _B =0			1.0	mA
		2N5630	V _{CE} =60V; I _B =0				
I _{CEV}	Collector cut-off current		V _{CE} =ratedV _{CB} ; V _{BE(off)} =1.5V T _C =150			1.0 5.0	mA
I _{EBO}	Emitter cut-off current		V _{EB} =7V; I _C =0			1.0	mA
h _{FE-1}	DC current gain	2N5629	I _C =8A ; V _{CE} =2V	25		100	
		2N5630		20		80	
h _{FE-2}	DC current gain		I _C =16A ; V _{CE} =2V	4			
C _{OB}	Output capacitance		I _E =0 ; V _{CB} =10V ; f=0.1MHz			500	pF
f _T	Transition frequency		I _C =1A ; V _{CE} =20V	1.0			MHz

Silicon NPN Power Transistors

2N5629 2N5630

PACKAGE OUTLINE

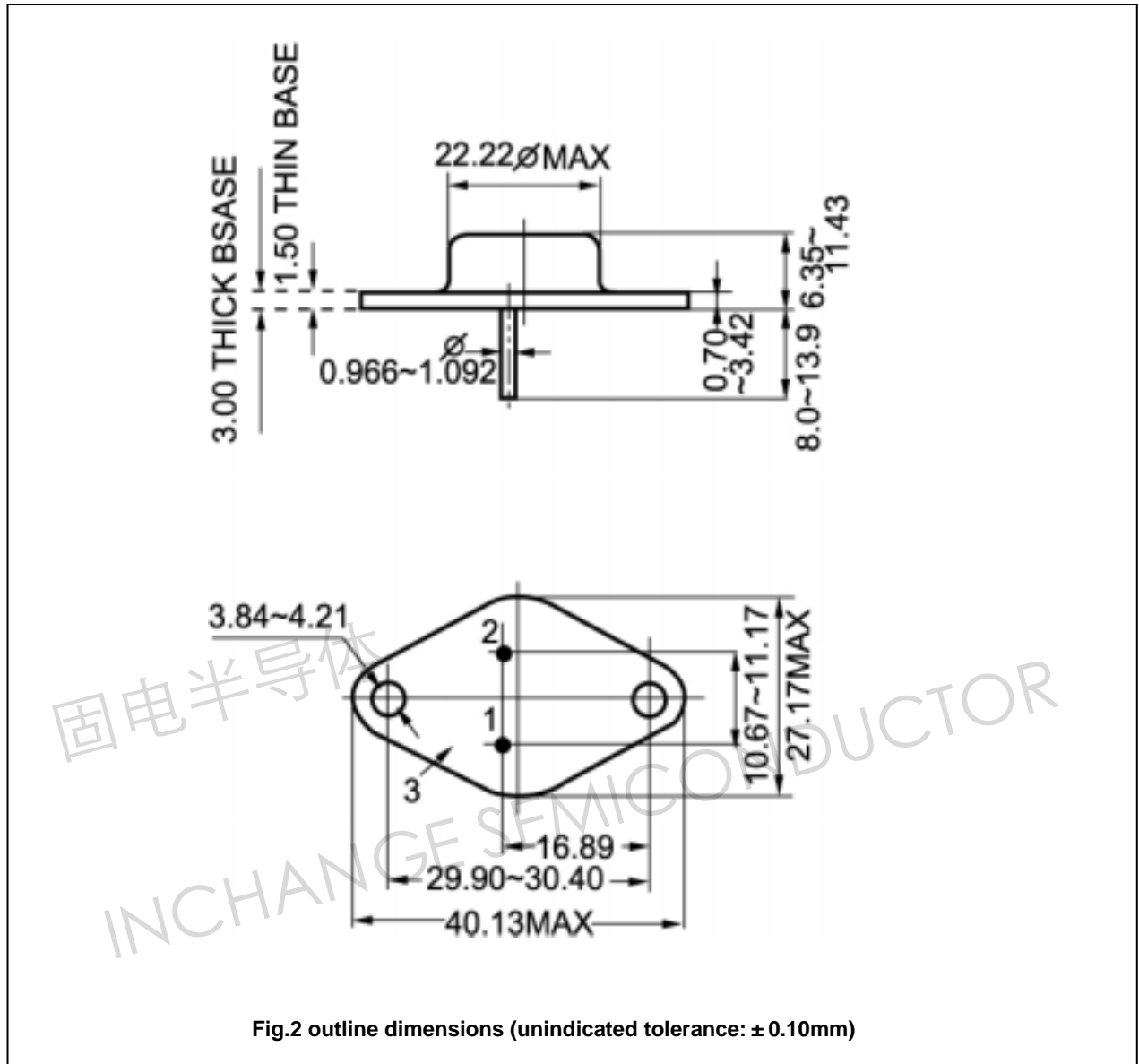

Fig.2 outline dimensions (unindicated tolerance: ± 0.10 mm)