

Silicon PNP Power Transistors

2SA764

DESCRIPTION

- With TO-66 package
- Low collector saturation voltage
- Complement to type 2SC1444

APPLICATIONS

- Desinged for general-purpose power amplifier and applications

PINNING(see Fig.2)

PIN	DESCRIPTION
1	Base
2	Emitter
3	Collector

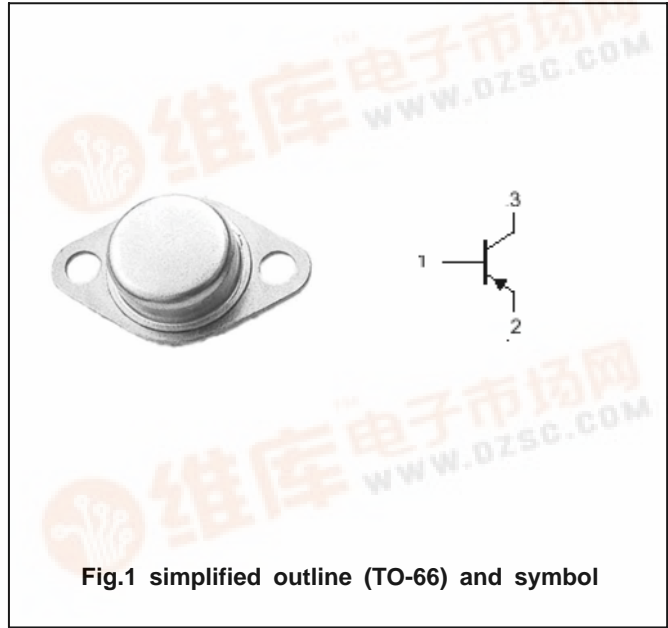

Absolute maximum ratings(Ta=°C)

SYMBOL	PARAMETER	CONDITIONS	VALUE	UNIT
V _{CBO}	Collector-base voltage	Open emitter	-60	V
V _{CEO}	Collector-emitter voltage	Open base	-60	V
V _{EBO}	Emitter-base voltage	Open collector	-6	V
I _c	Collector current		-6	A
P _c	Collector power dissipation	T _c =25°C	40	W
T _j	Junction temperature		150	°C
T _{stg}	Storage temperature		-55~150	°C

Silicon PNP Power Transistors

2SA764

CHARACTERISTICS

T_j=25°C unless otherwise specified

SYMBOL	PARAMETER	CONDITIONS	MIN	TYP.	MAX	UNIT
V _{(BR)CEO}	Collector-emitter breakdown voltage	I _C =-10mA ; I _B =0	-60			V
V _{(BR)CBO}	Collector-base breakdown voltage	I _C =-1mA ; I _E =0	-60			V
V _{CEsat}	Collector-emitter saturation voltage	I _C =-4A; I _B =-0.4A			-1.5	V
V _{BEsat}	Base-emitter saturation voltage	I _C =-4A; I _B =-0.4A			-2.0	V
I _{CBO}	Collector cut-off current	V _{CB} =-60V; I _E =0			-10	μ A
I _{EBO}	Emitter cut-off current	V _{EB} =-6V; I _C =0			-10	μ A
h _{FE}	DC current gain	I _C =-1A ; V _{CE} =-4V	50			
f _T	Transition frequency	I _C =-0.5A ; V _{CE} =-12V		10		MHz

Silicon PNP Power Transistors

2SA764

PACKAGE OUTLINE

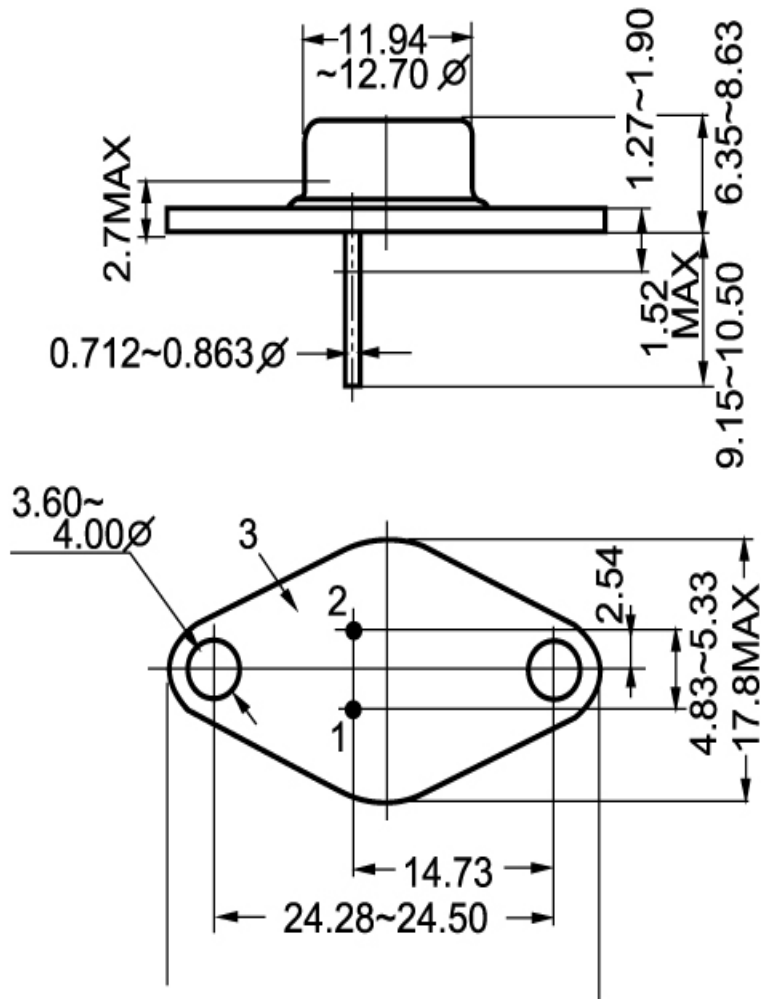

Fig.2 outline dimensions