

Inchange Semiconductor

Product Specification

Silicon PNP Power Transistors

2SB1605 2SB1605A

DESCRIPTION

- With TO-220F package
- Low collector saturation voltage
- Good linearity of h_{FE}

APPLICATIONS

- For low-voltage switching applications

PINNING

PIN	DESCRIPTION
1	Base
2	Collector
3	Emitter

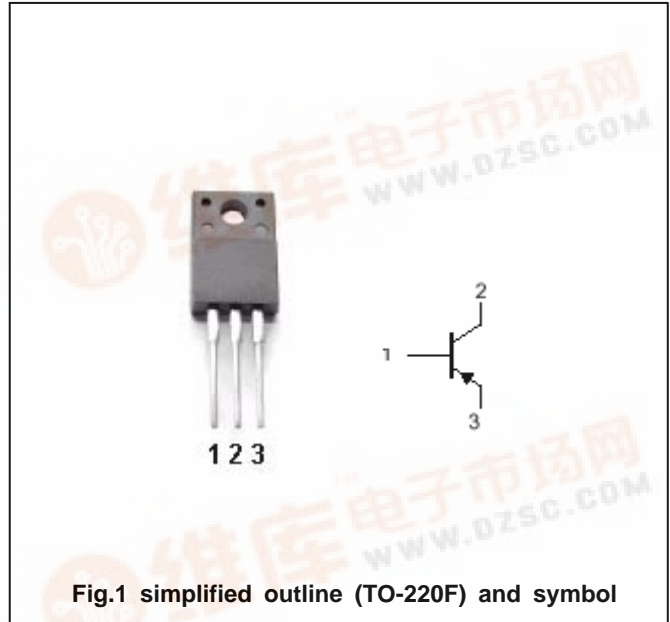

Absolute maximum ratings (Ta=25)

SYMBOL	PARAMETER	CONDITIONS	MAX	UNIT
V _{CBO}	Collector-base voltage	2SB1605	-60	V
		2SB1605A	-80	
V _{CEO}	Collector-emitter voltage	2SB1605	-60	V
		2SB1605A	-80	
V _{EBO}	Emitter-base voltage	Open collector	-5	V
I _C	Collector current		-3	A
I _{CM}	Collector current-peak		-5	A
P _C	Collector dissipation	T _a =25	2	W
		T _C =25	35	
T _j	Junction temperature		150	
T _{stg}	Storage temperature		-55~150	

Silicon PNP Power Transistors

2SB1605 2SB1605A

CHARACTERISTICS

T_j=25 unless otherwise specified

SYMBOL	PARAMETER		CONDITIONS	MIN	TYP.	MAX	UNIT
V _{(BR)CEO}	Collector-emitter breakdown voltage	2SB1605	I _C =-30mA ; I _B =0	-60			V
		2SB1605A		-80			
V _{CEsat}	Collector-emitter saturation voltage		I _C =-3A ; I _B =-0.375A			-1.2	V
V _{BE}	Base-emitter on voltage		I _C =-3A ; V _{CE} =-4V			-1.8	V
I _{CES}	Collector cut-off current	2SB1605	V _{CE} =-60V ; V _{BE} =0			-200	μA
		2SB1605A	V _{CE} =-80V ; V _{BE} =0				
I _{CEO}	Collector cut-off current	2SB1605	V _{CE} =-30V ; I _B =0			-300	μA
		2SB1605A	V _{CE} =-60V ; I _B =0				
I _{EBO}	Emitter cut-off current		V _{EB} =-5V ; I _C =0			-1	mA
h _{FE-1}	DC current gain		I _C =-1A ; V _{CE} =-4V	70		250	
h _{FE-2}	DC current gain		I _C =-3A ; V _{CE} =-4V	10			
f _T	Transition frequency		I _C =-0.5A ; V _{CE} =-10V		30		MHz

Switching times

t _{on}	Turn-on time	I _C =-1A ; I _{B1} =-I _{B2} =-0.1A		0.5		μs
t _{stg}	Storage time			1.2		μs
t _f	Fall time			0.3		μs

◆ h_{FE-1} Classifications

Q	P
70-150	120-250

Silicon PNP Power Transistors

2SB1605 2SB1605A

PACKAGE OUTLINE

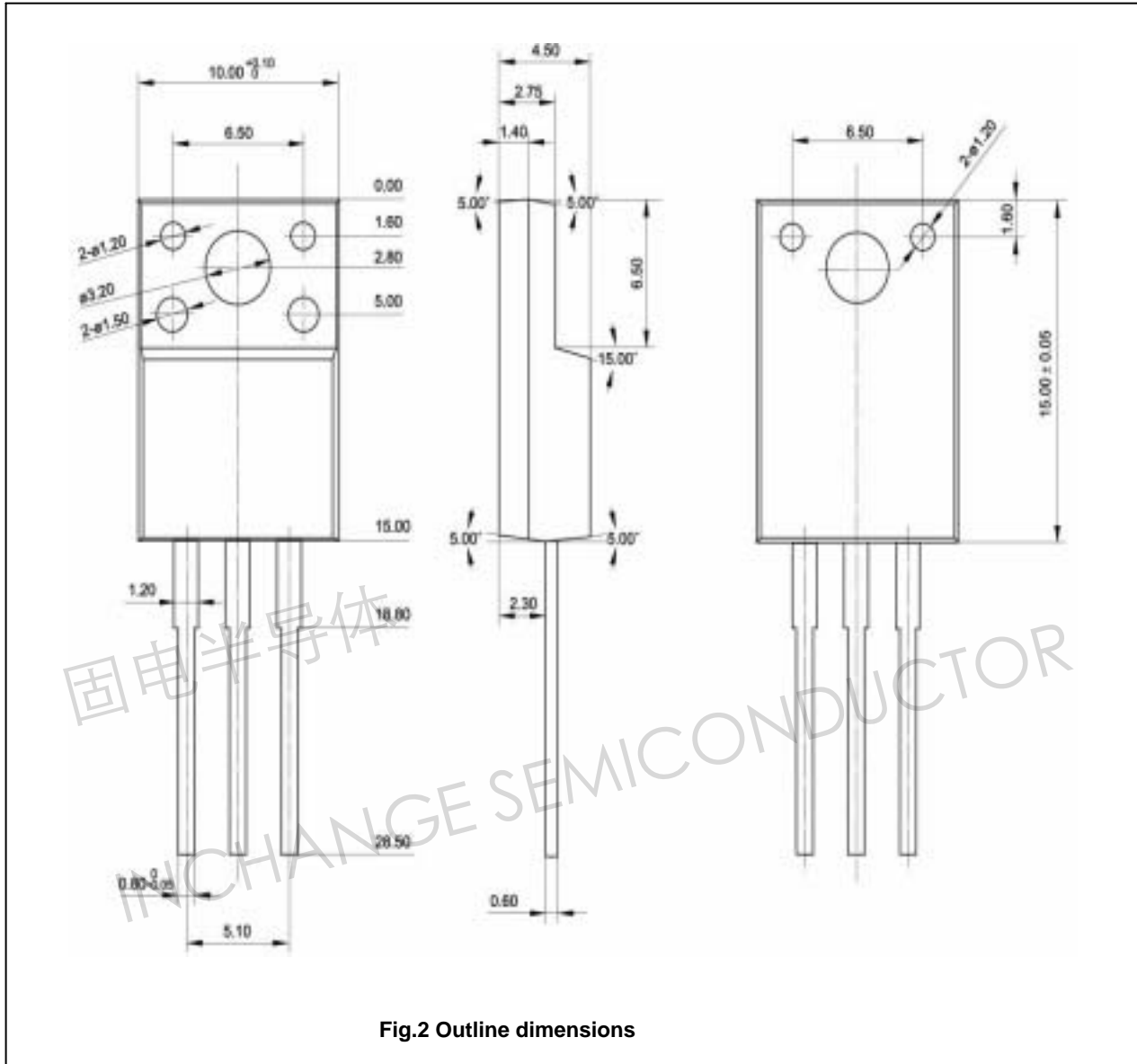

Silicon PNP Power Transistors

2SB1605 2SB1605A

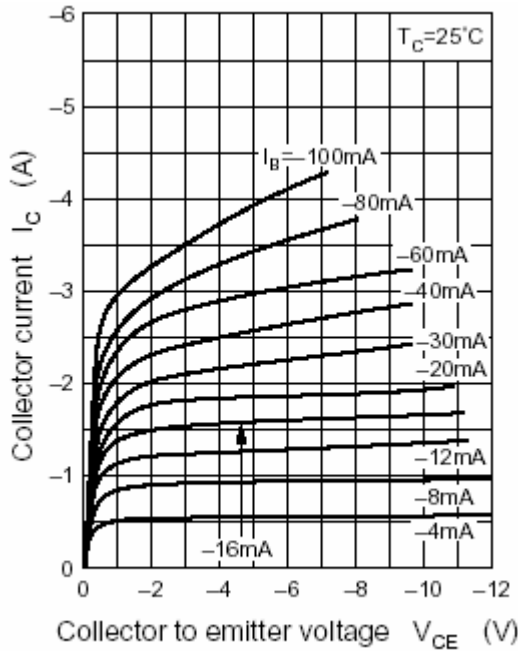

Fig.3 Static Characteristic

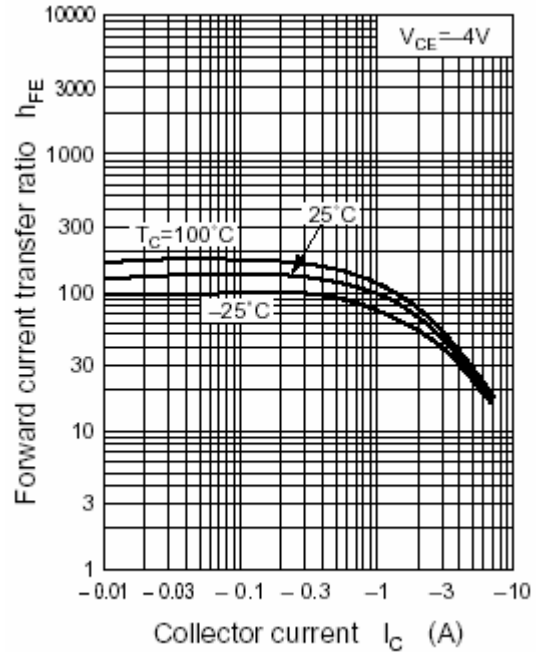

Fig.4 DC current Gain

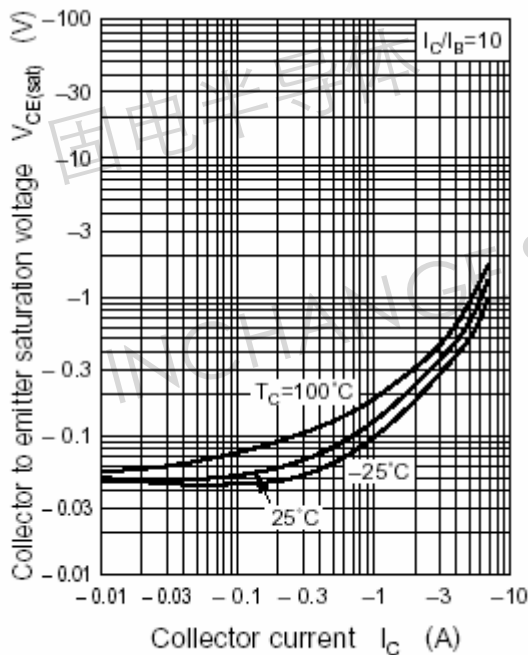

Fig.5 Collector-Emitter Saturation Voltage

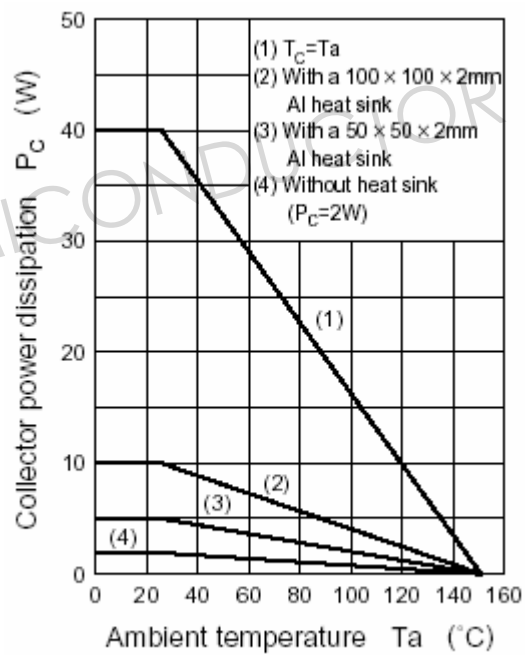

Fig.4 Power Derating