

Inchange Semiconductor

Product Specification

Silicon NPN Power Transistors

2SD476 2SD476A

DESCRIPTION

- With TO-220C package
- Complement to type 2SB566/566A

APPLICATIONS

- For low frequency power amplifier power switching applications

PINNING

PIN	DESCRIPTION
1	Base
2	Collector;connected to mounting base
3	Emitter

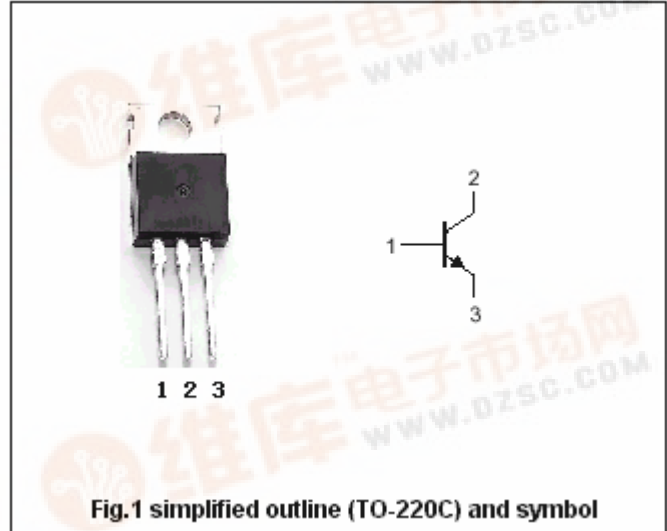

Absolute maximum ratings(Tc=25)

SYMBOL	PARAMETER	CONDITIONS	VALUE	UNIT
V _{CBO}	Collector-base voltage	Open emitter	70	V
V _{CEO}	Collector-emitter voltage	2SD476	50	V
		2SD476A	60	
V _{EBO}	Emitter-base voltage	Open collector	5	V
I _C	Collector current		4	A
I _{CM}	Collector current-peak		8	A
P _C	Collector power dissipation	T _C =25	40	W
T _j	Junction temperature		150	
T _{stg}	Storage temperature		-55~150	

Silicon NPN Power Transistors

2SD476 2SD476A

CHARACTERISTICS

T_j=25 unless otherwise specified

SYMBOL	PARAMETER		CONDITIONS	MIN	TYP.	MAX	UNIT
V _{(BR)CBO}	Collector-base breakdown voltage		I _C =10 μA ; I _E =0	70			V
V _{(BR)CEO}	Collector-emitter breakdown voltage	2SD476	I _C =50mA; R _{BE} =	50			V
		2SD476A		60			
V _{(BR)EBO}	Emitter-base breakdown voltage		I _E =10 μA ; I _C =0	5			V
V _{CEsat}	Collector-emitter saturation voltage		I _C =2 A; I _B =0.2 A			1.0	V
V _{BEsat}	Base-emitter saturation voltage		I _C =2 A; I _B =0.2 A			1.2	V
I _{CBO}	Collector cut-off current		V _{CB} =50V; I _E =0			1	μA
h _{FE-1}	DC current gain		I _C =0.1A ; V _{CE} =4V	35			
h _{FE-2}	DC current gain		I _C =1A ; V _{CE} =4V	60		200	
f _T	Transition frequency		I _C =0.5A ; V _{CE} =4V		7		MHz

Switching times

t _{on}	Turn-on time	I _C =0.5A ; V _{CC} =10.5V I _{B1} =-I _{B2} =0.05 A		0.3		μs
t _{off}	Turn-off time			3.0		μs
t _{stg}	Storage time			2.5		μs

◆ h_{FE-2} classifications

B	C
60-120	100-200

Silicon NPN Power Transistors

2SD476 2SD476A

PACKAGE OUTLINE

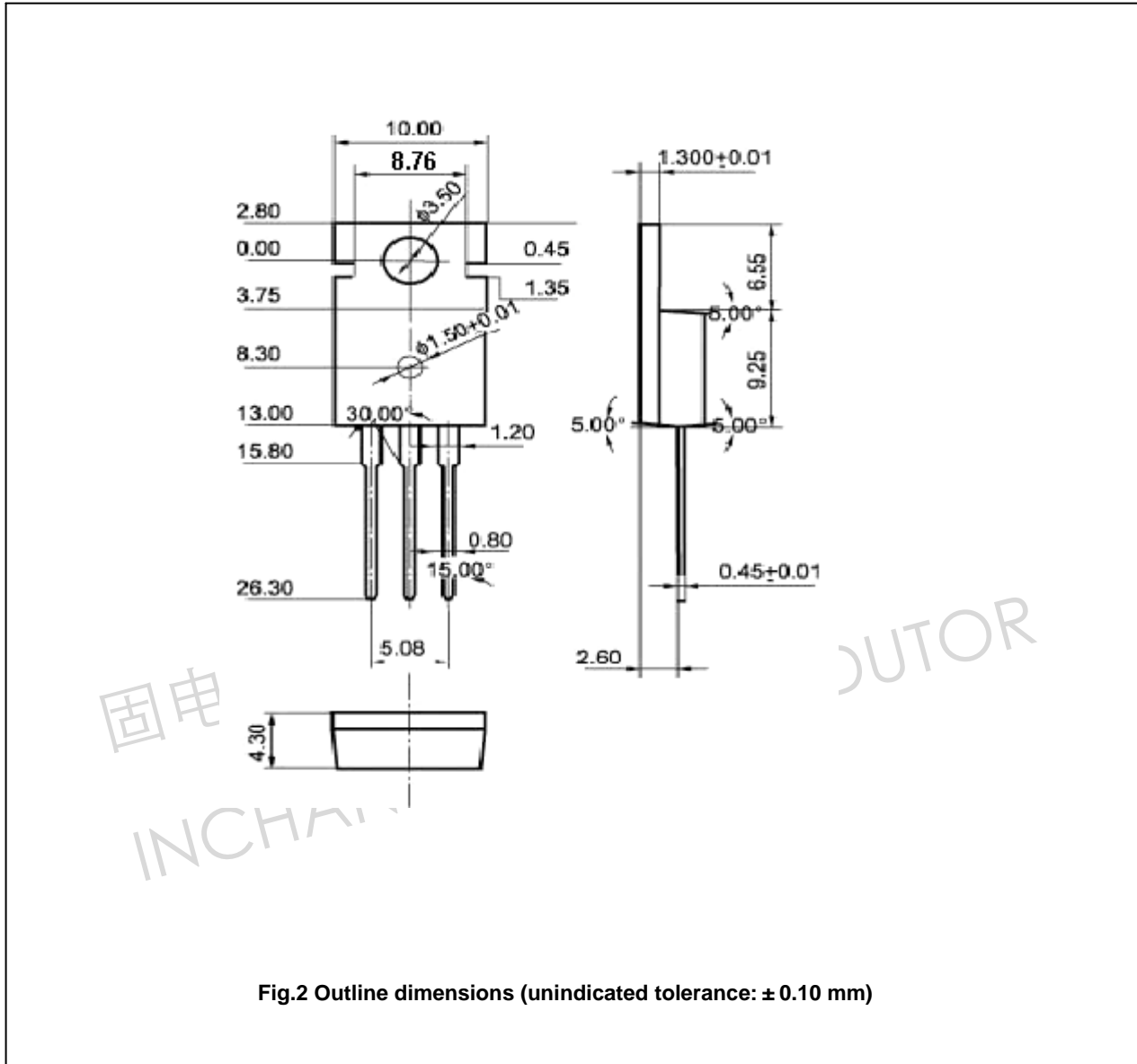

Silicon NPN Power Transistors

2SD476 2SD476A

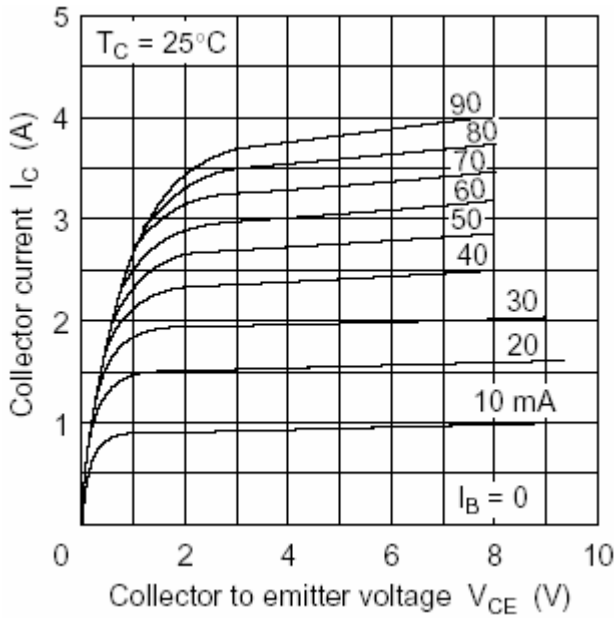

Fig.3 Static Characteristic

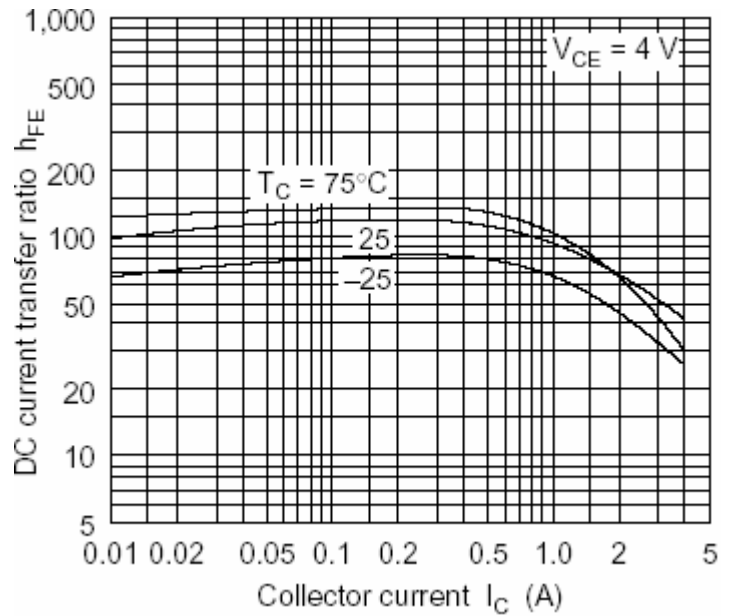

Fig.4 DC current Gain

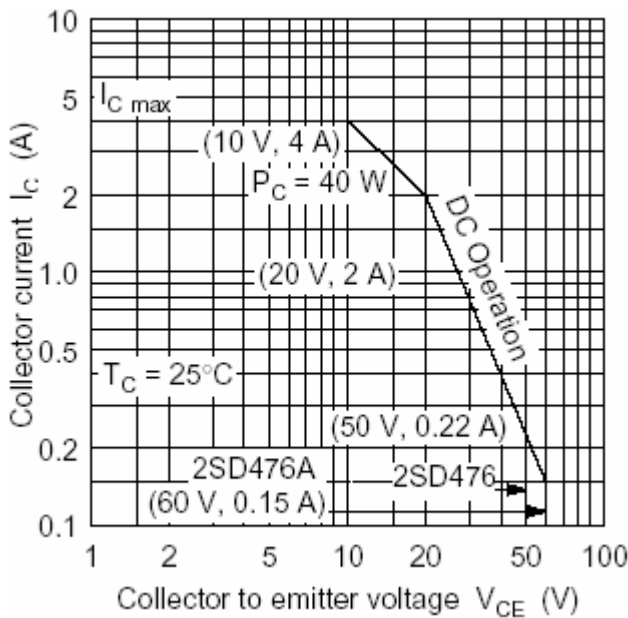

Fig.5 Safe Operating Area

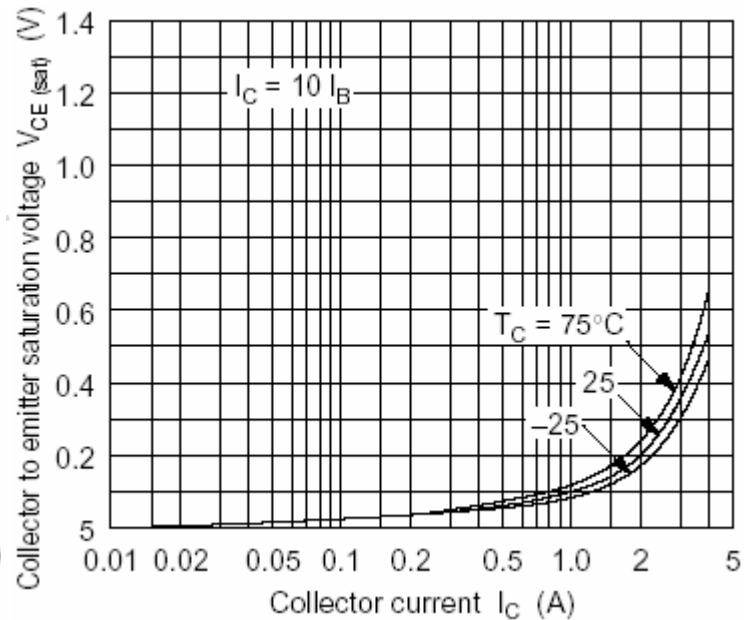

Fig.6 Collector-Emitter Saturation Voltage