

Silicon NPN Power Transistors

TIP31/31A/31B/31C

DESCRIPTION

- With TO-220C package
- Complement to type TIP32/32A/32B/32C

APPLICATIONS

- Medium power linear switching applications

PINNING

PIN	DESCRIPTION
1	Base
2	Collector;connected to mounting base
3	Emitter

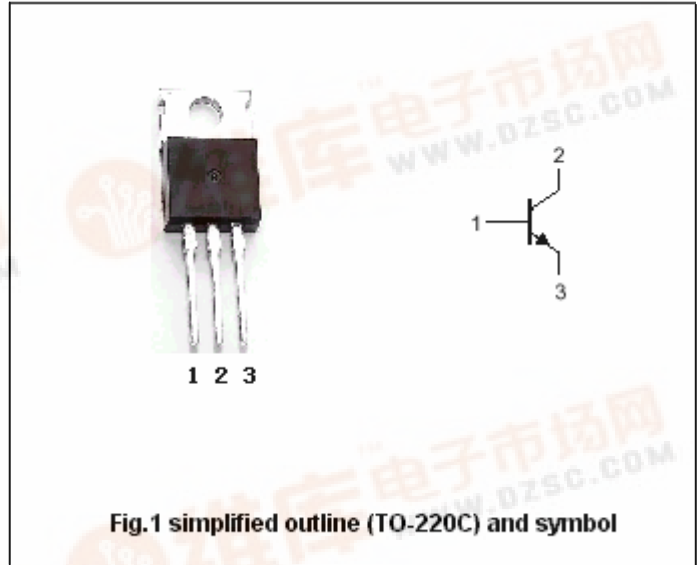

Absolute maximum ratings(Ta=25 )

SYMBOL	PARAMETER	CONDITIONS	VALUE	UNIT
V <sub>CBO</sub>	Collector-base voltage	TIP31	40	V
		TIP31A	60	
		TIP31B	80	
		TIP31C	100	
V <sub>CEO</sub>	Collector-emitter voltage	TIP31	40	V
		TIP31A	60	
		TIP31B	80	
		TIP31C	100	
V <sub>EBO</sub>	Emitter-base voltage	Open collector	5	V
I <sub>C</sub>	Collector current (DC)		3	A
I <sub>CM</sub>	Collector current-Pulse		5	A
I <sub>B</sub>	Base current		1	A
P <sub>C</sub>	Collector power dissipation	T <sub>C</sub> =25	40	w
		T <sub>a</sub> =25	2	
T <sub>j</sub>	Junction temperature		150	
T <sub>stg</sub>	Storage temperature		-65~150	

## Silicon NPN Power Transistors

## TIP31/31A/31B/31C

## CHARACTERISTICS

T<sub>j</sub>=25 unless otherwise specified

SYMBOL	PARAMETER	CONDITIONS	MIN	TYP.	MAX	UNIT
V <sub>CEO(SUS)</sub>	Collector-emitter sustaining voltage	TIP31	40			V
		TIP31A	60			
		TIP31B	80			
		TIP31C	100			
		I <sub>C</sub> =30mA; I <sub>B</sub> =0				
V <sub>CEsat</sub>	Collector-emitter saturation voltage	I <sub>C</sub> =3A I <sub>B</sub> =0.375A			1.2	V
V <sub>BE</sub>	Base-emitter on voltage	I <sub>C</sub> =3A ; V <sub>CE</sub> =4V			1.8	V
I <sub>CES</sub>	Collector cut-off current	TIP31	V <sub>CE</sub> =40V; V <sub>EB</sub> =0		0.2	mA
		TIP31A	V <sub>CE</sub> =60V; V <sub>EB</sub> =0			
		TIP31B	V <sub>CE</sub> =80V; V <sub>EB</sub> =0			
		TIP31C	V <sub>CE</sub> =100V; V <sub>EB</sub> =0			
I <sub>CEO</sub>	Collector cut-off current	TIP31/31A	V <sub>CE</sub> =30V; I <sub>B</sub> =0		0.3	mA
		TIP31B/31C	V <sub>CE</sub> =60V; I <sub>B</sub> =0			
I <sub>EBO</sub>	Emitter cut-off current	V <sub>EB</sub> =5V; I <sub>C</sub> =0			1.0	mA
h <sub>FE-1</sub>	DC current gain	I <sub>C</sub> =1A ; V <sub>CE</sub> =4V	25			
h <sub>FE-2</sub>	DC current gain	I <sub>C</sub> =3A ; V <sub>CE</sub> =4V	10		50	
f <sub>T</sub>	Transiton frequency	I <sub>C</sub> =0.5A ; V <sub>CE</sub> =10V	3			MHz

Silicon NPN Power Transistors

TIP31/31A/31B/31C

PACKAGE OUTLINE

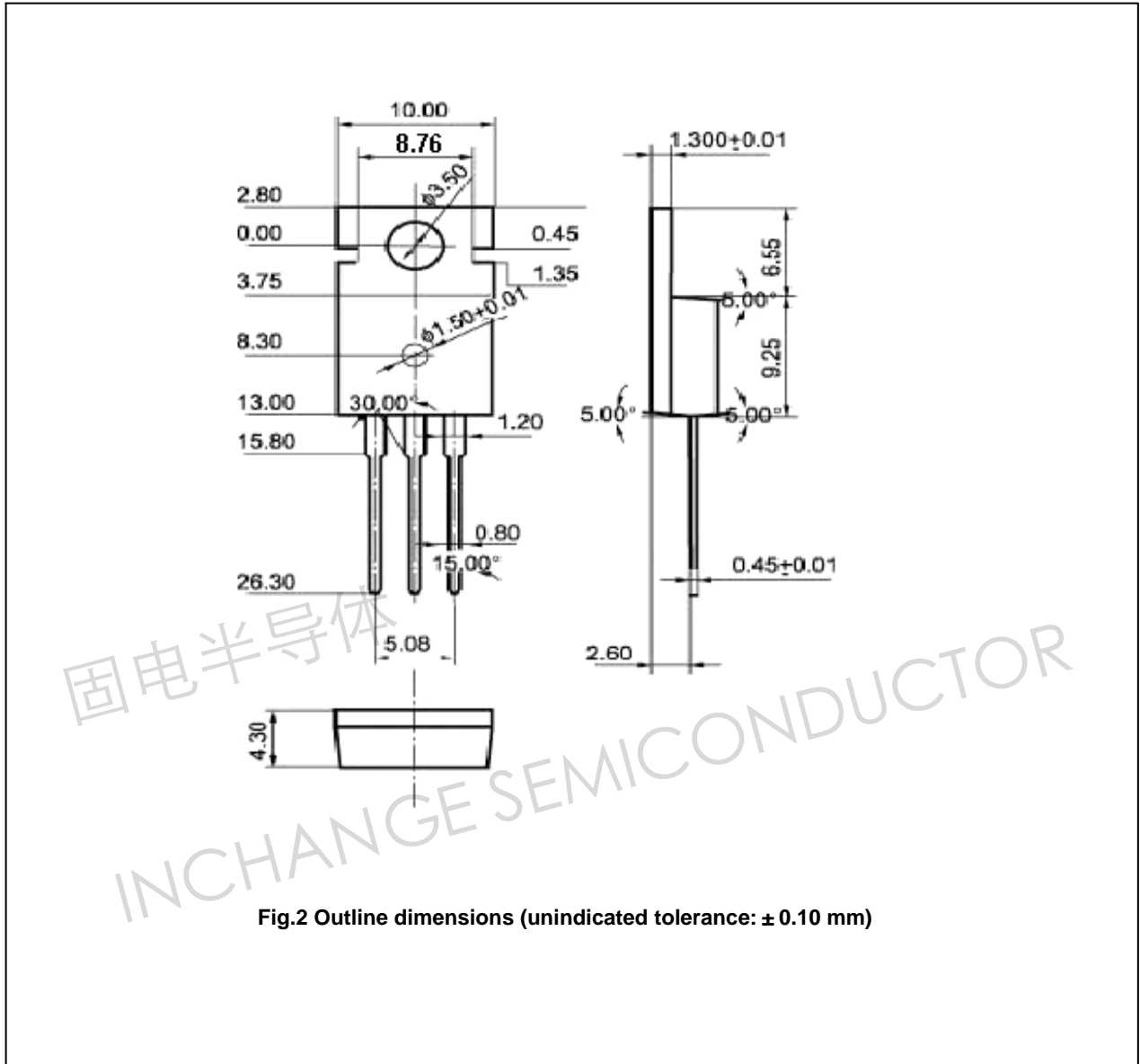

Fig.2 Outline dimensions (unindicated tolerance: ± 0.10 mm)

Silicon NPN Power Transistors

TIP31/31A/31B/31C

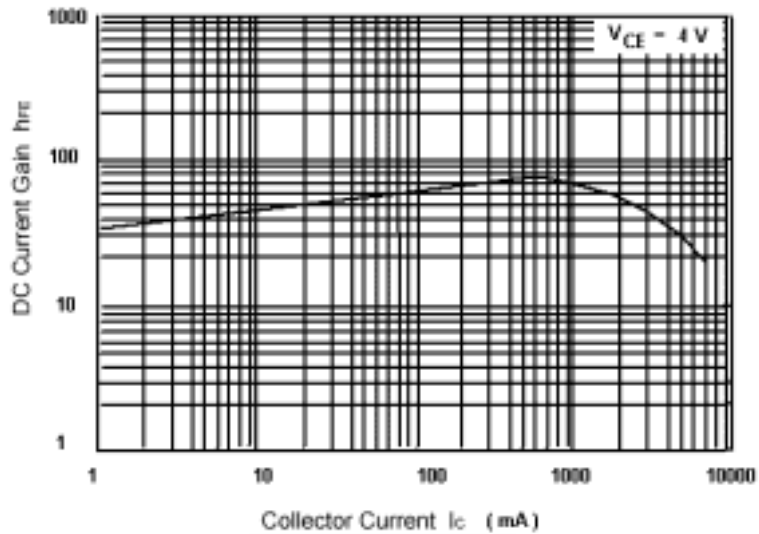

Fig.3 DC current Gain

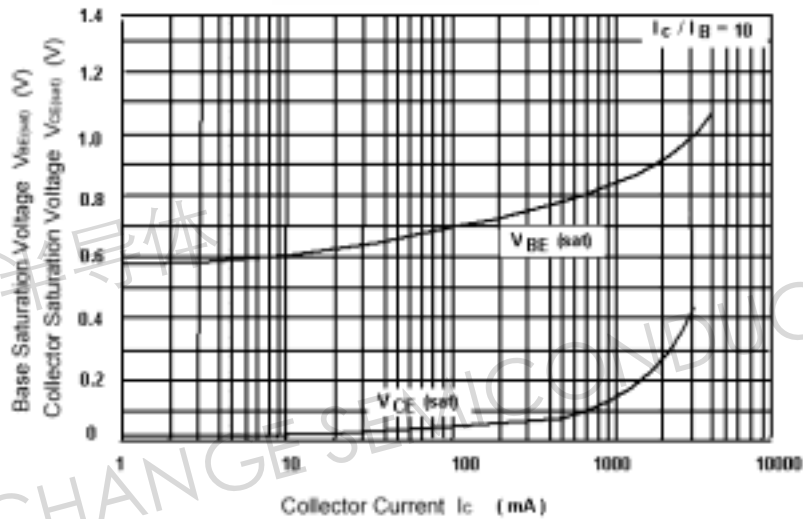

Fig.4 Base-Emitter Saturation Voltage  
Collector-Emitter Saturation Voltage

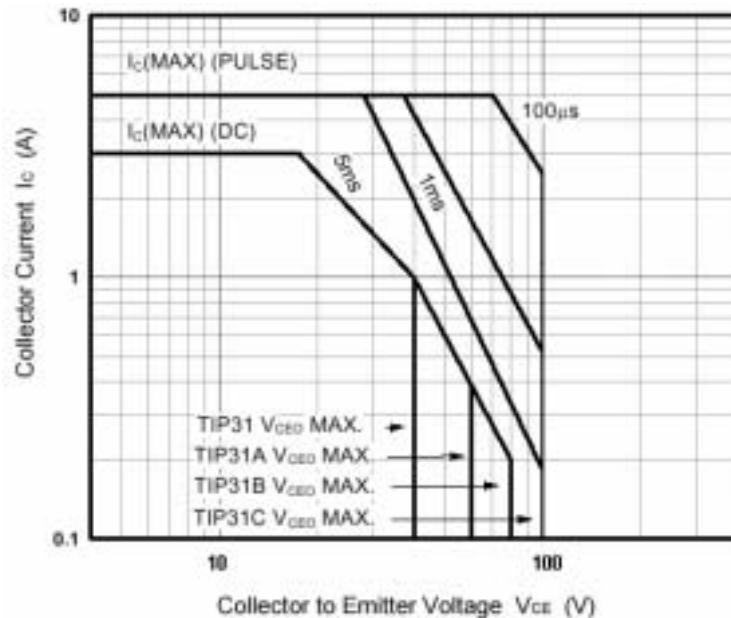

Fig.5 Safe Operating Area