

Silicon PNP Power Transistors

2SB514

DESCRIPTION

- With TO-220C package
- Complement to type 2SD330
- Low collector saturation voltage

APPLICATIONS

- Suited for use in output stage of 10W AF power amplifier

PINNING

PIN	DESCRIPTION
1	Emitter
2	Collector;connected to mounting base
3	Base



Absolute maximum ratings(Ta=25 )

SYMBOL	PARAMETER	CONDITIONS	VALUE	UNIT
V <sub>CBO</sub>	Collector-base voltage	Open emitter	-50	V
V <sub>CEO</sub>	Collector-emitter voltage	Open base	-50	V
V <sub>EBO</sub>	Emitter-base voltage	Open collector	-5	V
I <sub>C</sub>	Collector current (DC)		-2	A
I <sub>CM</sub>	Collector current-Peak		-5	A
P <sub>C</sub>	Collector dissipation	T <sub>a</sub> =25	1.75	W
		T <sub>C</sub> =25	20	
T <sub>j</sub>	Junction temperature		150	
T <sub>stg</sub>	Storage temperature		-50~150	

## Silicon PNP Power Transistors

## 2SB514

## CHARACTERISTICS

T<sub>j</sub>=25 unless otherwise specified

SYMBOL	PARAMETER	CONDITIONS	MIN	TYP.	MAX	UNIT
V <sub>CEO</sub>	Collector-emitter voltage	I <sub>C</sub> =-10mA; I <sub>B</sub> =0	-50			V
V <sub>CEsat</sub>	Collector-emitter saturation voltage	I <sub>C</sub> =-2A; I <sub>B</sub> =-0.2A			-1.0	V
V <sub>BE</sub>	Base-emitter on voltage	I <sub>C</sub> =-1A; V <sub>CE</sub> =-5V			-1.5	V
I <sub>CBO</sub>	Collector cut-off current	V <sub>CB</sub> =-20V; I <sub>E</sub> =0			-0.1	mA
I <sub>EBO</sub>	Emitter cut-off current	V <sub>EB</sub> =-4V; I <sub>C</sub> =0			-1.0	mA
h <sub>FE-1</sub>	DC current gain	I <sub>C</sub> =-1A; V <sub>CE</sub> =-2V	40		320	
h <sub>FE-2</sub>	DC current gain	I <sub>C</sub> =-0.1A; V <sub>CE</sub> =-2V	35			
f <sub>T</sub>	Transition frequency	I <sub>C</sub> =-0.5A; V <sub>CE</sub> =-5V		8		MHz

◆ h<sub>FE-1</sub> Classifications

C	D	E	F
40-80	60-120	100-200	160-320

PACKAGE OUTLINE

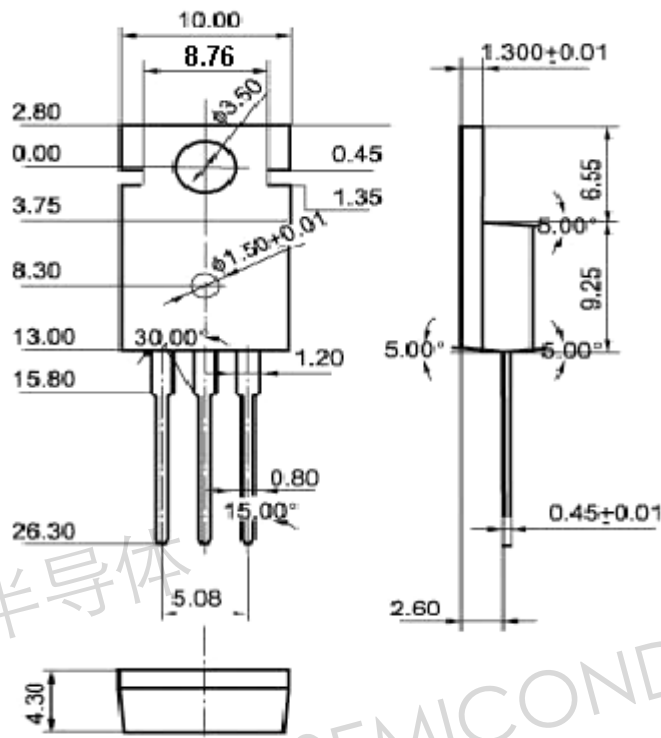

Fig.2 Outline dimensions (unindicated tolerance: ± 0.10mm)