

Inchange Semiconductor

Product Specification

Silicon PNP Power Transistors

2SB566 2SB566A

DESCRIPTION

- With TO-220C package
- Complement to type 2SD476/476A

APPLICATIONS

- For low frequency power amplifier power switching applications

PINNING

PIN	DESCRIPTION
1	Emitter
2	Collector;connected to mounting base
3	Base

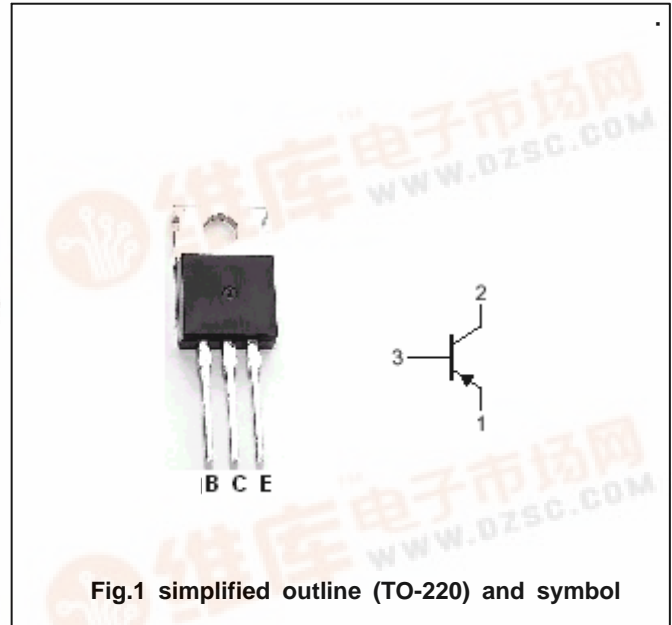

Fig.1 simplified outline (TO-220) and symbol

Absolute maximum ratings(Tc=25)

SYMBOL	PARAMETER	CONDITIONS	VALUE	UNIT
V _{CBO}	Collector-base voltage	Open emitter	-70	V
V _{CEO}	Collector-emitter voltage	2SB566	-50	V
		2SB566A	-60	
V _{EBO}	Emitter-base voltage	Open collector	-5	V
I _C	Collector current		-4	A
I _{CM}	Collector current-peak		-8	A
P _C	Collector power dissipation	T _C =25	40	W
T _j	Junction temperature		150	
T _{stg}	Storage temperature		-55~150	

Silicon PNP Power Transistors

2SB566 2SB566A

CHARACTERISTICS

T_j=25 unless otherwise specified

SYMBOL	PARAMETER	CONDITIONS	MIN	TYP.	MAX	UNIT
V _{(BR)CBO}	Collector-base breakdown voltage	I _C =-10 μ A ; I _E =0	-70			V
V _{(BR)CEO}	Collector-emitter breakdown voltage	I _C =-50mA; R _{BE} =	2SB566	-50		V
			2SB566A	-60		
V _{(BR)EBO}	Emitter-base breakdown voltage	I _E =-10 μ A ; I _C =0	-5			V
V _{CEsat}	Collector-emitter saturation voltage	I _C =-2 A; I _B =-0.2 A			-1.0	V
V _{BEsat}	Base-emitter saturation voltage	I _C =-2 A; I _B =-0.2 A			-1.2	V
I _{CBO}	Collector cut-off current	V _{CB} =-50V; I _E =0			-1	μ A
h _{FE-1}	DC current gain	I _C =-0.1A ; V _{CE} =-4V	35			
h _{FE-2}	DC current gain	I _C =-1A ; V _{CE} =-4V	60		200	
f _T	Transition frequency	I _C =-0.5A ; V _{CE} =-4V		15		MHz

Switching times

t _{on}	Turn-on time	I _C =-0.5A ; V _{CC} =-10.5V I _{B1} =-I _{B2} =-0.05 A		0.3		μ s
t _{off}	Turn-off time			3.0		μ s
t _{stg}	Storage time			2.5		μ s

◆ h_{FE-2} classifications

B	C
60-120	100-200

Silicon PNP Power Transistors

2SB566 2SB566A

PACKAGE OUTLINE

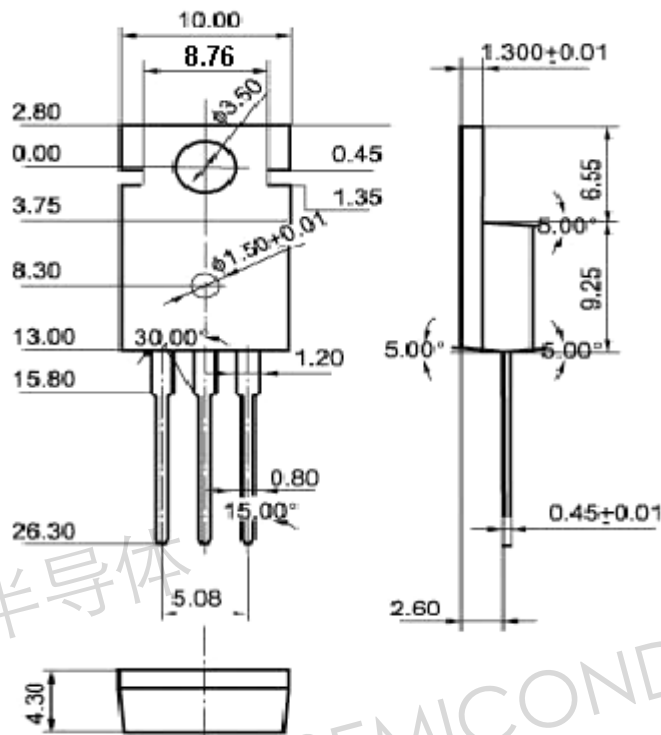

Fig.2 Outline dimensions (unindicated tolerance: ± 0.10 mm)

Silicon PNP Power Transistors

2SB566 2SB566A

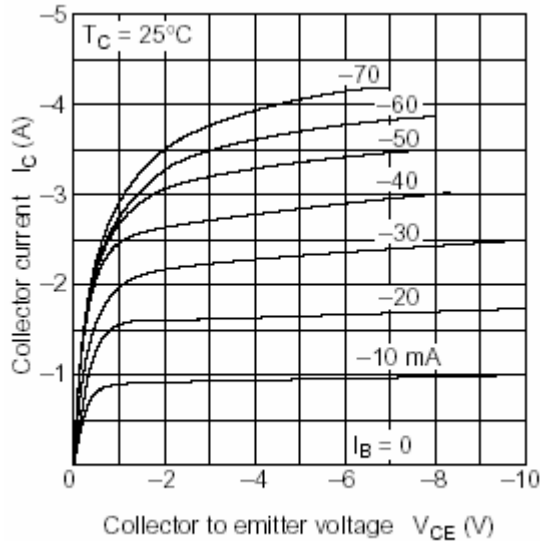

Fig.3 Static Characteristic

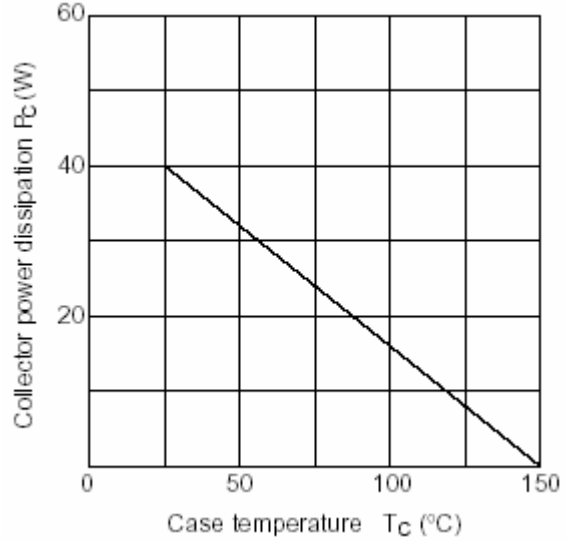

Fig.4 Power Derating

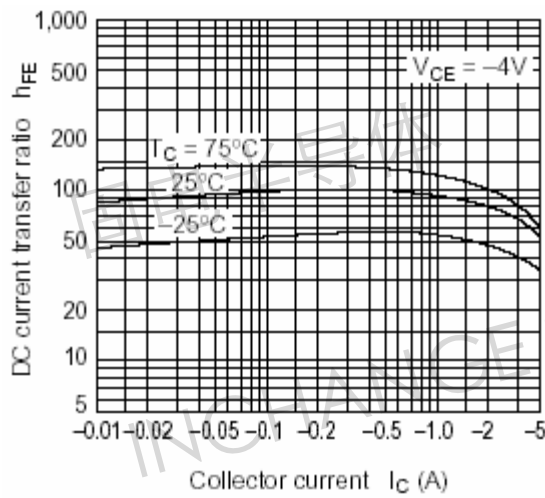

Fig.5 DC current Gain

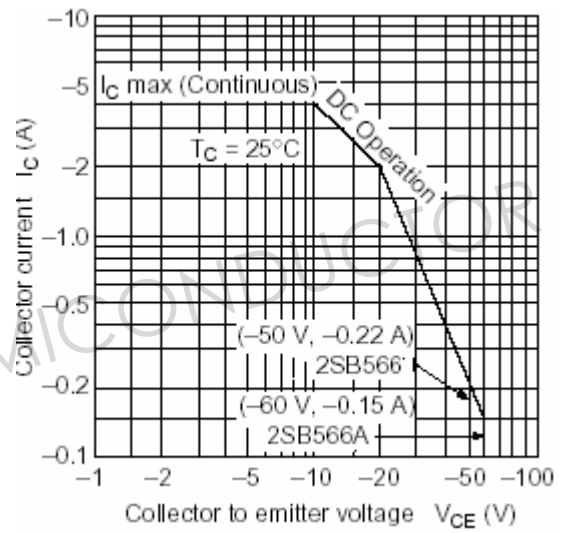

Fig.6 Safe Operating Area

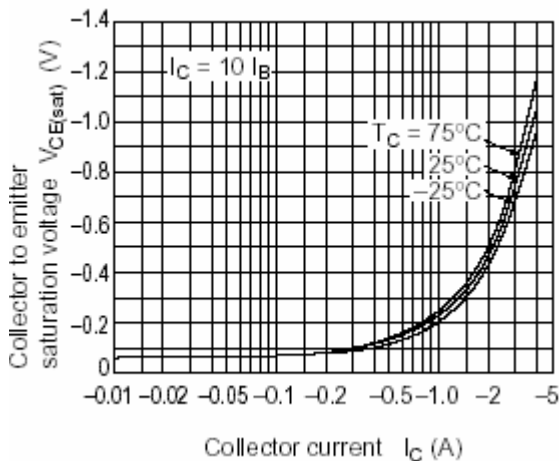

Fig.7 Collector-Emitter Saturation Voltage