



LT3491

White LED Driver with Integrated Schottky in SC70 and 2mm × 2mm DFN

FEATURES

- Drives Up to Six White LEDs from a 3V Supply
- High Side Sense Allows “One Wire Current Source”
- Internal Schottky Diode
- One Pin Dimming and Shutdown
- 27V Open LED Protection
- 2.3MHz Switching Frequency
- ±5% Reference Accuracy
- V_{IN} Range: 2.5V to 12V
- Requires Only 1 μ F Output Capacitor
- Wide 300:1 True Color PWM™ Dimming Range
- 8-Lead SC70 Package
- Low Profile 6-Lead DFN Package (2mm × 2mm × 0.75mm)

APPLICATIONS

- Cellular Phones
- PDAs, Handheld Computers
- Digital Cameras
- MP3 Players
- GPS Receivers

DESCRIPTION

The LT[®]3491 is a fixed frequency step-up DC/DC converter specifically designed to drive up to six white LEDs in series from a Li-Ion cell. Series connection of the LEDs provides identical LED currents resulting in uniform brightness and eliminating the need for ballast resistors. The device features a unique high side LED current sense that enables the part to function as a “one wire current source;” one side of the LED string can be returned to ground anywhere, allowing a simpler one wire LED connection. Traditional LED drivers use a grounded resistor to sense LED current, requiring a 2-wire connection to the LED string.

The 2.3MHz switching frequency allows the use of tiny inductors and capacitors. A single pin performs both shutdown and accurate LED dimming control. Few external components are needed: open-LED protection and the Schottky diode are all contained inside the tiny SC70 and 2mm × 2mm DFN packages. With such a high level of integration, the LT3491 provides a high efficiency LED driver solution in the smallest of spaces.

LT, LTC, LT and LTM are registered trademarks of Linear Technology Corporation. All other trademarks are the property of their respective owners.

TYPICAL APPLICATION

Li-Ion Driver for Four White LEDs

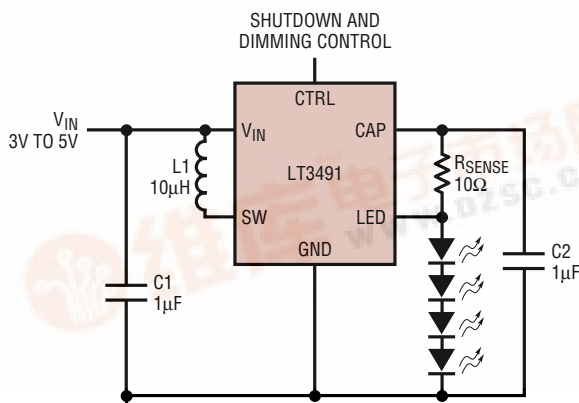

C1: TAIYO YUDEN LMK212BJ105MD
 C2: TAIYO YUDEN GMK316BJ105ML
 L1: MURATA LQH32CN100

Efficiency

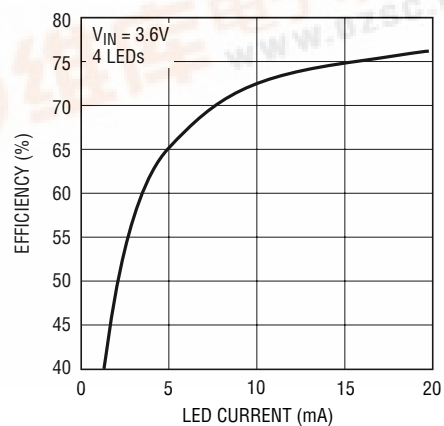

3491 TA01b

LT3491

ABSOLUTE MAXIMUM RATINGS (Note 1)

Input Voltage (V_{IN})	12V	LED Voltage	32V
SW Voltage	32V	Operating Temperature Range (Note 2) ..	-40°C to 85°C
CAP Voltage	32V	Maximum Junction Temperature	125°C
CTRL Voltage	12V	Storage Temperature Range	-65°C to 150°C
		Lead Temperature (Soldering, 10sec, SC-70)	300°C

PACKAGE/ORDER INFORMATION

<p>DC PACKAGE 6-LEAD (2mm x 2mm) PLASTIC DFN</p> <p>$T_{JMAX} = 125^{\circ}\text{C}$, $\theta_{JA} = 102^{\circ}\text{C/W}$, $\theta_{JC} = 20^{\circ}\text{C/W}$ EXPOSED PAD (PIN 7) SHOULD BE CONNECTED TO PCB GROUND</p>		<p>SC8 PACKAGE 8-LEAD PLASTIC SC70</p> <p>$T_{JMAX} = 125^{\circ}\text{C}$, $\theta_{JA} = 270^{\circ}\text{C/W}$</p>	
ORDER PART NUMBER	DC PART MARKING	ORDER PART NUMBER	DC PART MARKING
LT3491EDC	LCHJ	LT3491ESC8	LBXQ
Order Options Tape and Reel: Add #TR Lead Free: Add #PBF Lead Free Tape and Reel: Add #TRPBF Lead Free Part Marking: http://www.linear.com/leadfree/			

Consult LTC Marketing for parts specified with wider operating temperature ranges.

ELECTRICAL CHARACTERISTICS

The ● denotes specifications which apply over the full operating temperature range, otherwise specifications are $T_A = 25^{\circ}\text{C}$.
 $V_{IN} = 3\text{V}$, $V_{CTRL} = 3\text{V}$, unless otherwise specified.

PARAMETER	CONDITIONS	MIN	TYP	MAX	UNITS
Minimum Operating Voltage		2.5			V
LED Current Sense Voltage ($V_{CAP} - V_{LED}$)	$V_{CAP} = 30\text{V}$	● 190	200	210	mV
CAP, LED Pin Bias Current	$V_{CAP} = 16\text{V}$, $V_{LED} = 16\text{V}$		20	40	μA
V_{CAP} , V_{LED} Common Mode Minimum Voltage				2.5	V
Supply Current	$V_{CAP} = 16\text{V}$, $V_{LED} = 15\text{V}$, $CTRL = 3\text{V}$ $CTRL = 0\text{V}$		2.6 8	4 10	mA μA
Switching Frequency		1.8	2.3	2.8	MHz
Maximum Duty Cycle		● 88	92		%
Switch Current Limit		● 260	350		mA
Switch V_{CESAT}	$I_{SW} = 200\text{mA}$		200		mV
Switch Leakage Current	$V_{SW} = 16\text{V}$		0.1	5	μA
V_{CTRL} for Full LED Current	$V_{CAP} = 30\text{V}$	● 1.5			V
V_{CTRL} to Shut Down IC				50	mV
V_{CTRL} to Turn On IC		● 100			mV
CTRL Pin Bias Current			100		nA
CAP Pin Overvoltage Protection		● 26	27	28	V
Schottky Forward Drop	$I_{SCHOTTKY} = 100\text{mA}$		0.8		V
Schottky Leakage Current	$V_R = 20\text{V}$			4	μA

ELECTRICAL CHARACTERISTICS

Note 1: Stresses beyond those listed under Absolute Maximum Ratings may cause permanent damage to the device. Exposure to any Absolute Maximum Rating condition for extended periods may affect device reliability and lifetime.

Note 2: The LT3491E is guaranteed to meet performance specifications from 0°C to 85°C. Specifications over the -40°C to 85°C operating temperature range are assured by design, characterization and correlation with statistical process controls.

TYPICAL PERFORMANCE CHARACTERISTICS (T_A = 25°C unless otherwise specified)

Switch Saturation Voltage (V_{CESAT})

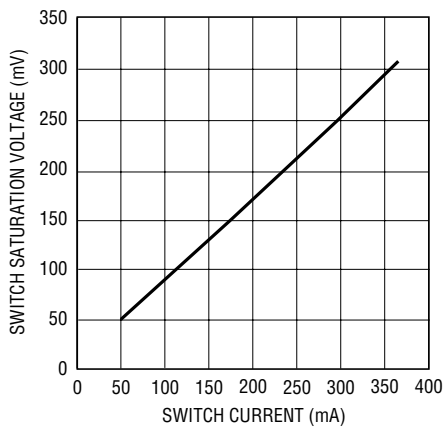

3491 G01

Schottky Forward Voltage Drop

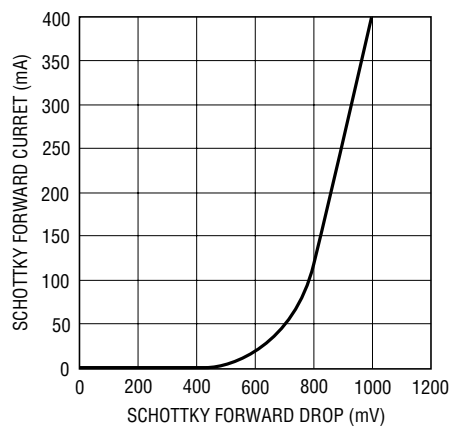

3491 G02

Shutdown Current (V_{CTRL} = 0V)

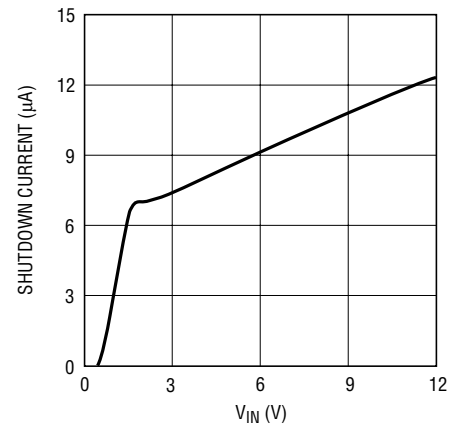

3491 G03

Sense Voltage (V_{CAP} - V_{LED}) vs V_{CTRL}

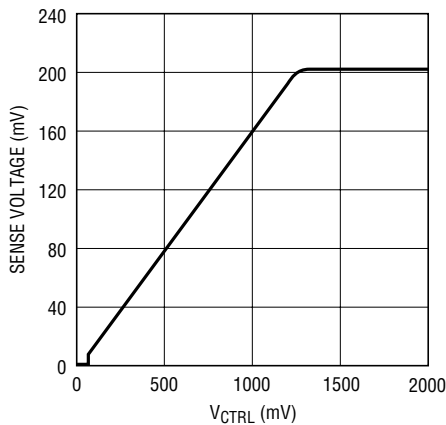

3491 G04

Open-Circuit Output Clamp Voltage

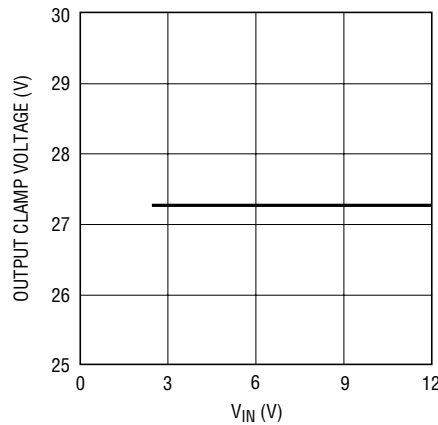

3491 G05

Input Current in Output Open Circuit

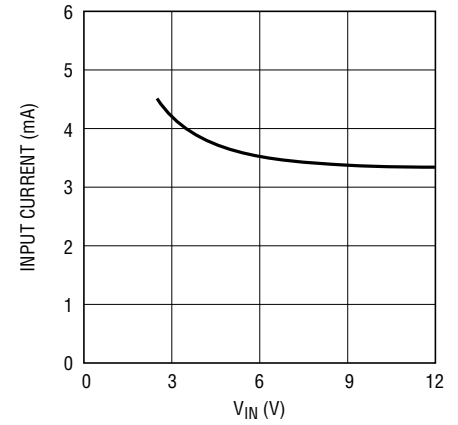

3491 G06

Switching Waveform

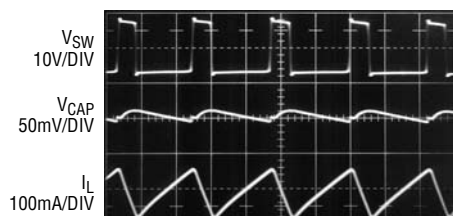

V_{IN} = 3.6V
FRONT PAGE
APPLICATION CIRCUIT

3491 G07

Transient Response

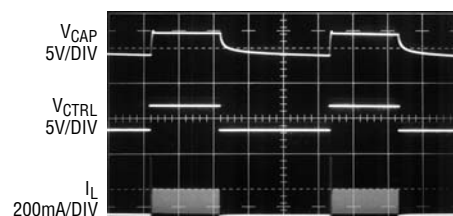

V_{IN} = 3.6V
FRONT PAGE
APPLICATION CIRCUIT

3491 G08

LT3491

TYPICAL PERFORMANCE CHARACTERISTICS ($T_A = 25^\circ\text{C}$ unless otherwise specified)

Quiescent Current ($V_{CTRL} = 3\text{V}$)

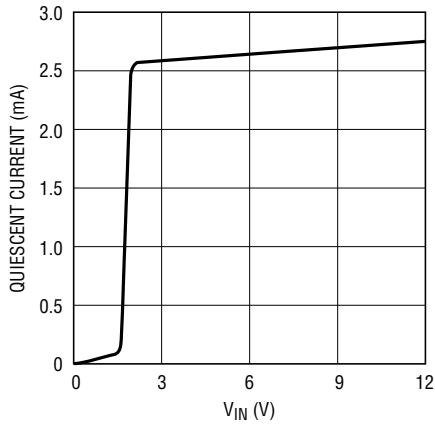

3491 G09

Switching Current Limit vs Duty Cycle

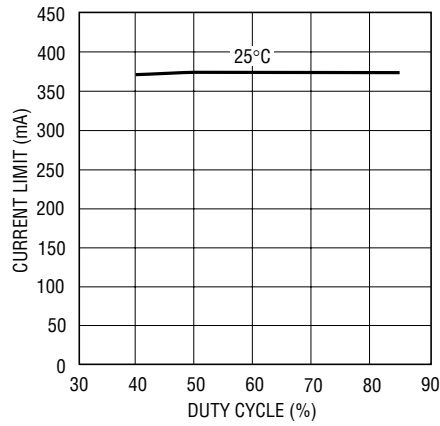

3491 G10

Schottky Leakage Current vs Temperature

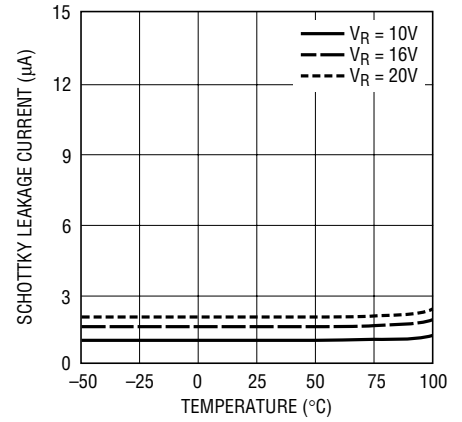

3491 G11

Open-Circuit Output Clamp Voltage vs Temperature

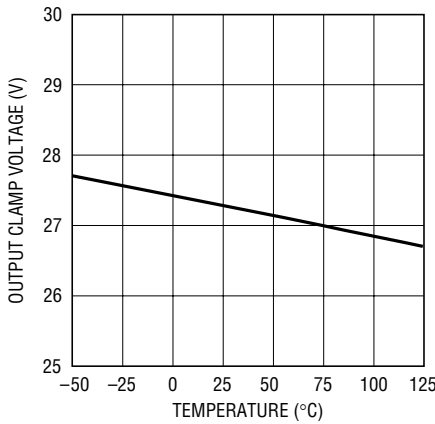

3491 G12

Input Current in Output Open Circuit vs Temperature

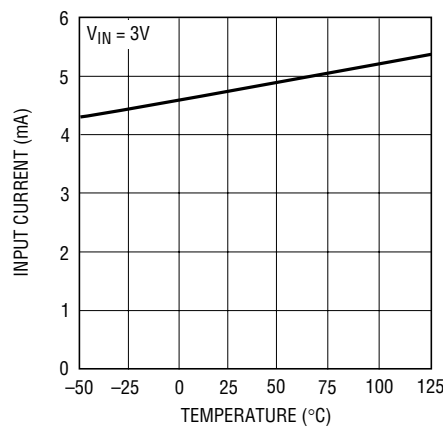

3491 G13

Switching Frequency vs Temperature

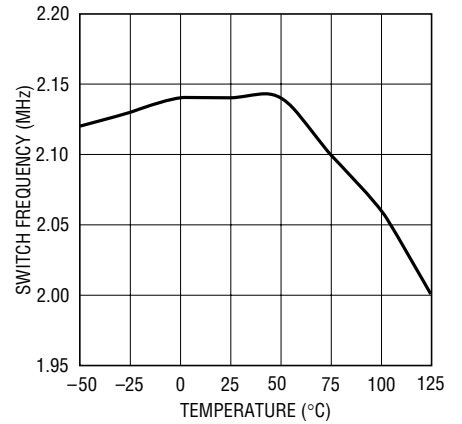

3419 G14

Sense Voltage ($V_{CAP} - V_{LED}$) vs V_{CTRL}

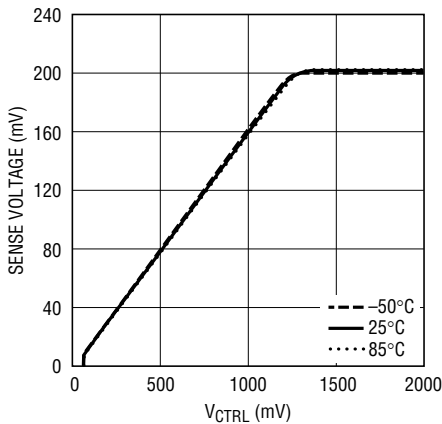

3491 G15

Sense Voltage ($V_{CAP} - V_{LED}$) vs V_{CAP}

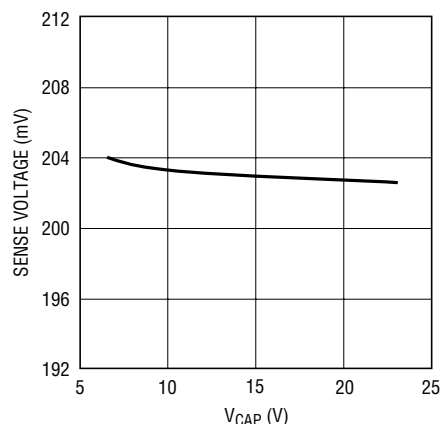

3491 G16

Sense Voltage ($V_{CAP} - V_{LED}$) vs Temperature

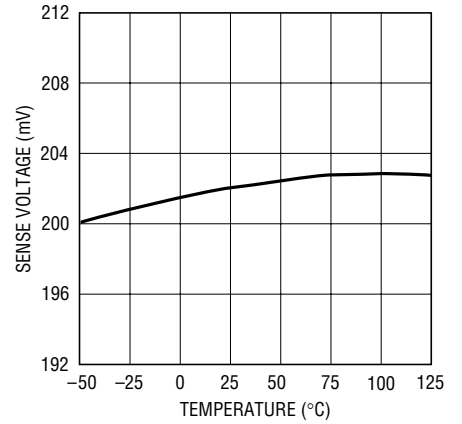

3491 G17

PIN FUNCTIONS (SC70/DFN)

SW (Pin 1/Pin 3): Switch Pin. Minimize trace area at this pin to minimize EMI. Connect the inductor at this pin.

GND (Pins 2, 3, 4/Pin 2): Ground Pins. All three pins should be tied directly to local ground plane.

V_{IN} (Pin 5/Pin 1): Input Supply Pin. Must be locally bypassed.

CTRL (Pin 6/Pin 6): Dimming and Shutdown Pin. Connect this pin below 50mV to disable the driver. As the pin voltage is ramped from 0V to 1.5V, the LED current ramps from 0 to I_{LED} (= 200mV/R_{SENSE}). The CTRL pin must not be left floating.

LED (Pin 7/Pin 5): Connection Point for the Anode of the First LED and the Sense Resistor. The LED current can be programmed by :

$$I_{LED} = \frac{200mV}{R_{SENSE}}$$

CAP (Pin 8/Pin 4): Output of the Driver. This pin is connected to the cathode of internal Schottky. Connect the output capacitor to this pin and the sense resistor from this pin to the LED pin.

EXPOSED PAD (NA/Pin 7): The Exposed Pad should be soldered to the PCB ground to achieve the rated thermal performance.

BLOCK DIAGRAM

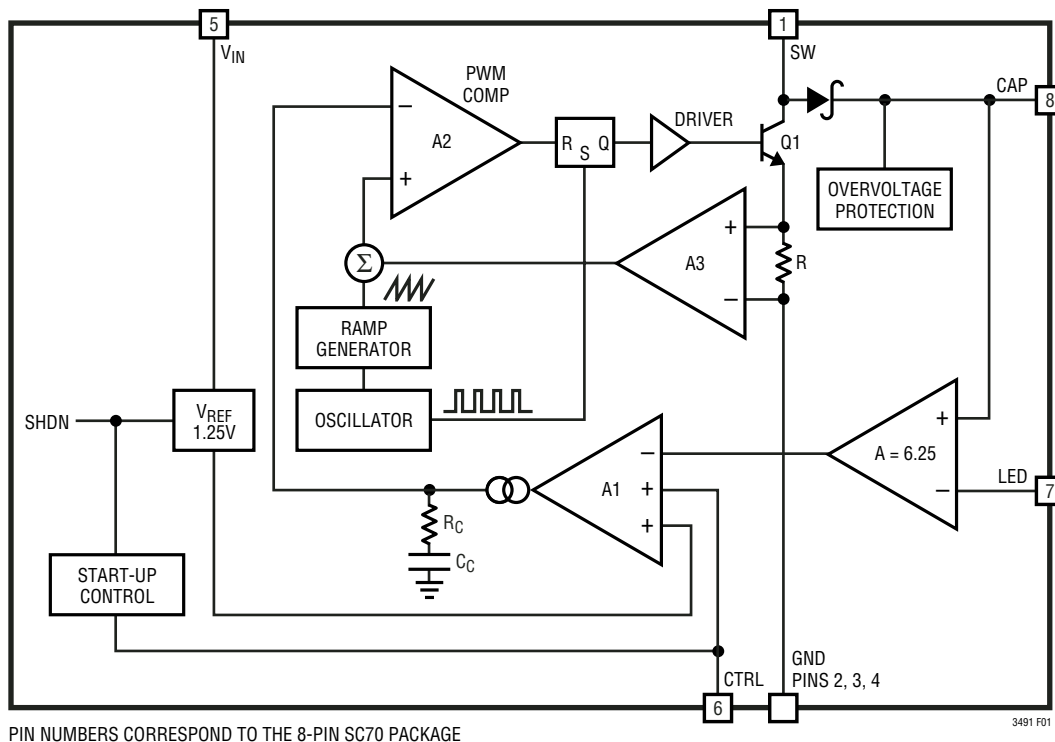

Figure 1. Block Diagram

OPERATION

The LT3491 uses a constant frequency, current mode control scheme to provide excellent line and load regulation. Operation can be best understood by referring to the Block Diagram in Figure 1.

At power up, the capacitor at the CAP pin is charged up to V_{IN} (input supply voltage) through the inductor and the internal Schottky diode. If CTRL is pulled higher than 100mV, the bandgap reference, the start-up bias and the oscillator are turned on. At the start of each oscillator cycle, the power switch Q1 is turned on. A voltage proportional to the switch current is added to a stabilizing ramp and the resulting sum is fed into the positive terminal of the PWM comparator, A2. When this voltage exceeds the level at the negative input of A2, the PWM logic turns off the power switch. The level at the negative input of A2 is set by the error amplifier A1, and is simply an amplified version of the difference between the V_{CAP} and V_{LED} voltage and the bandgap reference. In this manner the error amplifier, A1, sets the correct peak current level in inductor L1 to keep the output in regulation. The CTRL pin is used to adjust the LED current. The LT3491 enters into shutdown when CTRL is pulled lower than 50mV.

Minimum Output Current

The LT3491 can drive a 3-LED string at 2mA LED current without pulse skipping using the same external components shown in the application circuit on the front page of this data sheet. As current is further reduced, the device will begin skipping pulses. This will result in some low frequency ripple, although the average LED current remains regulated down to zero. The photo in Figure 2 details circuit operation driving three white LEDs at 2mA load. Peak inductor current is less than 60mA and the regulator operates in discontinuous mode, meaning the inductor current reaches zero during the discharge phase. After the inductor current reaches zero, the SW pin exhibits ringing due to the LC tank circuit formed by the inductor in combination with the switch and the diode capacitance. This ringing is not harmful; far less spectral energy is contained in the ringing than in the switch transitions.

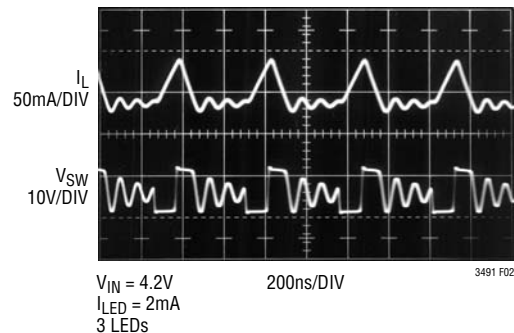

Figure 2. Switching Waveforms

APPLICATIONS INFORMATION

INDUCTOR SELECTION

A 10 μ H inductor is recommended for most LT3491 applications. Although small size and high efficiency are major concerns, the inductor should have low core losses at 2.3MHz and low DCR (copper wire resistance). Some small inductors in this category are listed in Table 1. The efficiency comparison of different inductors is shown in Figure 3.

Table 1. Recommended Inductors

PART	L (μ H)	DCR (Ω)	CURRENT RATING (mA)	VENDOR
LQH32CN100K53	10	0.3	450	Murata
LQH2MCN100K02	10	1.2	225	www.murata.com
SD3112-100	10	0.446	550	Cooper
www.cooperet.com				
1001AS-100M (TYPE D312C)	10	0.48	460	Toko
www.toko.com				
CDRH2D11	10	0.5375	280	Sumida
CDRH2D14	10	0.294	700	www.sumida.com

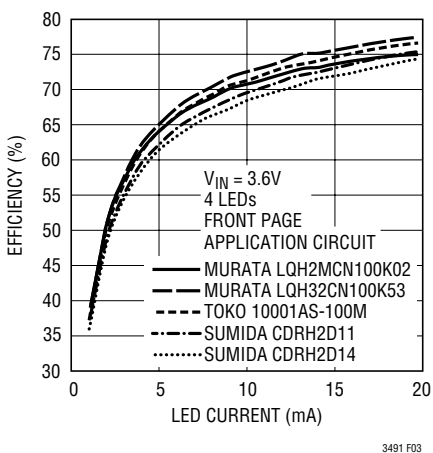

Figure 3. Efficiency Comparison of Different Inductors

CAPACITOR SELECTION

The small size of ceramic capacitors make them ideal for LT3491 applications. Use only X5R and X7R types because they retain their capacitance over wider temperature ranges than other types such as Y5V or Z5U. A 1 μ F input capacitor and a 1 μ F output capacitor are sufficient for most applications.

Table 2 shows a list of several ceramic capacitor manufacturers. Consult the manufacturers for detailed information on their entire selection of ceramic parts.

Table 2. Recommended Ceramic Capacitor Manufacturers

Taiyo Yuden	(800) 368-2496 www.t-yuden.com
AVX	(803) 448-9411 www.avxcorp.com
Murata	(714) 852-2001 www.murata.com

OVERVOLTAGE PROTECTION

The LT3491 has an internal open-circuit protection circuit. In the cases of output open circuit, when the LEDs are disconnected from the circuit or the LEDs fail open circuit, V_{CAP} is clamped at 27V (typ). The LT3491 will then switch at a very low frequency to minimize input current. The V_{CAP} and input current during output open circuit are shown in the Typical Performance Characteristics. Figure 4 shows the transient response when the LEDs are disconnected.

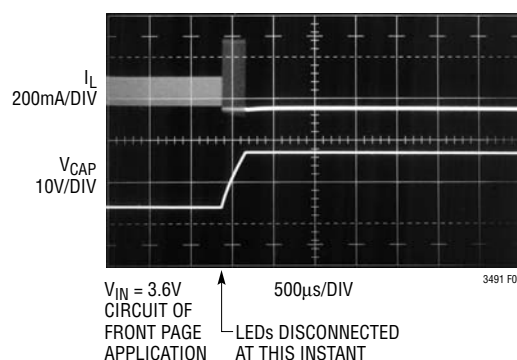

Figure 4. Output Open-Circuit Waveform

INRUSH CURRENT

The LT3491 has a built-in Schottky diode. When supply voltage is applied to the V_{IN} pin, an inrush current flows through the inductor and the Schottky diode and charges up the CAP voltage. The Schottky diode inside the LT3491 can sustain a maximum current of 1A.

APPLICATIONS INFORMATION

For low DCR inductors, which is usually the case for this application, the peak inrush current can be simplified as follows:

$$I_{PK} = \frac{V_{IN} - 0.6}{L \cdot \omega} \cdot \exp\left(-\frac{\alpha}{\omega} \cdot \frac{\pi}{2}\right)$$

$$\alpha = \frac{r}{2 \cdot L}$$

$$\omega = \sqrt{\frac{1}{L \cdot C} - \frac{r^2}{4 \cdot L^2}}$$

where L is the inductance, r is the DCR of the inductor and C is the output capacitance.

Table 3 gives inrush peak currents for some component selections.

Table 3. Inrush Peak Currents

V _{IN} (V)	r (Ω)	L (μH)	C _{OUT} (μF)	I _P (A)
4.2	0.3	10	1.0	1.06
4.2	1.2	10	1.0	0.86
4.2	0.58	15	1.0	0.83
4.2	1.6	15	1.0	0.68

PROGRAMMING LED CURRENT

The feedback resistor (R_{SENSE}) and the sense voltage (V_{CAP} - V_{LED}) control the LED current.

The CTRL pin controls the sense reference voltage as shown in the Typical Performance Characteristics. For CTRL higher than 1.5V, the sense reference is 200mV, which results in full LED current. In order to have accurate LED current, precision resistors are preferred (1% is recommended). The formula and table for R_{SENSE} selection are shown below.

$$R_{SENSE} = \frac{200mV}{I_{LED}}$$

Table 4. R_{SENSE} Value Selection for 200mV Sense

I _{LED} (mA)	R _{SENSE} (Ω)
5	40
10	20
15	13.3
20	10

DIMMING CONTROL

There are three different types of dimming control circuits. The LED current can be set by modulating the CTRL pin with a DC voltage, a filtered PWM signal or directly with a PWM signal.

Using a DC Voltage

For some applications, the preferred method of brightness control is a variable DC voltage to adjust the LED current. The CTRL pin voltage can be modulated to set the dimming of the LED string. As the voltage on the CTRL pin increases from 0V to 1.5V, the LED current increases from 0 to I_{LED}. As the CTRL pin voltage increases beyond 1.5V, it has no effect on the LED current.

The LED current can be set by:

$$I_{LED} \approx \frac{200mV}{R_{SENSE}}, \text{ when } V_{CTRL} > 1.5V$$

$$I_{LED} \approx \frac{V_{CTRL}}{6.25 \cdot R_{SENSE}}, \text{ when } V_{CTRL} < 1.25V$$

Feedback voltage variation versus control voltage is given in the Typical Performance Characteristics.

APPLICATIONS INFORMATION

Using a Filtered PWM Signal

A filtered PWM signal can be used to control the brightness of the LED string. The PWM signal is filtered (Figure 5) by a RC network and fed to the CTRL pin.

The corner frequency of R1, C1 should be much lower than the frequency of the PWM signal. R1 needs to be much smaller than the internal impedance of the CTRL pin which is 10MΩ (typ).

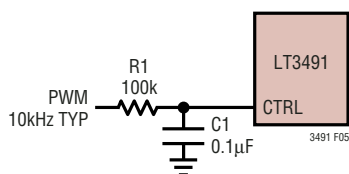

Figure 5. Dimming Control Using a Filtered PWM Signal

Direct PWM Dimming

Changing the forward current flowing in the LEDs not only changes the intensity of the LEDs, it also changes the color. The chromaticity of the LEDs changes with the change in forward current. Many applications cannot tolerate any shift in the color of the LEDs. Controlling the intensity of the LEDs with a direct PWM signal allows dimming of the LEDs without changing the color. In addition, direct PWM dimming offers a wider dimming range to the user.

Dimming the LEDs via a PWM signal essentially involves turning the LEDs on and off at the PWM frequency. The typical human eye has a limit of ~60 frames per second. By increasing the PWM frequency to ~80Hz or higher, the eye will interpret that the pulsed light source is continuously on. Additionally, by modulating the duty cycle (amount of “on-time”), the intensity of the LEDs can be controlled. The color of the LEDs remains unchanged in this scheme since the LED current value is either zero or a constant value.

Figure 6 shows a Li-Ion powered driver for four white LEDs. Direct PWM dimming method requires an external NMOS tied between the cathode of the lowest LED in the string and ground as shown in Figure 6. A simple logic

level Si2302 MOSFET can be used since its source is connected to ground. The PWM signal is applied to the CTRL pin of the LT3491 and the gate of the MOSFET. The PWM signal should traverse between 0V to 2.5V, to ensure proper turn on and off of the driver and the NMOS transistor Q1. When the PWM signal goes high, the LEDs are connected to ground and a current of $I_{LED} = 200\text{mV} / R_{SENSE}$ flows through the LEDs. When the PWM signal goes low, the LEDs are disconnected and turn off. The MOSFET ensures that the LEDs quickly turn off without discharging the output capacitor which in turn allows the LEDs to turn on faster. Figure 7 shows the PWM dimming waveforms for the circuit in Figure 6.

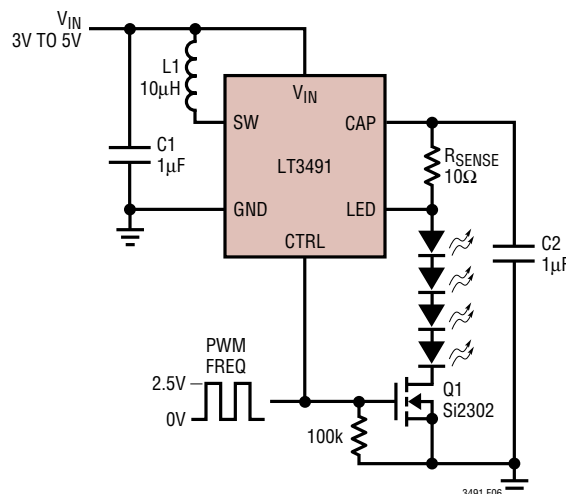

Figure 6. Li-Ion to Four White LEDs with Direct PWM Dimming

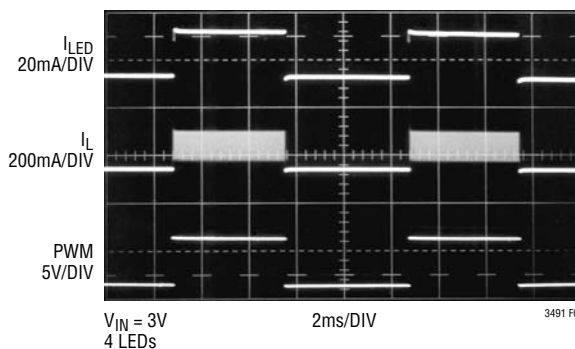

Figure 7. Direct PWM Dimming Waveforms

APPLICATIONS INFORMATION

The time it takes for the LED current to reach its programmed value sets the achievable dimming range for a given PWM frequency. For example, the settling time of the LED current in Figure 7 is approximately 30µs for a 3V input voltage. The achievable dimming range for this application and 100Hz PWM frequency can be determined using the following method.

Example:

$$f = 100\text{Hz}, t_{\text{SETTLE}} = 30\mu\text{s}$$

$$t_{\text{PERIOD}} = \frac{1}{f} = \frac{1}{100} = 0.01\text{s}$$

$$\text{Dim Range} = \frac{t_{\text{PERIOD}}}{t_{\text{SETTLE}}} = \frac{0.01\text{s}}{30\mu\text{s}} = 300:1$$

$$\text{Min Duty Cycle} = \frac{t_{\text{SETTLE}}}{t_{\text{PERIOD}}} \cdot 100 = \frac{30\mu\text{s}}{0.01\text{s}} \cdot 100 = 0.3\%$$

$$\text{Duty Cycle Range} = 100\% \rightarrow 0.3\% \text{ at } 100\text{Hz}$$

The calculations show that for a 100Hz signal the dimming range is 300 to 1. In addition, the minimum PWM duty cycle of 0.3% ensures that the LED current has enough time to settle to its final value. Figure 8 shows the dimming range achievable for three different frequencies with a settling time of 30µs.

The dimming range can be further extended by changing the amplitude of the PWM signal. The height of the PWM signal sets the commanded sense voltage across the sense resistor through the CTRL pin. In this manner both analog dimming and direct PWM dimming extend the dimming range for a given application. The color of the LEDs no longer remains constant because the forward current of the LED changes with the height of the CTRL signal. For the four LED application described above, the LEDs can be dimmed first, modulating the duty cycle of the PWM signal. Once the minimum duty cycle is reached, the height of the PWM signal can be decreased below 1.5V

down to 100mV. The use of both techniques together allows the average LED current for the four LED application to be varied from 20mA down to less than 20µA. Figure 9 shows the application for dimming using both analog dimming and PWM dimming. A potentiometer must be added to ensure that the gate of the NMOS receives a logic-level signal, while the CTRL signal can be adjusted to lower amplitudes.

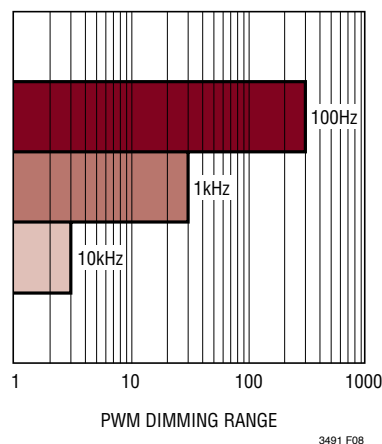

Figure 8. Dimming Range Comparison of Three PWM Frequencies

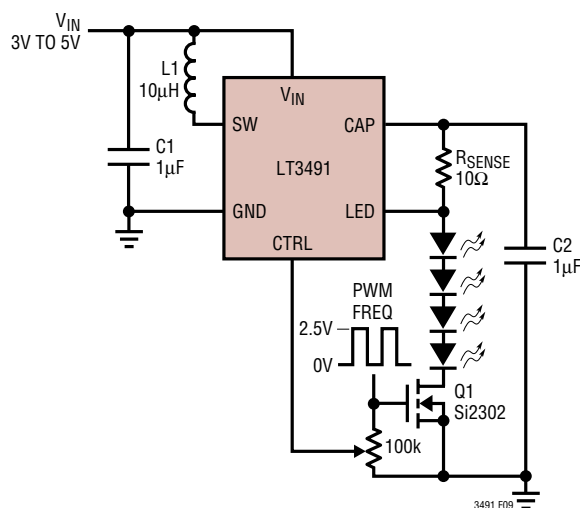

Figure 9. Li-Ion to Four White LEDs with Both PWM Dimming and Analog Dimming

APPLICATIONS INFORMATION

LOW INPUT VOLTAGE APPLICATIONS

The LT3491 can be used in low input voltage applications. The input supply voltage to the LT3491 must be 2.5V or higher. However, the inductor can be run off a lower battery voltage. This technique allows the LEDs to be powered off two alkaline cells. Most portable devices have a 3.3V logic supply voltage which can be used to power the LT3491. The LEDs can be driven straight from the battery, resulting in higher efficiency.

Figure 10 shows three LEDs powered by two AA cells. The battery is connected to the inductor and the chip is powered off a 3.3V logic supply voltage.

BOARD LAYOUT CONSIDERATIONS

As with all switching regulators, careful attention must be paid to the PCB board layout and component placement. To prevent electromagnetic interference (EMI) problems, proper layout of high frequency switching paths is essential. Minimize the length and area of all traces connected to the switching node pin (SW). Keep the sense voltage pins (CAP and LED) away from the switching node. Place C_{OUT} next to the CAP pin. Always use a ground plane under the switching regulator to minimize interplane coupling. Recommended component placement is shown in Figure 11.

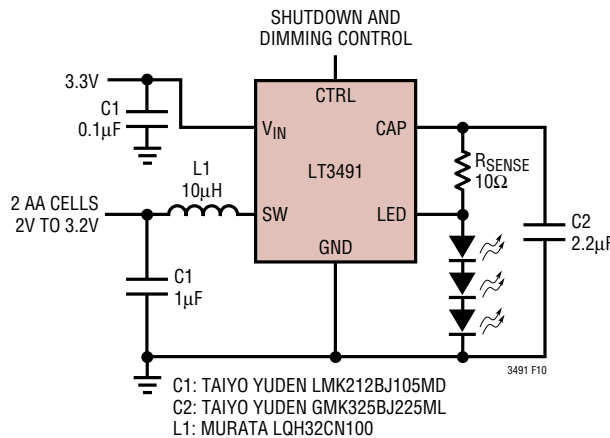

Figure 10. 2 AA Cells to Three White LEDs

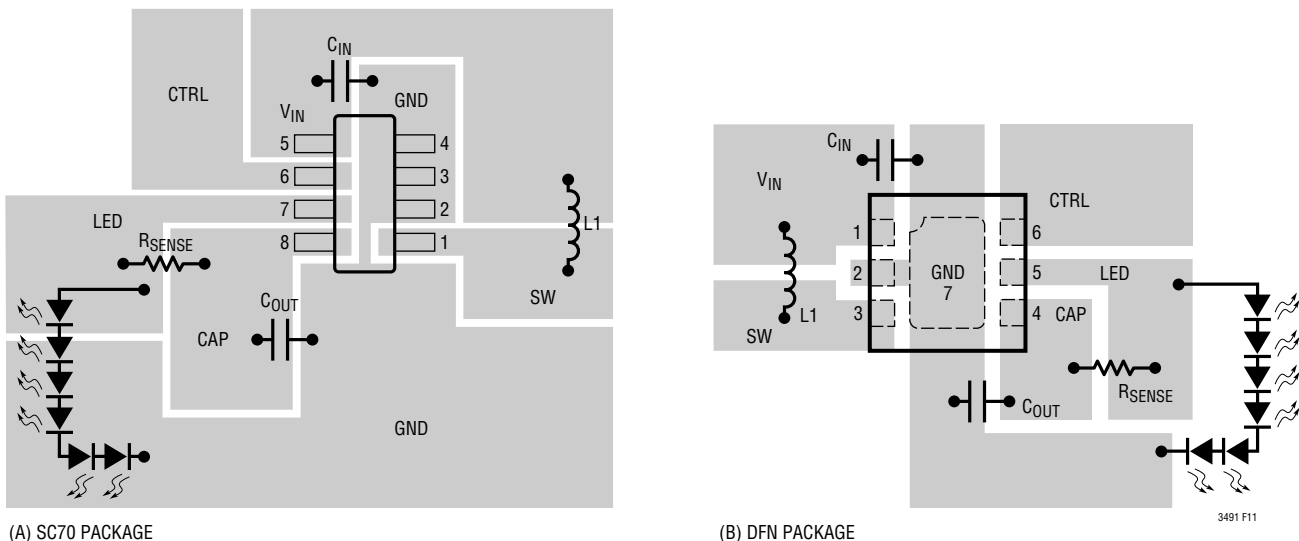
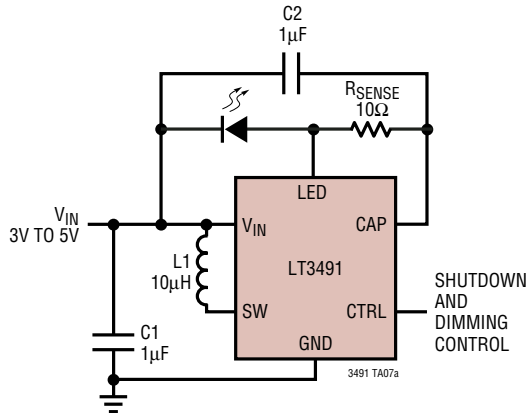

Figure 11. Recommended Component Placement

TYPICAL APPLICATIONS

Li-Ion Driver for One White LED



C1: TAIYO YUDEN LMK212BJ105MD
 C2: TAIYO YUDEN GMK316BJ105ML
 L1: MURATA LQH32CN100

Efficiency

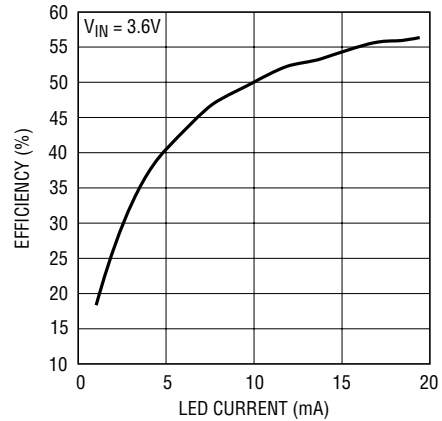

3491 TA07b

Li-Ion Driver for Two White LEDs

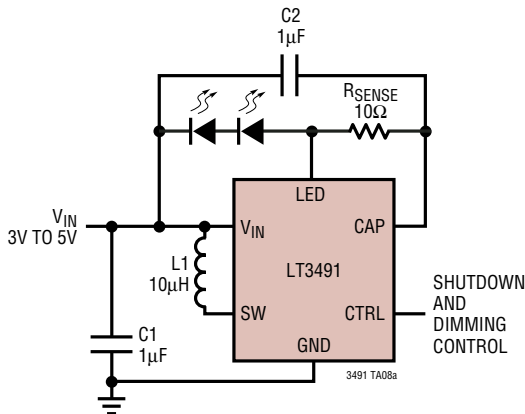

C1: TAIYO YUDEN LMK212BJ105MD
 C2: TAIYO YUDEN GMK316BJ105ML
 L1: MURATA LQH32CN100

Efficiency

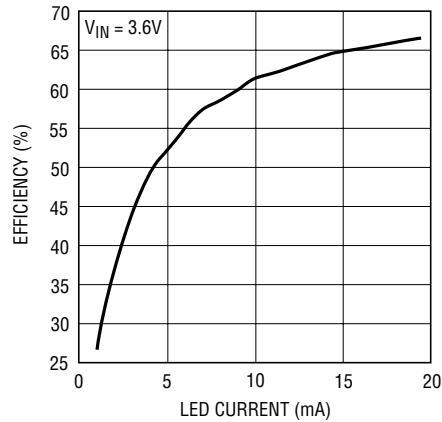

3491 TA08b

2-Cell Li-Ion Driver for Torch and Flash Mode LED Control

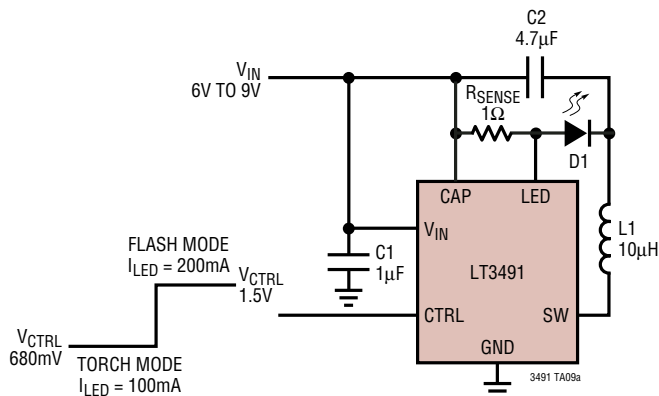

C1: TAIYO YUDEN LMK212BJ105MD
 C2: TAIYO YUDEN LMK212BJ475MG
 D1: AOT-2015 HPW1751B
 L1: MURATA LQH32CN100

Efficiency

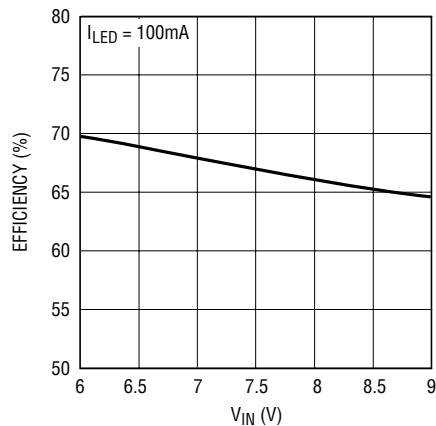

3491 TA09b

TYPICAL APPLICATIONS

12V to One White LED at 200mA

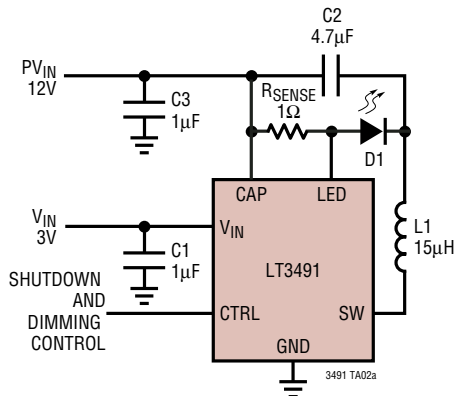

- C1, C3: TAIYO YUDEN LMK212BJ105MD
- C2: TAIYO YUDEN LMK316BJ475ML
- D1: LUXEON EMITTER LXHL-BW02
- L1: MURATA LQH32CN150

Efficiency

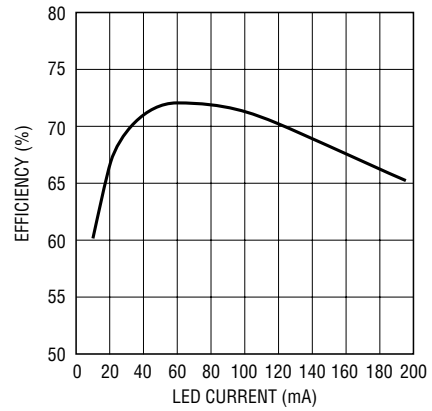

3491 TA02b

12V to Two White LEDs at 200mA

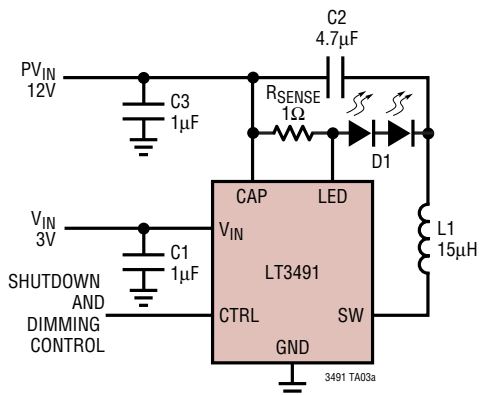

- C1, C3: TAIYO YUDEN LMK212BJ105MD
- C2: TAIYO YUDEN LMK316BJ475ML
- D1: LUXEON EMITTER LXHL-BW02
- L1: MURATA LQH32CN150

Efficiency

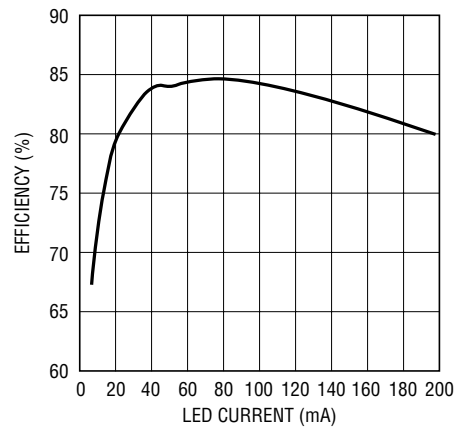

3491 TA03b

TYPICAL APPLICATIONS

Li-Ion Driver for Three White LEDs

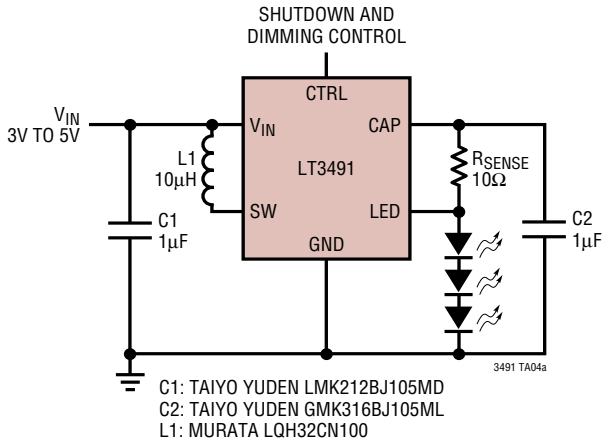

Efficiency

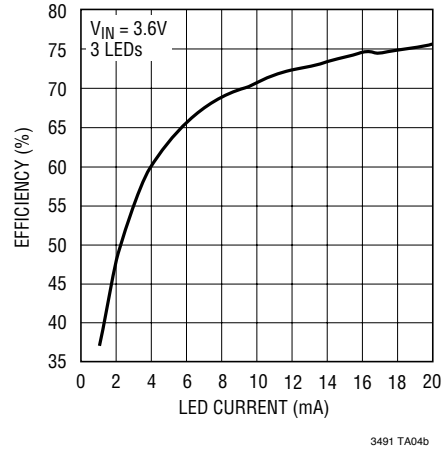

Li-Ion Driver for Five White LEDs

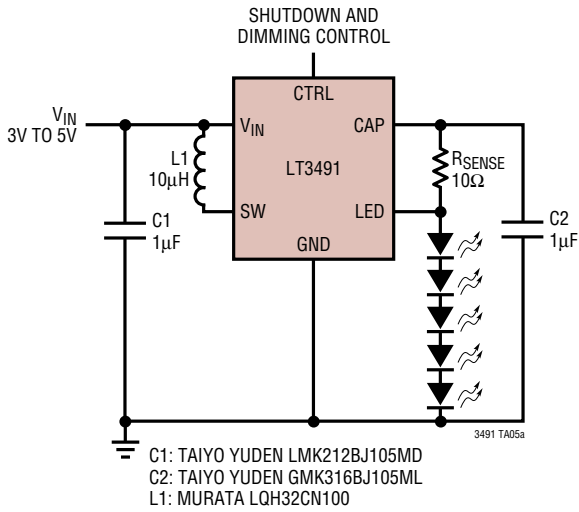

Efficiency

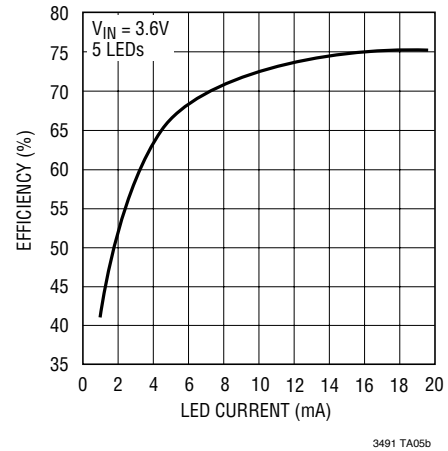

PACKAGE DESCRIPTION

SC8 Package 8-Lead Plastic SC70 (Reference LTC DWG # 05-08-1639 Rev 0)

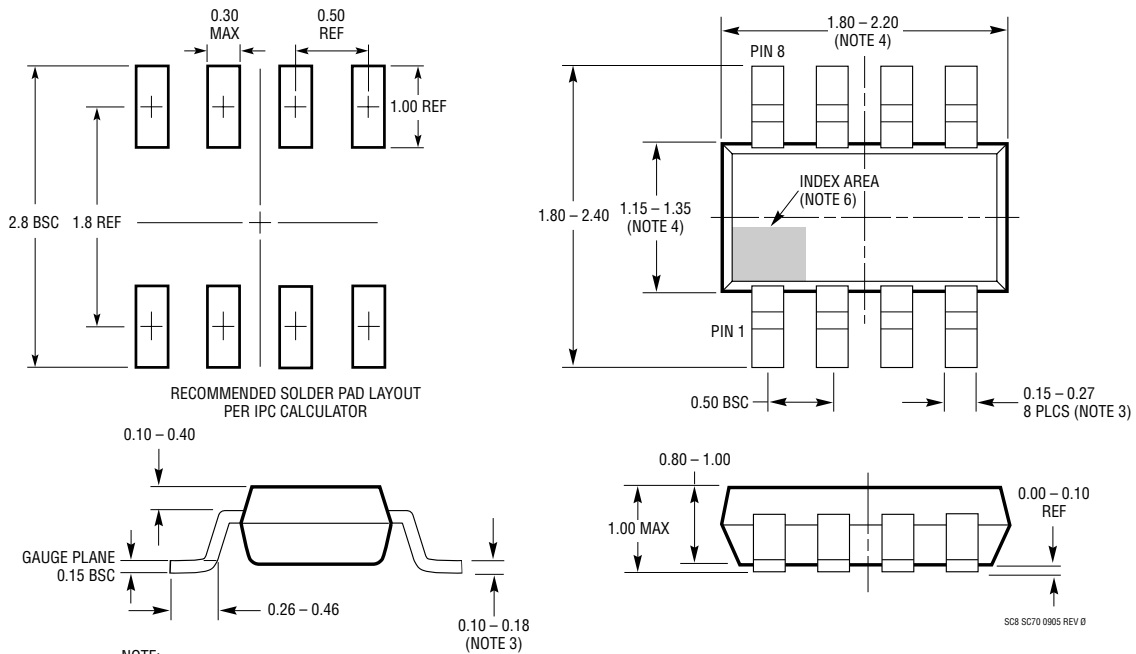

- NOTE:
1. DIMENSIONS ARE IN MILLIMETERS
 2. DRAWING NOT TO SCALE
 3. DIMENSIONS ARE INCLUSIVE OF PLATING
 4. DIMENSIONS ARE EXCLUSIVE OF MOLD FLASH AND METAL BURR
 5. MOLD FLASH SHALL NOT EXCEED 0.254mm
 6. DETAILS OF THE PIN 1 IDENTIFIER ARE OPTIONAL, BUT MUST BE LOCATED WITHIN THE INDEX AREA
 7. EIAJ PACKAGE REFERENCE IS EIAJ SC-70 AND JEDEC MO-203 VARIATION BA

DC Package 6-Lead DFN (2mm x 2mm) (Reference LTC DWG # 05-08-1703)

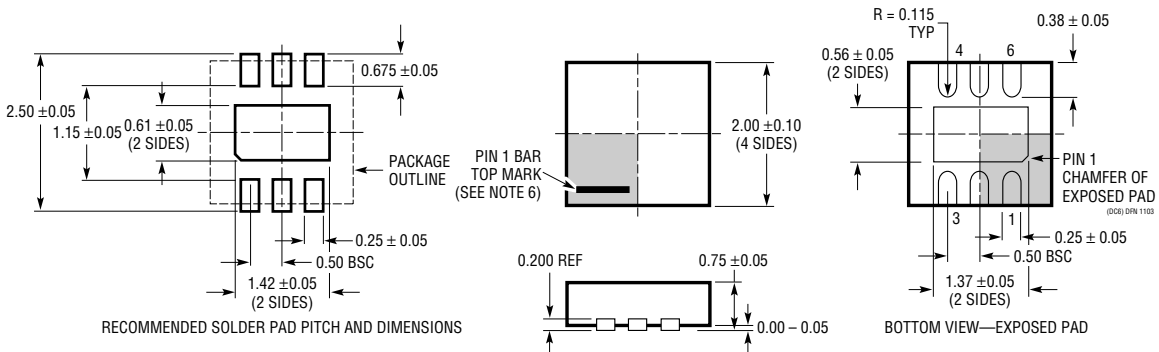

- NOTE:
1. DRAWING TO BE MADE A JEDEC PACKAGE OUTLINE MO-229 VARIATION OF (WCCD-2)
 2. DRAWING NOT TO SCALE
 3. ALL DIMENSIONS ARE IN MILLIMETERS
 4. DIMENSIONS OF EXPOSED PAD ON BOTTOM OF PACKAGE DO NOT INCLUDE MOLD FLASH. MOLD FLASH, IF PRESENT, SHALL NOT EXCEED 0.15mm ON ANY SIDE
 5. EXPOSED PAD SHALL BE SOLDER PLATED
 6. SHADED AREA IS ONLY A REFERENCE FOR PIN 1 LOCATION ON THE TOP AND BOTTOM OF PACKAGE

LT3491

TYPICAL APPLICATION

Li-Ion Driver for Six White LEDs

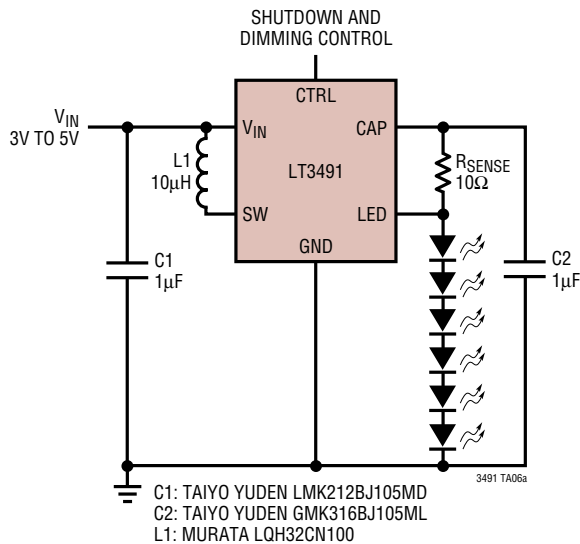

Efficiency

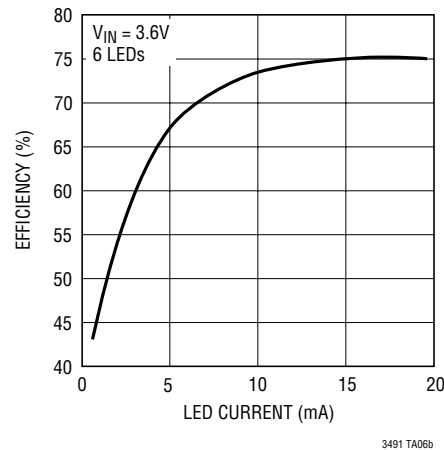

RELATED PARTS

PART NUMBER	DESCRIPTION	COMMENTS
LT1618	Constant Current, Constant Voltage 1.24MHz, High Efficiency Boost Regulator	Up to 16 White LEDs, V_{IN} : 1.6V to 18V, $V_{OUT(MAX)}$ = 34V, I_Q = 1.8mA, I_{SD} < 1µA, MS Package
LT1932	Constant Current, 1.2MHz, High Efficiency White LED Boost Regulator	Up to 8 White LEDs, V_{IN} : 1V to 10V, $V_{OUT(MAX)}$ = 34V, I_Q = 1.2mA, I_{SD} < 1µA, ThinSOT™ Package
LT1937	Constant Current, 1.2MHz, High Efficiency White LED Boost Regulator	Up to 4 White LEDs, V_{IN} : 2.5V to 10V, $V_{OUT(MAX)}$ = 34V, I_Q = 1.9mA, I_{SD} < 1µA, ThinSOT/SC70 Packages
LTC®3200	Low Noise, 2MHz Regulated Charge Pump White LED Driver	Up to 6 White LEDs, V_{IN} : 2.7V to 4.5V, I_Q = 8mA, I_{SD} < 1µA, MS Package
LTC3200-5	Low Noise, 2MHz Regulated Charge Pump White LED Driver	Up to 6 White LEDs, V_{IN} : 2.7V to 4.5V, I_Q = 8mA, I_{SD} < 1µA, ThinSOT Package
LTC3201	Low Noise, 1.7MHz Regulated Charge Pump White LED Driver	Up to 6 White LEDs, V_{IN} : 2.7V to 4.5V, I_Q = 6.5mA, I_{SD} < 1µA, MS Package
LTC3202	Low Noise, 1.5MHz Regulated Charge Pump White LED Driver	Up to 8 White LEDs, V_{IN} : 2.7V to 4.5V, I_Q = 5mA, I_{SD} < 1µA, MS Package
LTC3205	High Efficiency, Multidisplay LED Controller	Up to 4 (Main), 2 (Sub) and RGB, V_{IN} : 2.8V to 4.5V, I_Q = 50µA, I_{SD} < 1µA, 24-Lead QFN Package
LT3465/LT3465A	Constant Current, 1.2MHz/2.7MHz, High Efficiency White LED Boost Regulator with Integrated Schottky Diode	Up to 6 White LEDs, V_{IN} : 2.7V to 16V, $V_{OUT(MAX)}$ = 34V, I_Q = 1.9mA, I_{SD} < 1µA, ThinSOT Package
LT3466/LT3466-1	Dual Full Function, 2MHz Diodes White LED Step-Up Converter with Built-In Schottkys	Up to 20 White LEDs, V_{IN} : 2.7V to 24V, $V_{OUT(MAX)}$ = 39V, DFN, TSSOP-16 Packages
LT3486	Dual 1.3A White LED Converter with 1000:1 True Color PWM Dimming	Drives Up to 16 100mA White LEDs. V_{IN} : 2.5V to 24V, $V_{OUT(MAX)}$ = 36V, DFN, TSSOP Packages

ThinSOT is a trademark of Linear Technology Corporation.