

Inchange Semiconductor

Product Specification

Silicon NPN Power Transistors

2N6676 2N6677 2N6678

DESCRIPTION

- With TO-3 package
- High voltage capability
- Fast switching speeds
- Low saturation voltage

APPLICATIONS

Designed for high voltage switching applications such as :

- Off-line power supplies
- Converter circuits
- Pulse width modulated regulators

PINNING (See Fig.2)

PIN	DESCRIPTION
1	Base
2	Emitter
3	Collector



Absolute maximum ratings(Ta=)

SYMBOL	PARAMETER	CONDITIONS	VALUE	UNIT	
V _{CBO}	Collector-base voltage	Open emitter	2N6676	450	V
			2N6677	550	
			2N6678	650	
V _{CEO}	Collector-emitter voltage	Open base	2N6676	300	V
			2N6677	350	
			2N6678	400	
V _{EBO}	Emitter-base voltage	Open collector	8	V	
I _C	Collector current		15	A	
I _{CM}	Collector current-peak		20	A	
I _B	Base current		5	A	
P _T	Total power dissipation	T _c =25	175	W	
T _j	Junction temperature		200		
T _{stg}	Storage temperature		-65~200		

Silicon NPN Power Transistors

2N6676 2N6677 2N6678

CHARACTERISTICS

T_j=25 unless otherwise specified

SYMBOL	PARAMETER	CONDITIONS	MIN	TYP.	MAX	UNIT
V _{CEQ(SUS)}	Collector-emitter sustaining voltage	2N6676	I _C =0.2A ; I _B =0			V
		2N6677				
		2N6678				
V _{CEsat}	Collector-emitter saturation voltage	I _C =15A; I _B =3A			1.5	V
V _{BEsat}	Base-emitter saturation voltage	I _C =15A; I _B =3A			1.5	V
I _{CEV}	Collector cut-off current	V _{CE} =RatedV _{CEV} ; V _{BE(off)} =-1.5V T _C =100			0.1 1.0	mA
I _{EBO}	Emitter cut-off current	V _{EB} =8V; I _C =0			2.0	mA
h _{FE-1}	DC current gain	I _C =1A ; V _{CE} =5V	15		50	
h _{FE-2}	DC current gain	I _C =15A ; V _{CE} =3V	8			
C _{OB}	Output capacitance	I _E =0 ; V _{CB} =10V; f=0.1MHz			500	pF
f _T	Transition frequency	I _C =1A ; V _{CE} =10V; f=5.0MHz	3			MHz

Switching times

t _d	Delay time	I _C =15A; I _{B1} =-I _{B2} =3.0A V _{CC} =200V; t _p =20 μs; Duty Cycle 2.0% V _{BB} =6V, R _L =1.35			0.2	μs
t _r	Rise time				0.6	μs
t _s	Storage time				2.5	μs
t _f	Fall time				0.6	μs

THERMAL CHARACTERISTICS

SYMBOL	PARAMETER	MAX	UNIT
R _{th j-c}	Thermal resistance from junction to case	1.0	/W

Silicon NPN Power Transistors

2N6676 2N6677 2N6678

PACKAGE OUTLINE

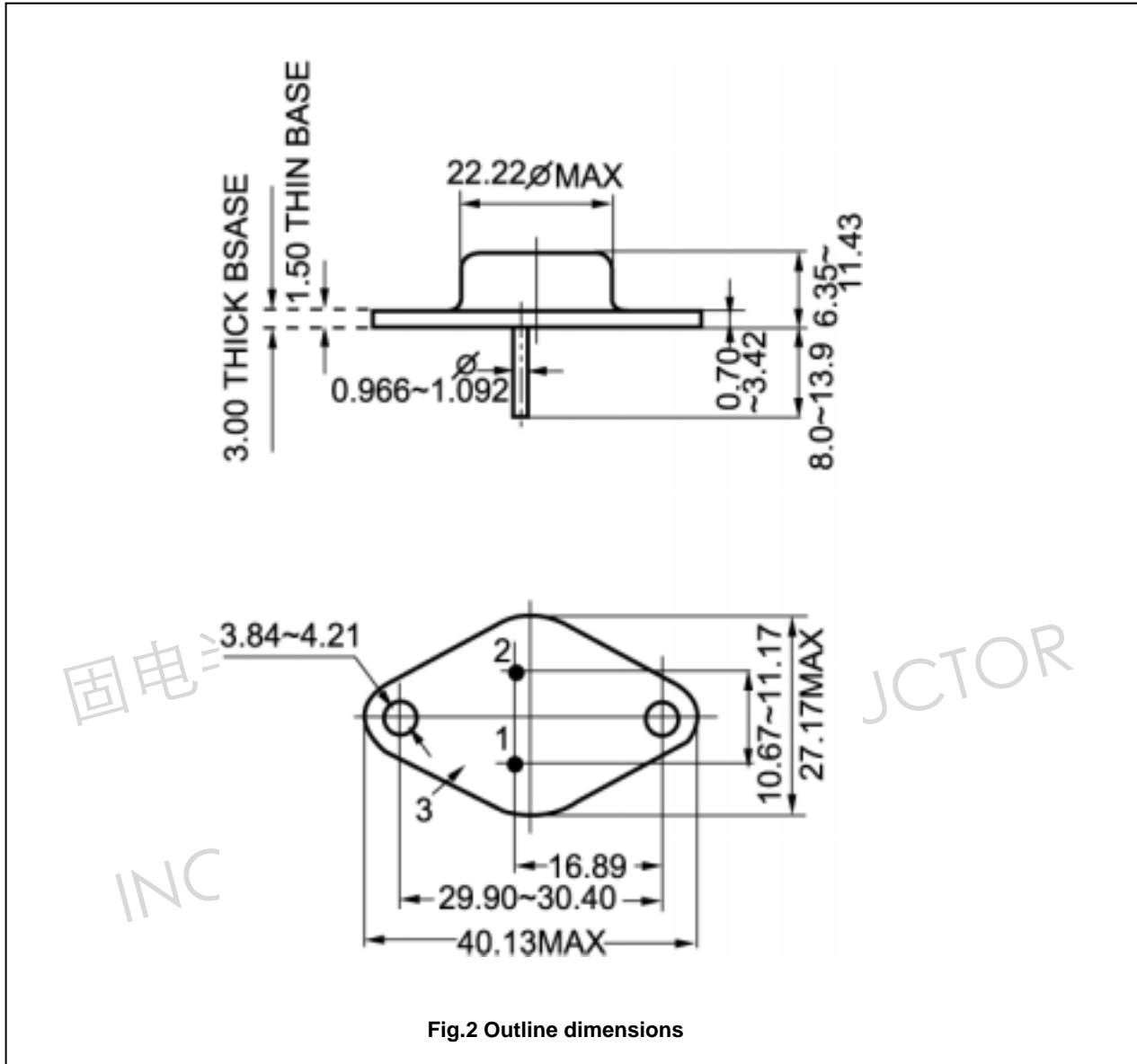

Fig.2 Outline dimensions