

Inchange Semiconductor

Product Specification

Silicon PNP Power Transistors

2SB1034

DESCRIPTION

- With TO-126 package
- Low collector saturation voltage
- High DC current gain
- DARLINGTON

APPLICATIONS

- For power amplifier applications

PINNING

PIN	DESCRIPTION
1	Emitter
2	Collector;connected to mounting base
3	Base

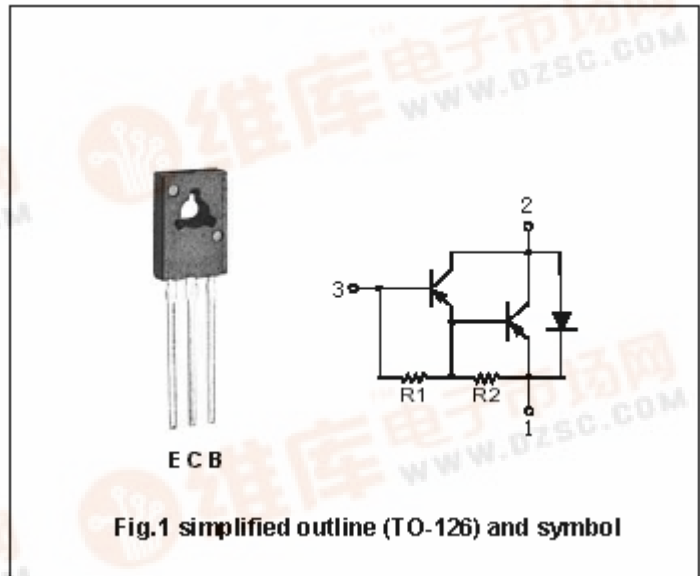

Absolute maximum ratings(Ta=25)

SYMBOL	PARAMETER	CONDITIONS	VALUE	UNIT
V _{CBO}	Collector-base voltage	Open emitter	-80	V
V _{CEO}	Collector-emitter voltage	Open base	-80	V
V _{EBO}	Emitter-base voltage	Open collector	-8	V
I _C	Collector current (DC)		-2	A
I _B	Base current (DC)		-0.5	A
P _C	Total power dissipation	T _C =25	15	W
T _j	Junction temperature		150	
T _{stg}	Storage temperature		-55~150	

Silicon PNP Power Transistors

2SB1034

CHARACTERISTICS

T_j=25 unless otherwise specified

SYMBOL	PARAMETER	CONDITIONS	MIN	TYP.	MAX	UNIT
V _{(BR)CEO}	Collector-emitter breakdown voltage	I _C =-10mA ; I _B =0	-80			V
V _{CEsat}	Collector-emitter saturation voltage	I _C =-1A ; I _B =-1mA			-1.5	V
V _{BEsat}	Base-emitter saturation voltage	I _C =-1A ; I _B =-1mA			-2.0	V
I _{CBO}	Collector cut-off current	V _{CB} =-80V; I _E =0			-10	μA
I _{EBO}	Emitter cut-off current	V _{EB} =-8V; I _C =0			-4	mA
h _{FE}	DC current gain	I _C =-1A ; V _{CE} =-2V	2000			
C _{OB}	Output capacitance	I _E =0; V _{CB} =-10V; f=1MHz		30		pF
f _T	Transition frequency	I _C =-0.5A ; V _{CE} =-2V		50		MHz
Switching times						
t _{on}	Turn-on time	R _L =30 I _{B1} =I _{B2} =1mA V _{CC} =-30V		0.4		μs
t _s	Storage time			2.0		μs
t _f	Fall time			0.4		μs

PACKAGE OUTLINE

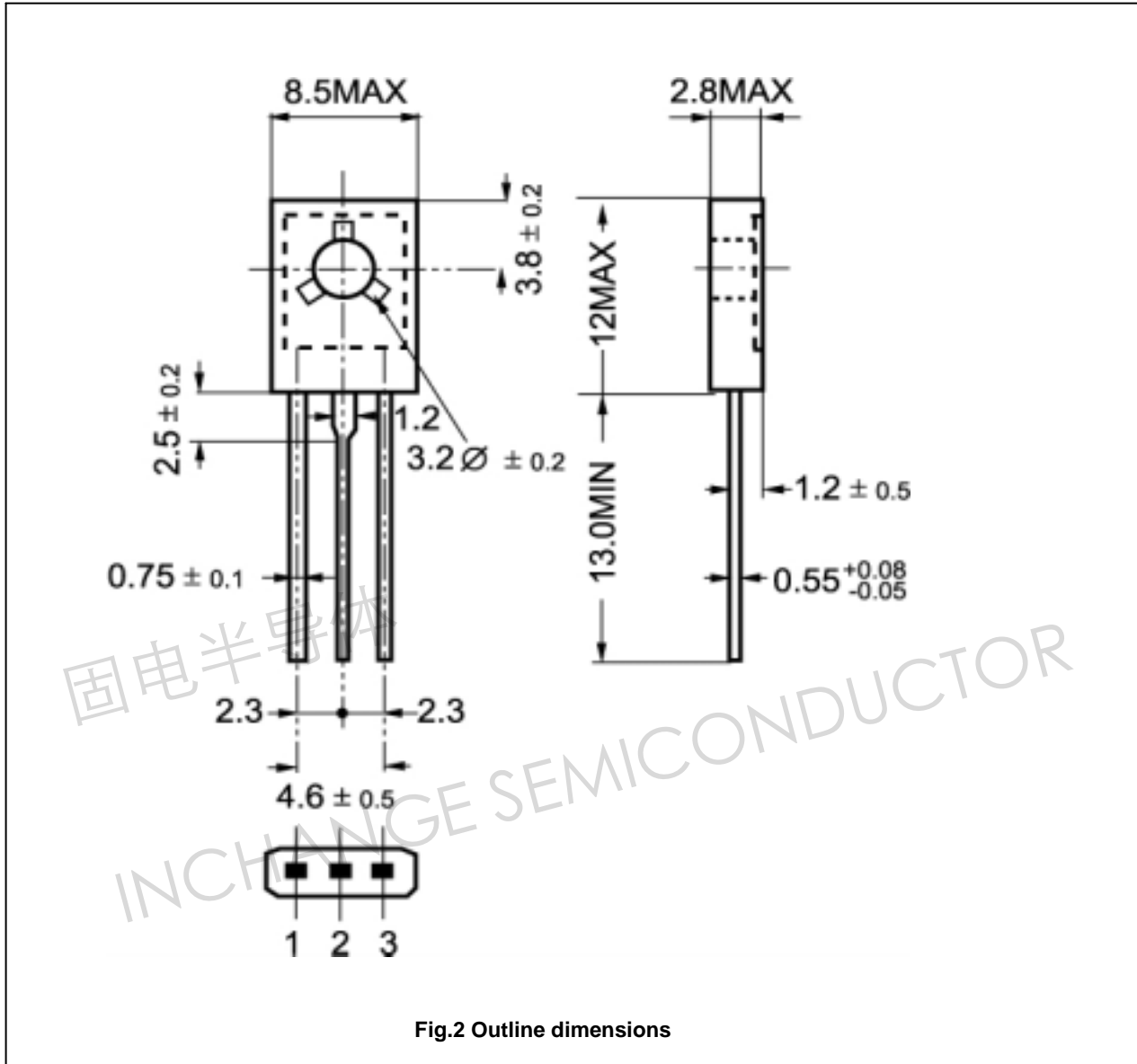

Fig.2 Outline dimensions