

Silicon PNP Power Transistors

2SB827

DESCRIPTION

- With TO-3PN package
- Complement to type 2SD1063
- Wide area of safe operation
- Low collector-emitter saturation voltage :  
 $V_{CE(sat)} = (-)0.4V$  max.

APPLICATIONS

- Universal high current switching as solenoid driving, high speed inverter and converter.

PINNING

PIN	DESCRIPTION
1	Base
2	Collector; connected to mounting base
3	Emitter

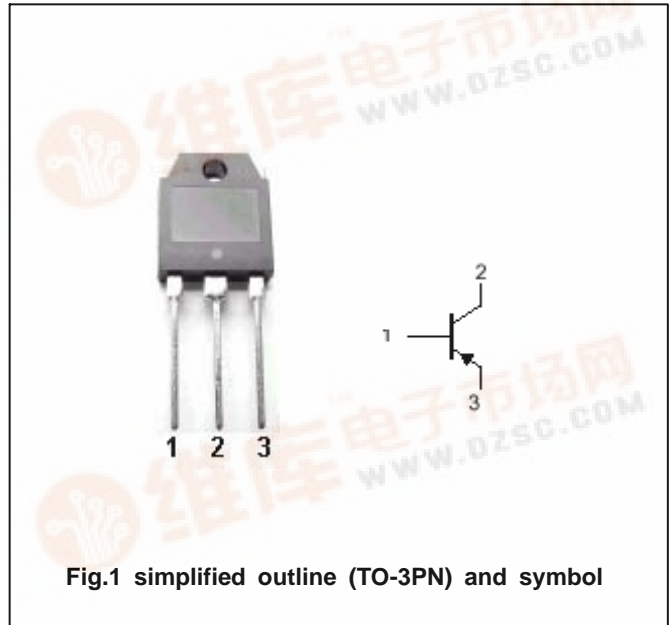

Fig.1 simplified outline (TO-3PN) and symbol

Absolute maximum ratings(Tc=25 )

SYMBOL	PARAMETER	CONDITIONS	VALUE	UNIT
$V_{CBO}$	Collector-base voltage	Open emitter	-60	V
$V_{CEO}$	Collector-emitter voltage	Open base	-50	V
$V_{EBO}$	Emitter-base voltage	Open collector	-6	V
$I_C$	Collector current (DC)		-7	A
$I_{CP}$	Collector current (Pulse)		-14	A
$P_C$	Collector power dissipation	$T_C=25$	60	W
$T_j$	Junction temperature		150	
$T_{stg}$	Storage temperature		-55~150	

## Silicon PNP Power Transistors

## 2SB827

## CHARACTERISTICS

T<sub>j</sub>=25 unless otherwise specified

SYMBOL	PARAMETER	CONDITIONS	MIN	TYP.	MAX	UNIT
V <sub>(BR)CEO</sub>	Collector-emitter breakdown voltage	I <sub>C</sub> =-1mA ; R <sub>BE</sub> =∞	-50			V
V <sub>(BR)CBO</sub>	Collector-base breakdown voltage	I <sub>C</sub> =-1mA ; I <sub>E</sub> =0	-60			V
V <sub>(BR)EBO</sub>	Emitter-base breakdown voltage	I <sub>E</sub> =-1mA ; I <sub>C</sub> =0	-6			V
V <sub>CEsat</sub>	Collector-emitter saturation voltage	I <sub>C</sub> =-4A ; I <sub>B</sub> =-0.4A			-0.4	V
I <sub>CBO</sub>	Collector cut-off current	V <sub>CB</sub> =-40V ; I <sub>E</sub> =0			-0.1	mA
I <sub>EBO</sub>	Emitter cut-off current	V <sub>EB</sub> =-4V ; I <sub>C</sub> =0			-0.1	mA
h <sub>FE-1</sub>	DC current gain	I <sub>C</sub> =-1A ; V <sub>CE</sub> =-2V	70		280	
h <sub>FE-2</sub>	DC current gain	I <sub>C</sub> =-5A ; V <sub>CE</sub> =-2V	30			
f <sub>T</sub>	Transition frequency	I <sub>C</sub> =-1A ; V <sub>CE</sub> =-5V		10		MHz

## Switching times

t <sub>on</sub>	Turn-on time			0.20		μs
t <sub>stg</sub>	Storage time	I <sub>C</sub> =-2.0A ; I <sub>B1</sub> =-I <sub>B2</sub> =-0.2A V <sub>CC</sub> =-20V ; R <sub>L</sub> =10		0.70		μs
t <sub>f</sub>	Fall time			0.10		μs

◆ h<sub>FE-1</sub> Classifications

Q	R	S
70-140	100-200	140-280

Silicon PNP Power Transistors

2SB827

PACKAGE OUTLINE

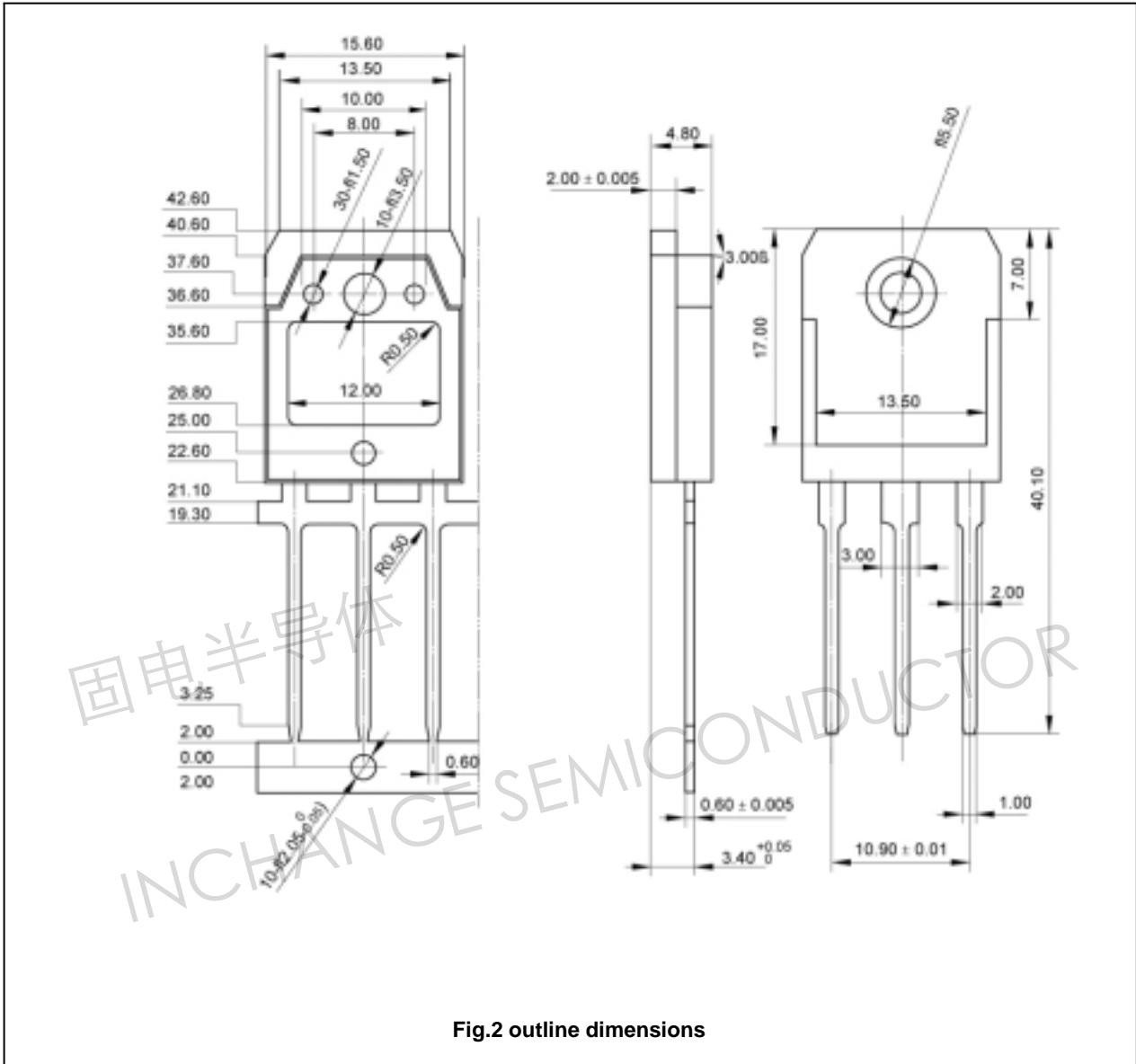

Silicon PNP Power Transistors

2SB827

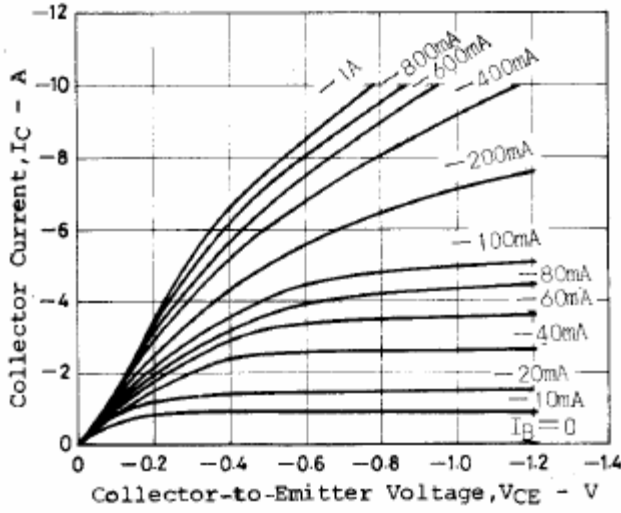

Fig.3 Static Characteristic

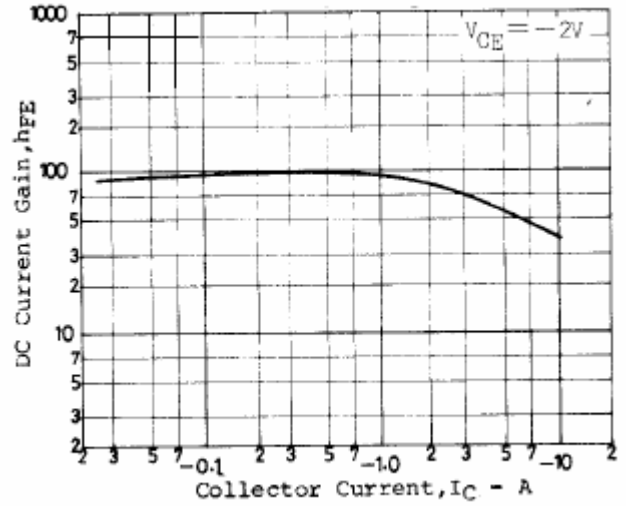

Fig.4 DC current Gain

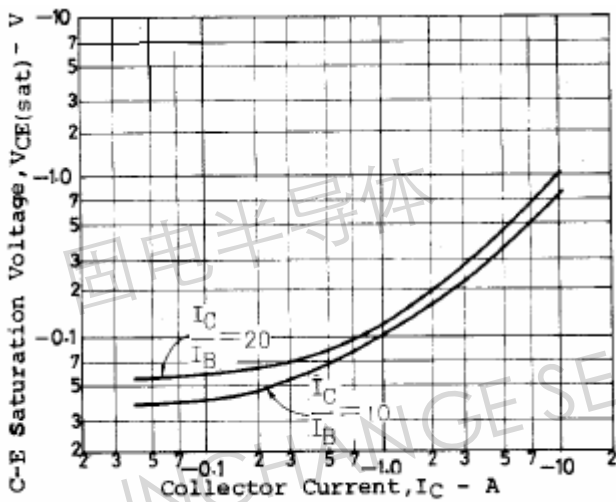

Fig.5 Collector-Emitter Saturation Voltage

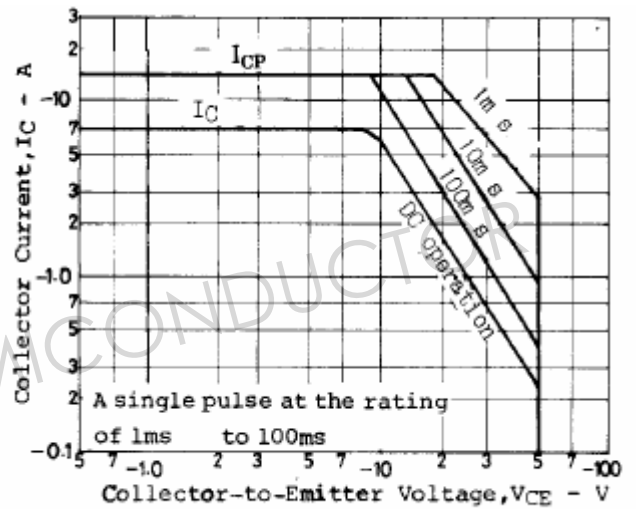

Fig.6 Safe Operating Area