

Inchange Semiconductor

Product Specification

Silicon PNP Power Transistors

2SB859

DESCRIPTION

- With TO-220C package
- Complement to type 2SD1135

APPLICATIONS

- Low frequency power amplifier

PINNING

PIN	DESCRIPTION
1	Emitter
2	Collector;connected to mounting base
3	Base

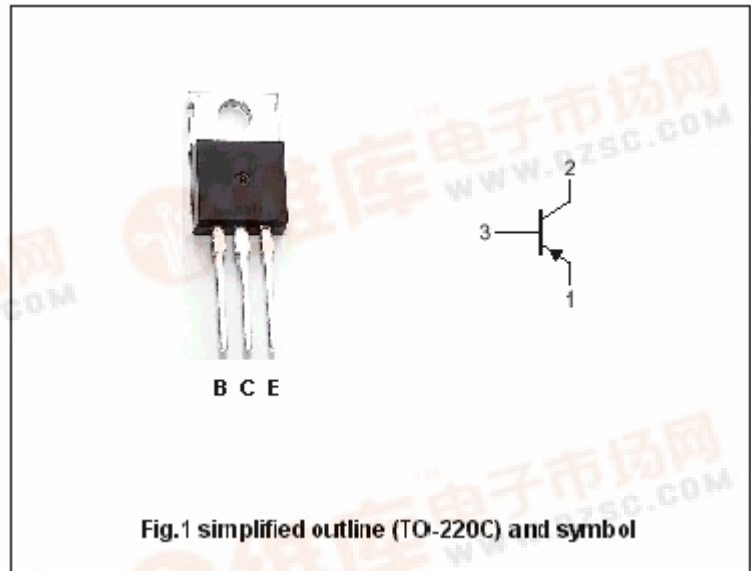

Absolute maximum ratings(Tc=25)

SYMBOL	PARAMETER	CONDITIONS	VALUE	UNIT
V _{CBO}	Collector-base voltage	Open emitter	-100	V
V _{CEO}	Collector-emitter voltage	Open base	-80	V
V _{EBO}	Emitter-base voltage	Open collector	-5	V
I _C	Collector current		-4	A
I _{CP}	Collector current-Peak		-8	A
P _C	Collector power dissipation	T _C =25	40	W
T _j	Junction temperature		150	
T _{stg}	Storage temperature		-45~150	

Silicon PNP Power Transistors

2SB859

CHARACTERISTICS

T_j=25 unless otherwise specified

SYMBOL	PARAMETER	CONDITIONS	MIN	TYP.	MAX	UNIT
V _{(BR)CEO}	Collector-emitter breakdown voltage	I _C =-50mA; R _{BE} =	-80			V
V _{(BR)EBO}	Emitter-base breakdown voltage	I _E =-10 μ A; I _C =0	-5			V
V _{CEsat}	Collector-emitter saturation voltage	I _C =-2 A; I _B =-0.2 A			-2.0	V
V _{BE}	Base-emitter voltage	I _C =-1 A; V _{CE} =-5V			-1.5	V
I _{CBO}	Collector cut-off current	V _{CB} =-80V; I _E =0			-0.1	mA
h _{FE-1}	DC current gain	I _C =-1 A; V _{CE} =-5V	60		200	
h _{FE-2}	DC current gain	I _C =-0.1A; V _{CE} =-5V	35			
C _{ob}	Collector output capacitance	I _C =0; V _{CB} =-20V; f=1MHz		75		pF
f _T	Transition frequency	I _C =-0.5A; V _{CE} =-5V		20		MHz

◆ h_{FE-1} classifications

B	C
60-120	100-200

Silicon PNP Power Transistors

2SB859

PACKAGE OUTLINE

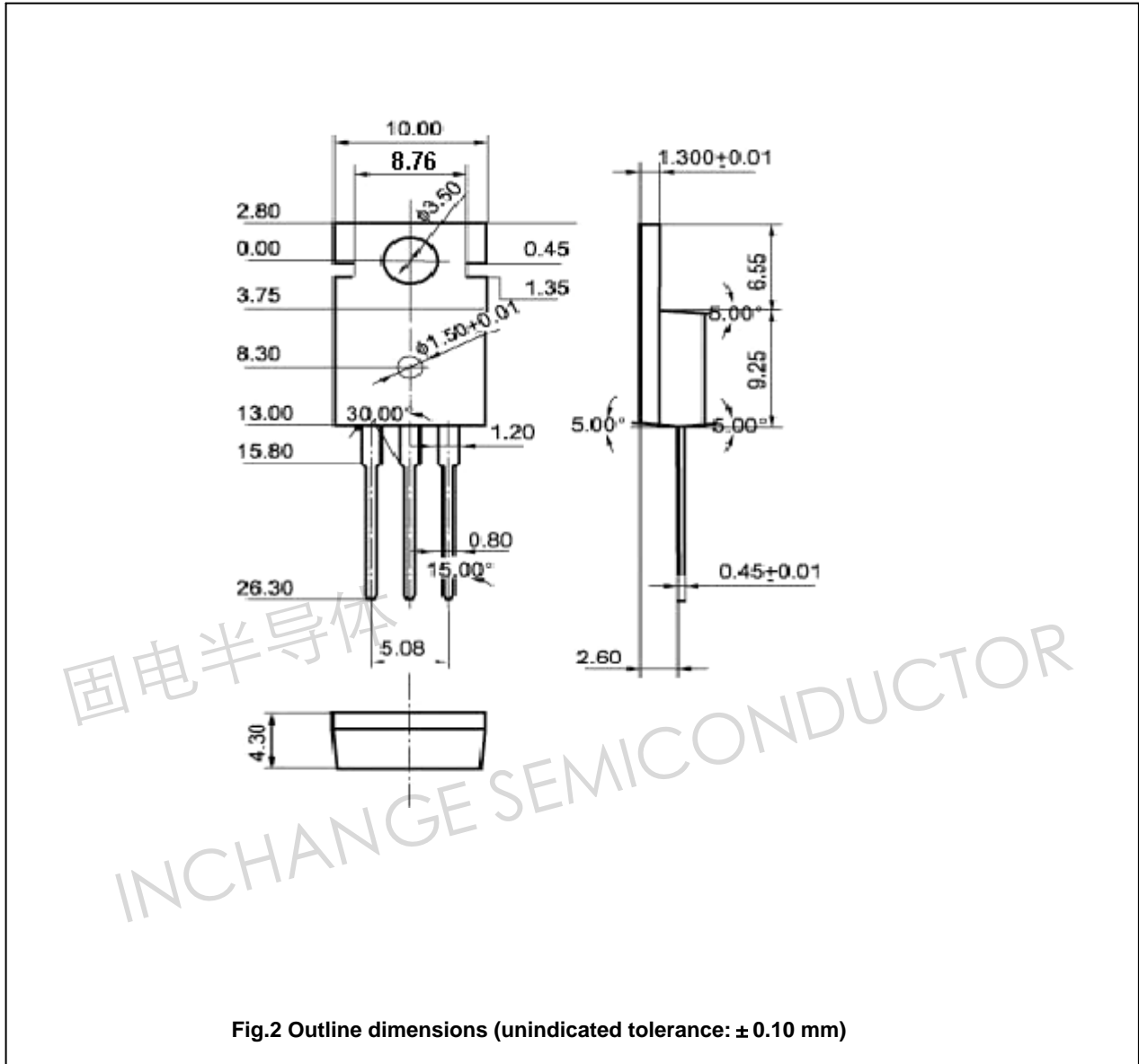

Silicon PNP Power Transistors

2SB859

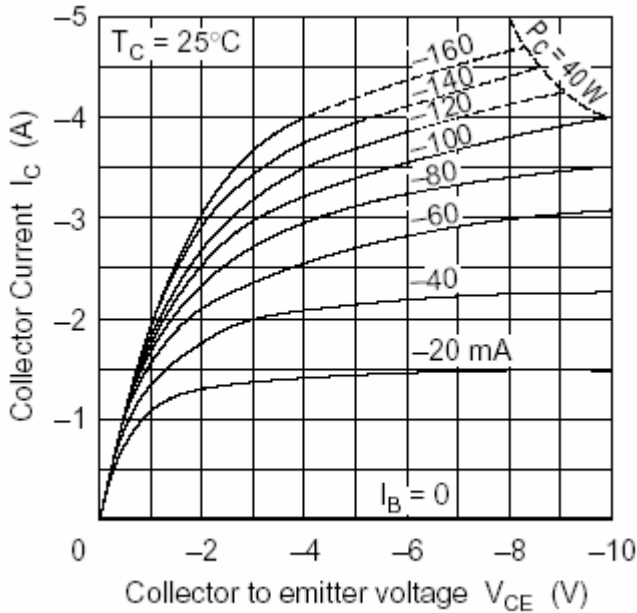

Fig.3 Static Characteristic

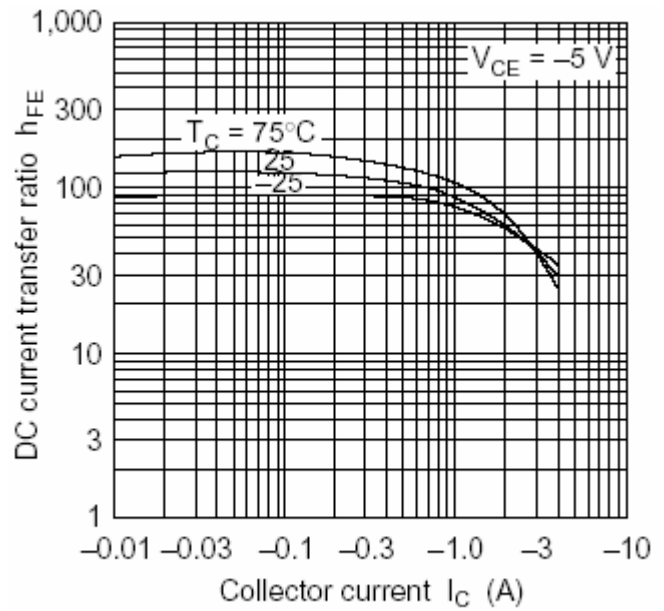

Fig.4 DC current Gain

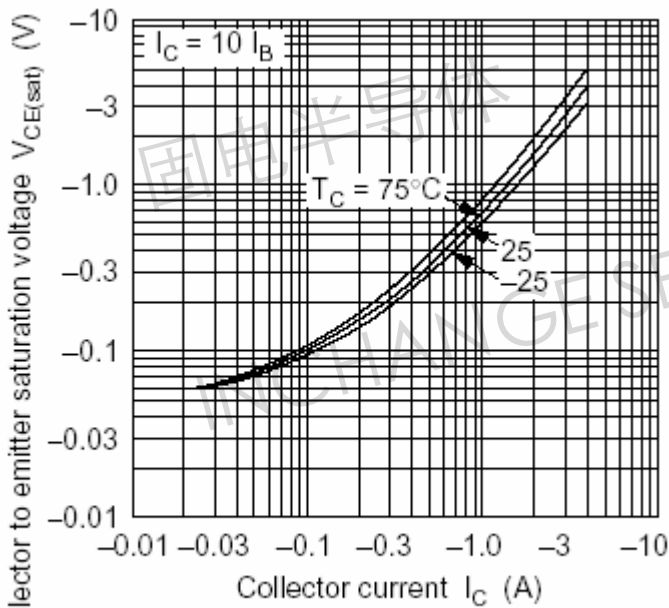

Fig.5 Collector-Emitter Saturation Voltage

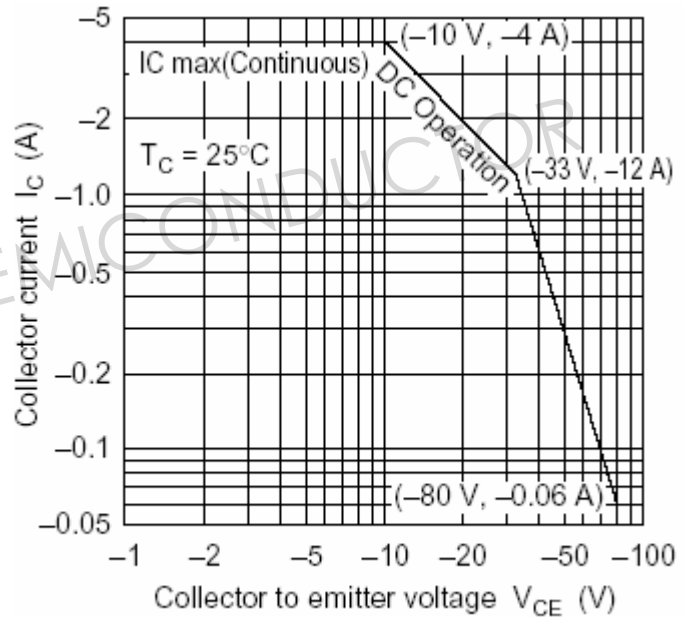

Fig.6 Safe Operating Area