

Silicon PNP Power Transistors

2SB869

DESCRIPTION

- With TO-220C package
- Complement to type 2SD961
- Low collector saturation voltage
- High collector current capability

APPLICATIONS

- For power switching applications

PINNING

PIN	DESCRIPTION
1	Emitter
2	Collector;connected to mounting base
3	Base

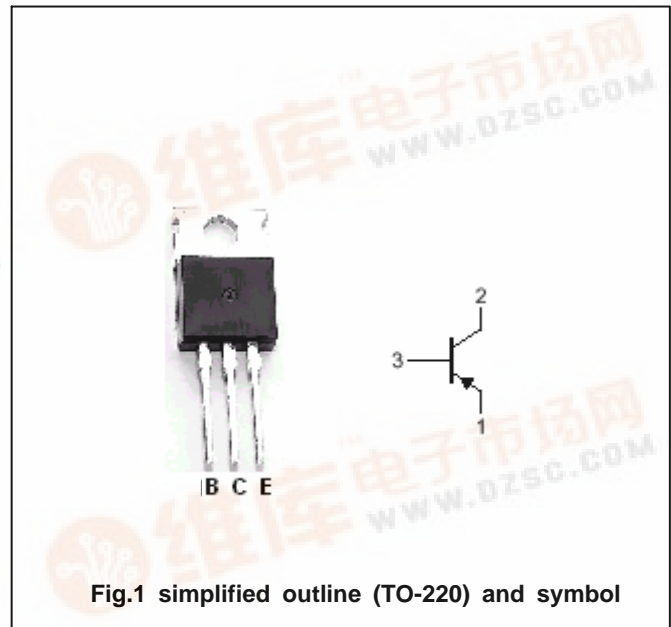

Absolute maximum ratings(Ta=25)

SYMBOL	PARAMETER	CONDITIONS	VALUE	UNIT
V _{CBO}	Collector-base voltage	Open emitter	-130	V
V _{CEO}	Collector-emitter voltage	Open base	-80	V
V _{EBO}	Emitter-base voltage	Open collector	-7	V
I _C	Collector current (DC)		-5	A
I _{CM}	Collector current-Peak		-10	A
P _C	Collector dissipation	T _C =25	40	W
T _j	Junction temperature		150	
T _{stg}	Storage temperature		-50~150	

Silicon PNP Power Transistors

2SB869

CHARACTERISTICS

T_j=25 unless otherwise specified

SYMBOL	PARAMETER	CONDITIONS	MIN	TYP.	MAX	UNIT
V _{(BR)CEO}	Collector-emitter breakdown voltage	I _C =-10mA; I _B =0	-80			V
V _{CEsat}	Collector-emitter saturation voltage	I _C =-4A; I _B =-0.2A			-0.5	V
V _{BEsat}	Base-emitter saturation voltage	I _C =-4A; I _B =-0.2A			-1.5	V
I _{CBO}	Collector cut-off current	V _{CB} =-100V; I _E =0			-10	μA
I _{EBO}	Emitter cut-off current	V _{EB} =-5V; I _C =0			-50	μA
h _{FE-1}	DC current gain	I _C =-0.1A; V _{CE} =-2V	45			
h _{FE-2}	DC current gain	I _C =-2A; V _{CE} =-2V	60		260	
f _T	Transition frequency	I _C =-0.5A; V _{CE} =-10V		30		MHz

Switching times

t _{on}	Turn-on time			0.13		μs
t _{stg}	Storage time	I _C =-2A; I _{B1} =-I _{B2} =-0.2A		0.5		μs
t _f	Fall time			0.13		μs

◆ h_{FE-2} Classifications

R	Q	P
60-120	90-180	130-260

Silicon PNP Power Transistors

2SB869

PACKAGE OUTLINE

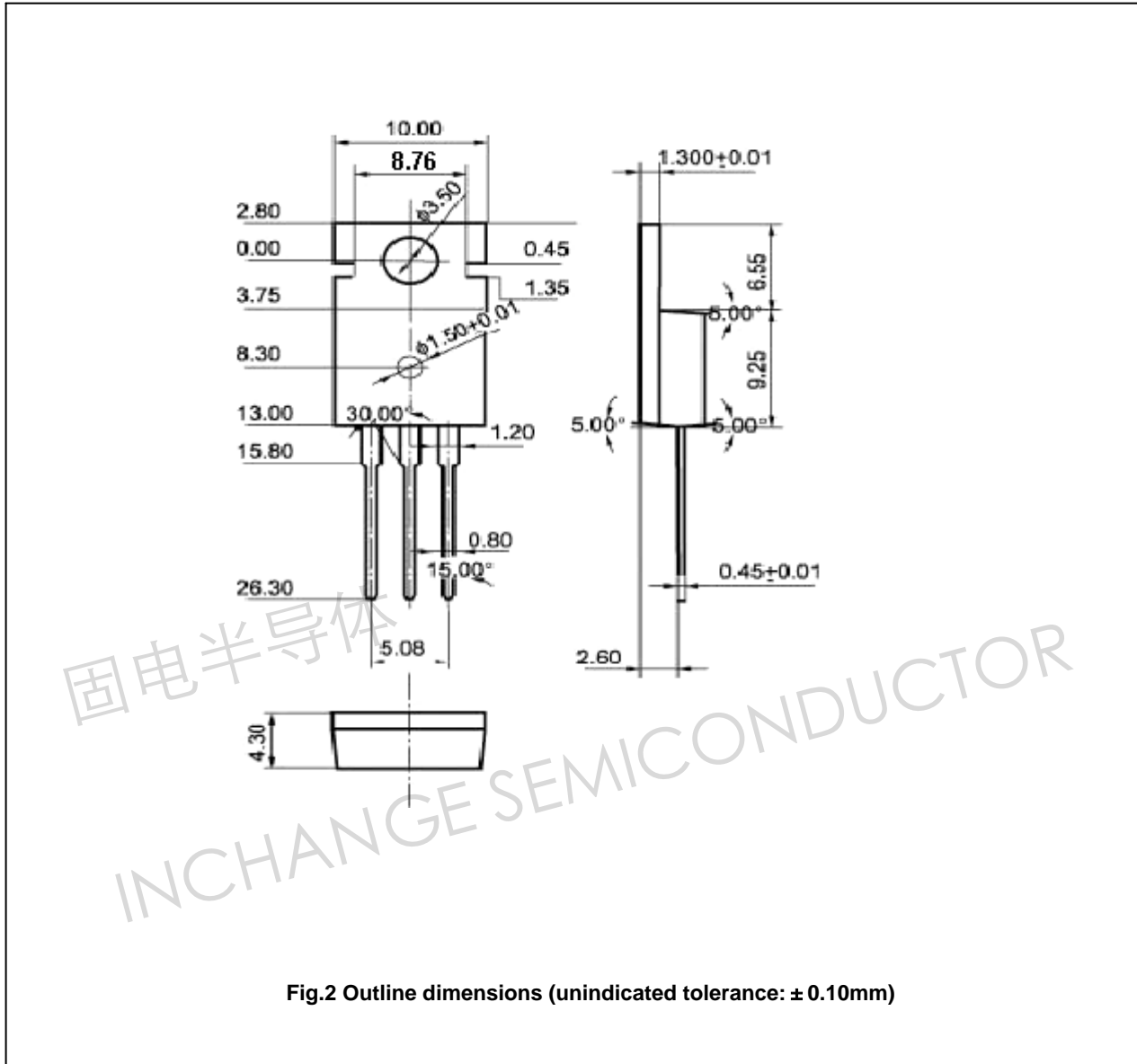

Fig.2 Outline dimensions (unindicated tolerance: ± 0.10mm)