

Inchange Semiconductor

Product Specification

Silicon NPN Power Transistors

2SC2899

DESCRIPTION

- With TO-126 package
- High voltage,high speed

APPLICATIONS

- For high speed and high voltage switching applications

PINNING

PIN	DESCRIPTION
1	Emitter
2	Collector
3	Base

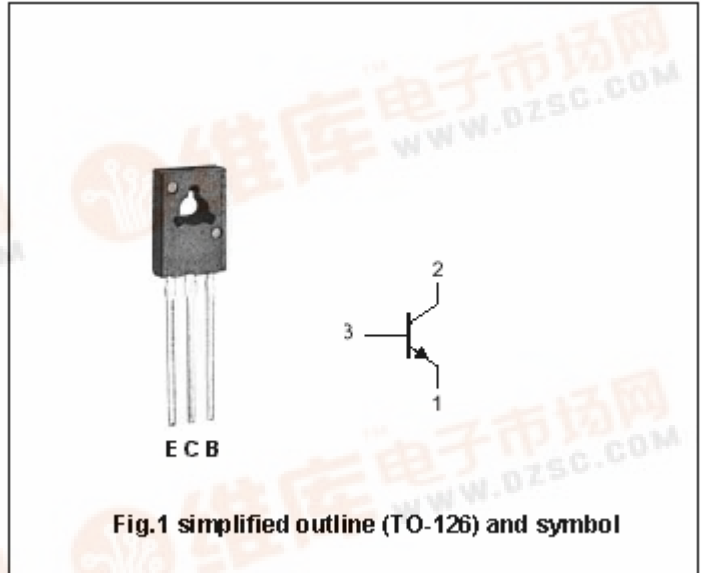

Absolute maximum ratings (Ta=25 )

SYMBOL	PARAMETER	CONDITIONS	VALUE	UNIT
$V_{CBO}$	Collector-base voltage	Open emitter	500	V
$V_{CEO}$	Collector-emitter voltage	Open base	400	V
$V_{EBO}$	Emitter-base voltage	Open collector	10	V
$I_C$	Collector current		0.5	A
$I_{CM}$	Collector current-peak		1.0	A
$P_C$	Collector power dissipation	$T_a=25$	0.75	W
		$T_C=25$	10	
$T_j$	Junction temperature		150	
$T_{stg}$	Storage temperature		-55~150	

## Silicon NPN Power Transistors

## 2SC2899

## CHARACTERISTICS

T<sub>j</sub>=25 unless otherwise specified

SYMBOL	PARAMETER	CONDITIONS	MIN	TYP.	MAX	UNIT
V <sub>CEO(SUS)</sub>	Collector-emitter sustaining voltage	I <sub>C</sub> =0.1A; R <sub>BE</sub> = , L=100mH	400			V
V <sub>(BR)EBO</sub>	Emitter-base breakdown voltage	I <sub>E</sub> =10mA; I <sub>C</sub> =0	10			V
V <sub>CEsat</sub>	Collector-emitter saturation voltage	I <sub>C</sub> =250mA; I <sub>B</sub> =50m A			1.0	V
V <sub>BEsat</sub>	Base-emitter saturation voltage	I <sub>C</sub> =250mA ; I <sub>B</sub> =50m A			1.5	V
h <sub>FE-1</sub>	DC current gain	I <sub>C</sub> =250mA ; V <sub>CE</sub> =5V	15			
h <sub>FE-2</sub>	DC current gain	I <sub>C</sub> =500mA ; V <sub>CE</sub> =5V	7			
I <sub>CBO</sub>	Collector cut-off current	V <sub>CB</sub> =400V; I <sub>E</sub> =0			20	μ A
I <sub>CEO</sub>	Collector cut-off current	V <sub>CE</sub> =350V; R <sub>BE</sub> =			50	μ A
Switching times						
t <sub>on</sub>	Turn-on time				1.0	μ s
t <sub>stg</sub>	Storage time	I <sub>C</sub> =0.5A; I <sub>B1</sub> =-I <sub>B2</sub> =0.1A V <sub>CC</sub> 150V			2.0	μ s
t <sub>f</sub>	Fall time				1.0	μ s

Silicon NPN Power Transistors

2SC2899

PACKAGE OUTLINE

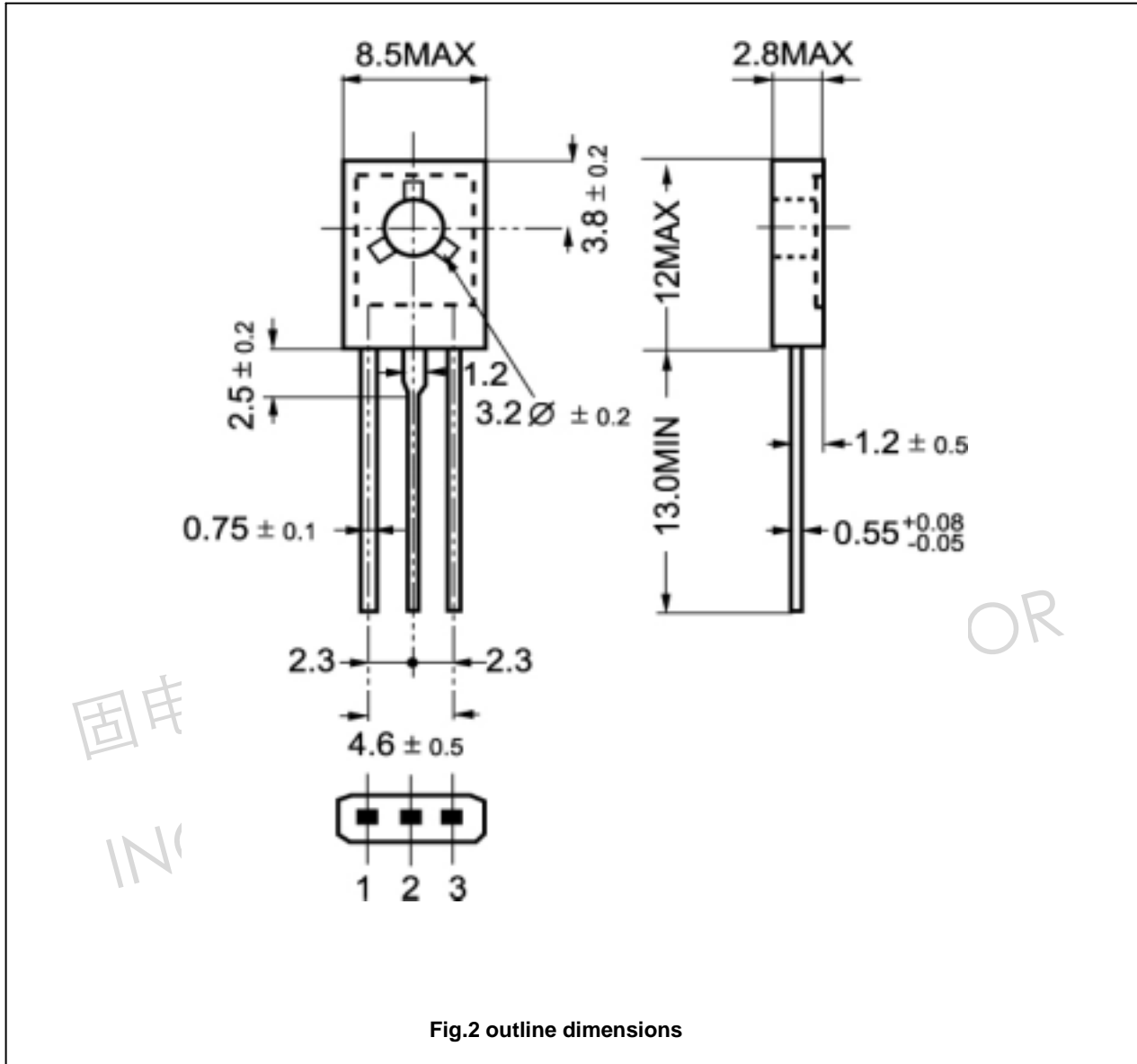

Fig.2 outline dimensions

Silicon NPN Power Transistors

2SC2899

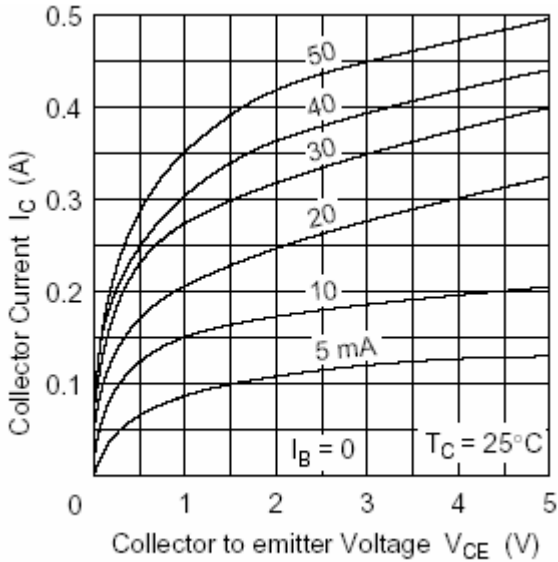

Fig.3 Static Characteristic

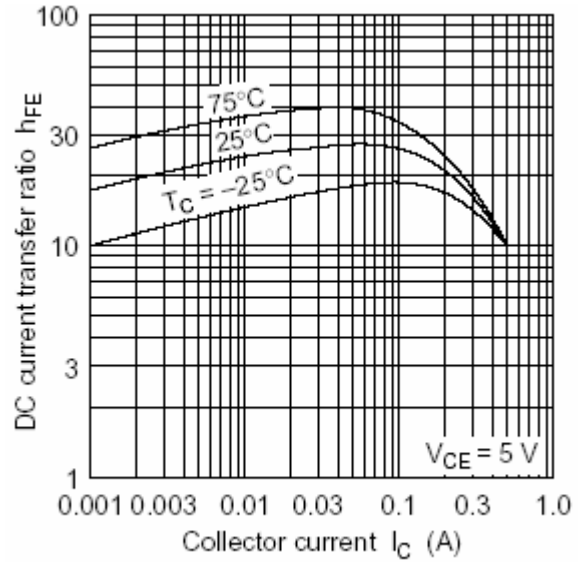

Fig.4 DC current Gain

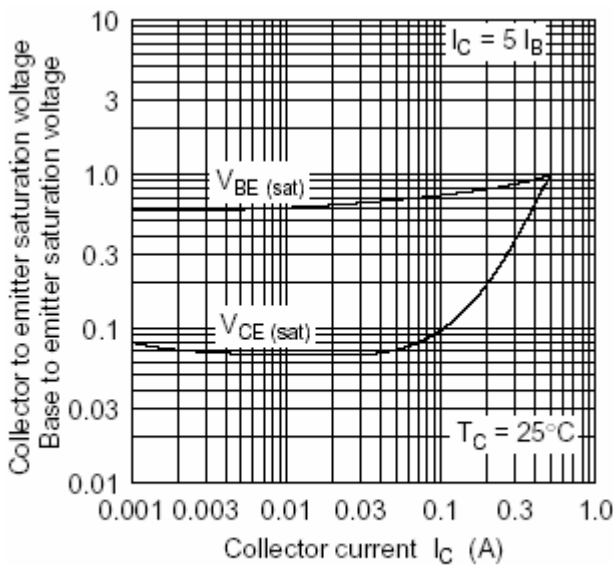

Fig.5 Base-Emitter Saturation Voltage  
Collector-Emitter Saturation Voltage

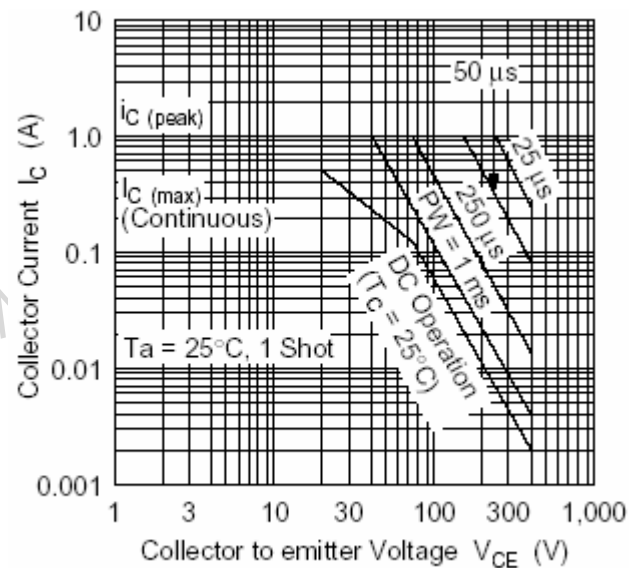

Fig.6 Safe Operating Area