

Inchange Semiconductor

Product Specification

Silicon NPN Power Transistors

2SC3318

DESCRIPTION

- With TO-3PN package
- High voltage ,high speed switching
- High reliability

APPLICATIONS

- Switching regulators
- Ultrasonic generators
- High frequency inverters
- General purpose power amplifiers

PINNING

PIN	DESCRIPTION
1	Base
2	Collector;connected to mounting base
3	Emitter

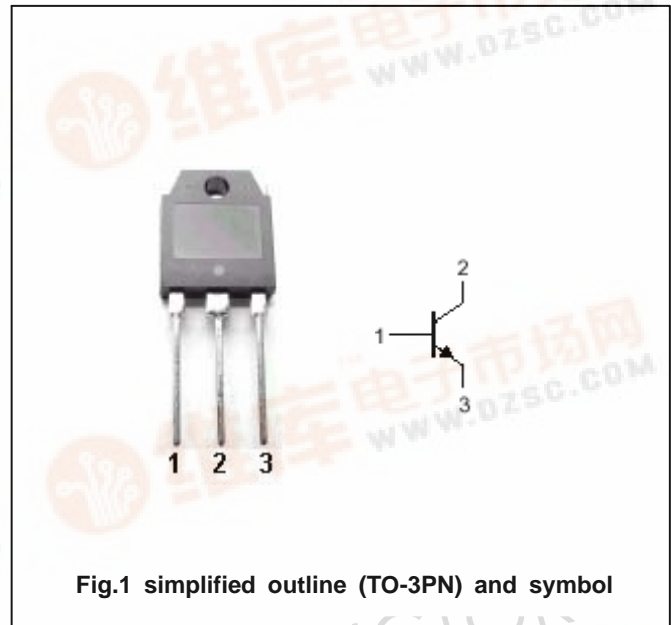

Fig.1 simplified outline (TO-3PN) and symbol

Absolute maximum ratings(Ta=25)

SYMBOL	PARAMETER	CONDITIONS	VALUE	UNIT
V_{CBO}	Collector-base voltage	Open emitter	500	V
V_{CEO}	Collector-emitter voltage	Open base	400	V
V_{EBO}	Emitter-base voltage	Open collector	7	V
I_C	Collector current		10	A
I_B	Base current		3	A
P_C	Collector power dissipation	$T_C=25$	80	W
T_j	Junction temperature		150	
T_{stg}	Storage temperature		-65~150	

THERMAL CHARACTERISTICS

SYMBOL	PARAMETER	VALUE	UNIT
$R_{th(j-c)}$	Thermal resistance from junction to case	1.55	/W

Silicon NPN Power Transistors

2SC3318

CHARACTERISTICS

T_j=25 unless otherwise specified

SYMBOL	PARAMETER	CONDITIONS	MIN	TYP.	MAX	UNIT
V _{(BR)CEO}	Collector-emitter breakdown voltage	I _C =10mA ; I _B =0	400			V
V _{(BR)CBO}	Collector-base breakdown voltage	I _C =1mA ; I _E =0	500			V
V _{(BR)EBO}	Emitter-base breakdown voltage	I _E =1mA ; I _C =0	7			V
V _{CEsat}	Collector-emitter saturation voltage	I _C =5A ; I _B =1A			1.0	V
V _{BEsat}	Base-emitter saturation voltage	I _C =5A ; I _B =1A			1.5	V
I _{CBO}	Collector cut-off current	V _{CB} =500V ; I _E =0			1.0	mA
I _{EBO}	Emitter cut-off current	V _{EB} =7V ; I _C =0			1.0	mA
h _{FE}	DC current gain	I _C =5A ; V _{CE} =5V	10			

Switching times resistive load

t _{on}	Turn-on time	I _C =5.0A I _{B1} =1A I _{B2} =-2A R _L =30ohm P _W =20 μs Duty=<2%			0.5	μs
t _s	Storage time				1.5	μs
t _f	Fall time				0.15	μs

Silicon NPN Power Transistors

2SC3318

PACKAGE OUTLINE

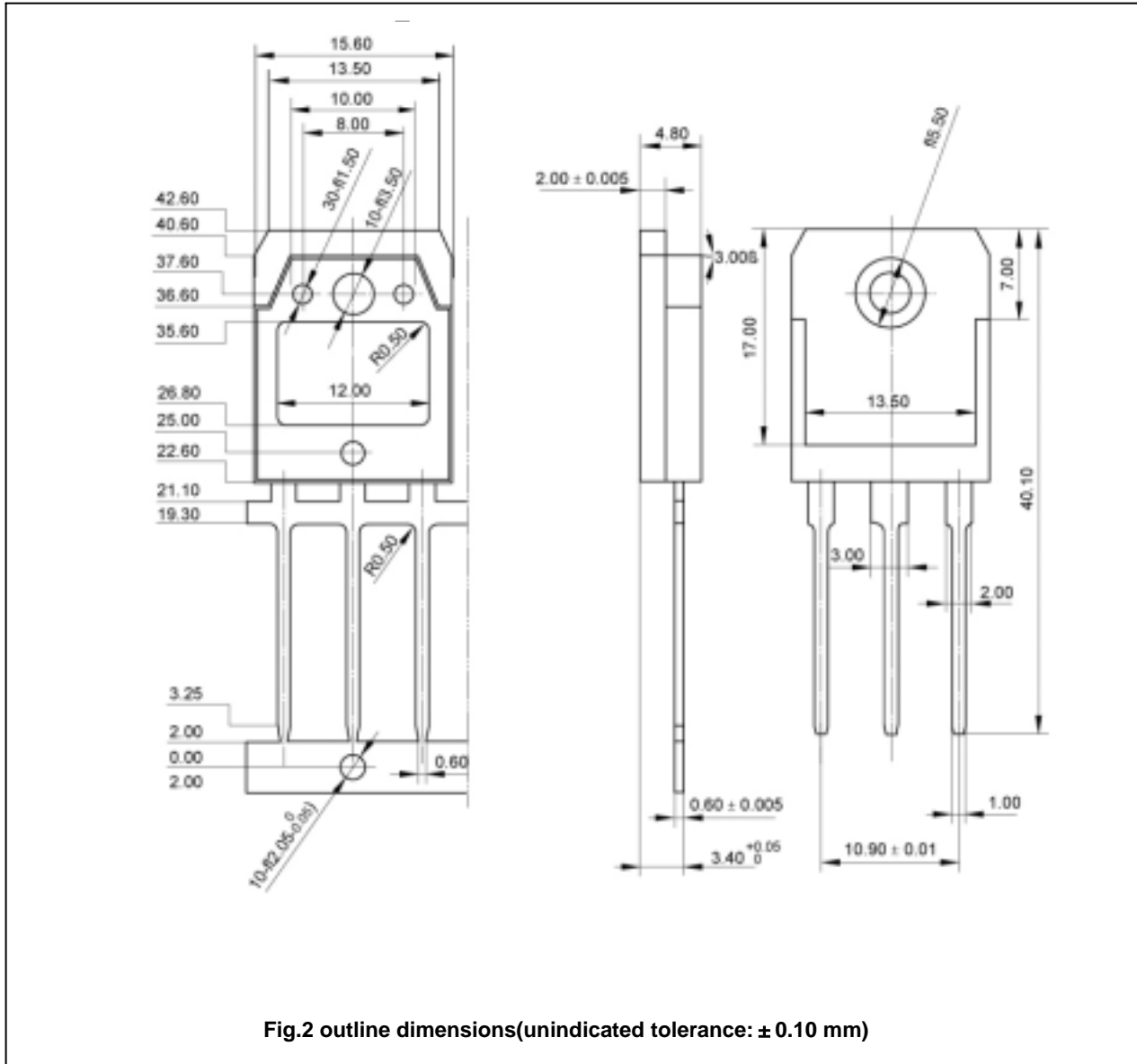

Silicon NPN Power Transistors

2SC3318

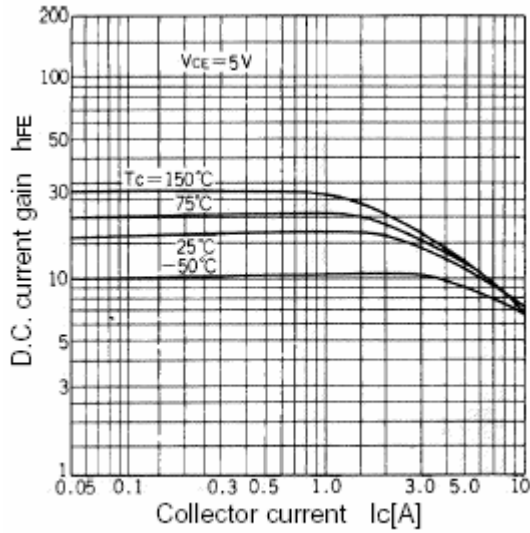

Fig.3 DC current Gain

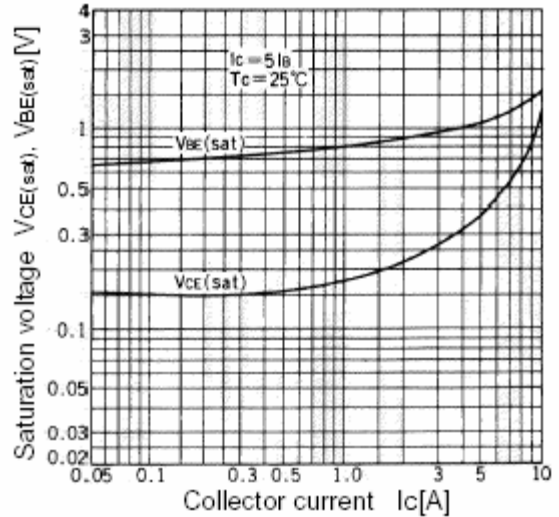

Fig.4 Base-Emitter Saturation Voltage
Collector-Emitter Saturation Voltage

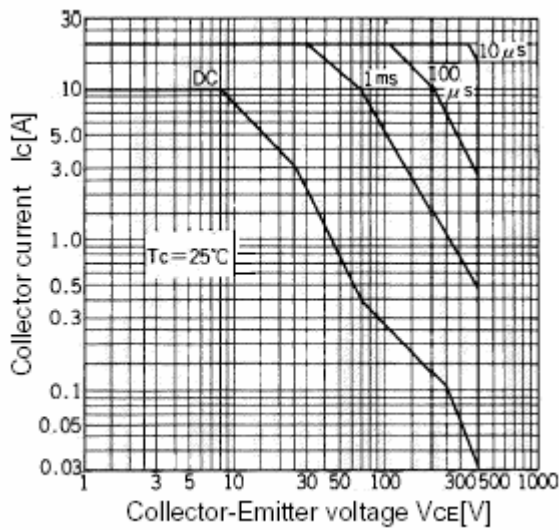

Fig.5 Safe Operating Area

SEMICONDUCTOR