

Inchange Semiconductor

Product Specification

Silicon PNP Power Transistors

TIP32/32A/32B/32C

DESCRIPTION

- With TO-220C package
- Complement to type TIP31/31A/31B/31C

APPLICATIONS

- Medium power linear and switching applications

PINNING

PIN	DESCRIPTION
1	Emitter
2	Collector;connected to mounting base
3	Base

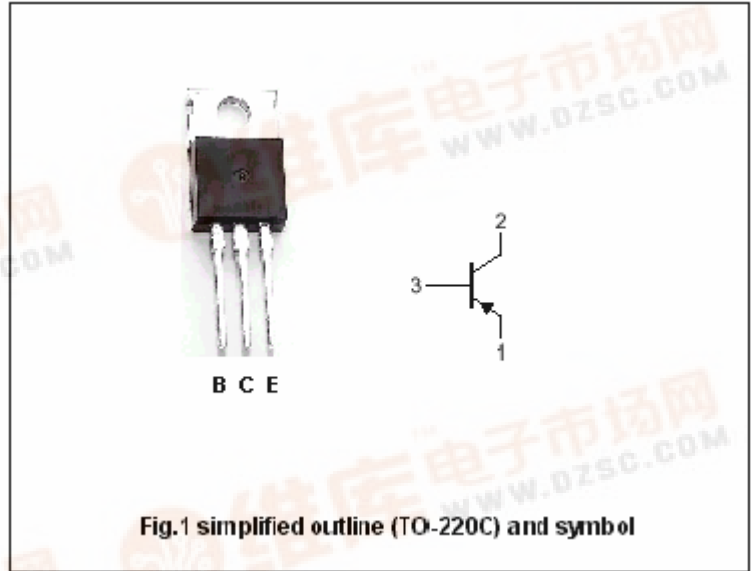

Absolute maximum ratings(Ta=25)

SYMBOL	PARAMETER	CONDITIONS	VALUE	UNIT
V _{CBO}	Collector-base voltage	TIP32	-40	V
		TIP32A	-60	
		TIP32B	-80	
		TIP32C	-100	
V _{CEO}	Collector-emitter voltage	TIP32	-40	V
		TIP32A	-60	
		TIP32B	-80	
		TIP32C	-100	
V _{EBO}	Emitter-base voltage	Open collector	-5	V
I _C	Collector current (DC)		-3	A
I _{CM}	Collector current-Pulse		-5	A
I _B	Base current		-1	A
P _C	Collector power dissipation	T _C =25	40	W
		T _a =25	2	
T _j	Junction temperature		150	
T _{stg}	Storage temperature		-65~150	

Silicon PNP Power Transistors

TIP32/32A/32B/32C

CHARACTERISTICS

T_j=25 unless otherwise specified

SYMBOL	PARAMETER	CONDITIONS	MIN	TYP.	MAX	UNIT	
V _{CEO(SUS)}	Collector-emitter sustaining voltage	TIP32	I _C =-30mA; I _B =0	-40		V	
		TIP32A		-60			
		TIP32B		-80			
		TIP32C		-100			
V _{CEsat}	Collector-emitter saturation voltage	I _C =-3A; I _B =-0.375A			-1.2	V	
V _{BE}	Base-emitter on voltage	I _C =-3A; V _{CE} =-4V			-1.8	V	
I _{CES}	Collector cut-off current	TIP32	V _{CE} =-40V; V _{EB} =0			-0.2	mA
		TIP32A	V _{CE} =-60V; V _{EB} =0				
		TIP32B	V _{CE} =-80V; V _{EB} =0				
		TIP32C	V _{CE} =-100V; V _{EB} =0				
I _{CEO}	Collector cut-off current	TIP32/32A	V _{CE} =-30V; I _B =0			-0.3	mA
		TIP32B/32C	V _{CE} =-60V; I _B =0				
I _{EBO}	Emitter cut-off current	V _{EB} =-5V; I _C =0			-1.0	mA	
h _{FE-1}	DC current gain	I _C =-1A; V _{CE} =-4V	25				
h _{FE-2}	DC current gain	I _C =-3A; V _{CE} =-4V	10		50		
f _T	Transiton frequency	I _C =-0.5A; V _{CE} =-10V	3			MHz	

Silicon PNP Power Transistors

TIP32/32A/32B/32C

PACKAGE OUTLINE

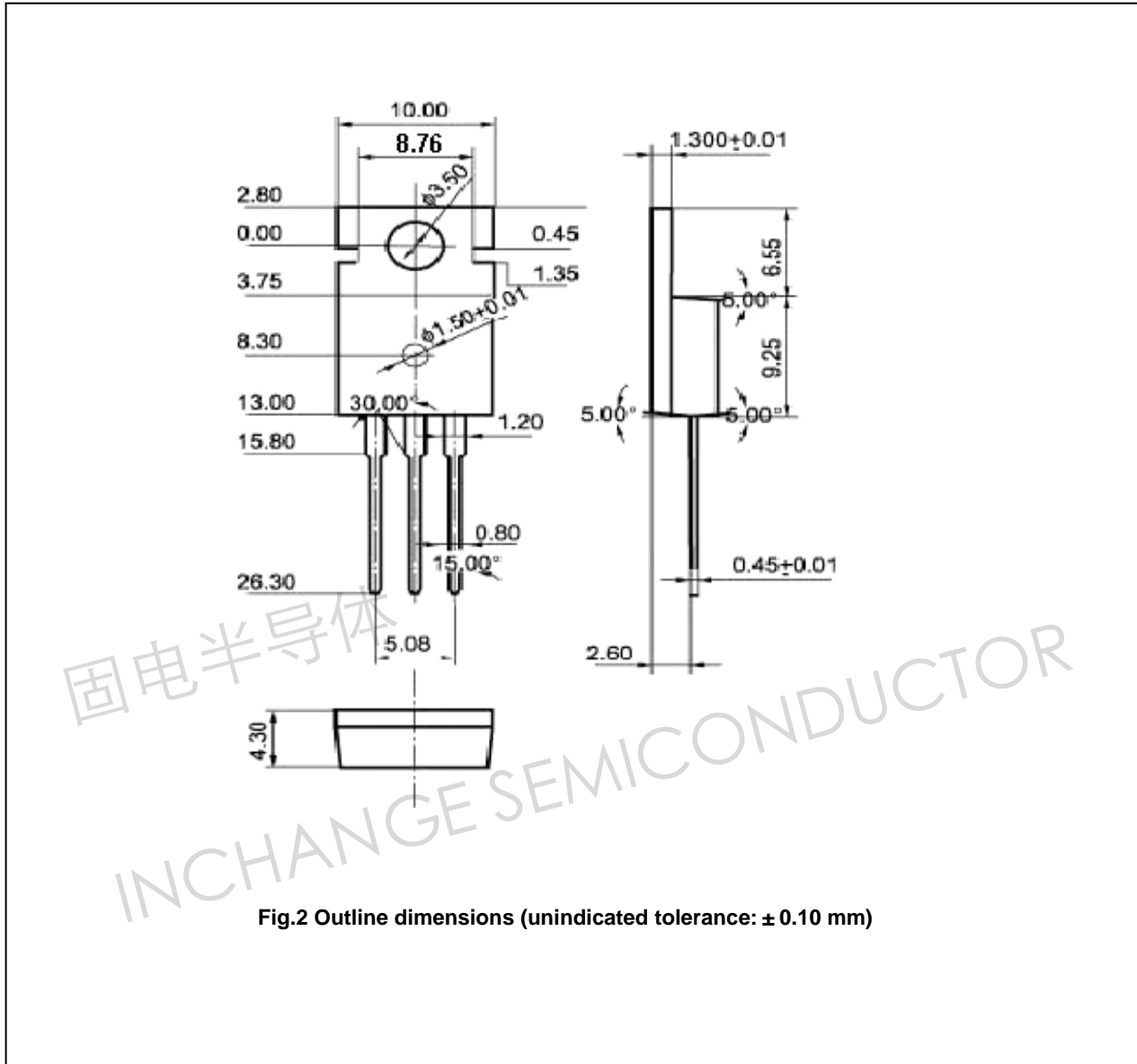

Silicon PNP Power Transistors

TIP32/32A/32B/32C

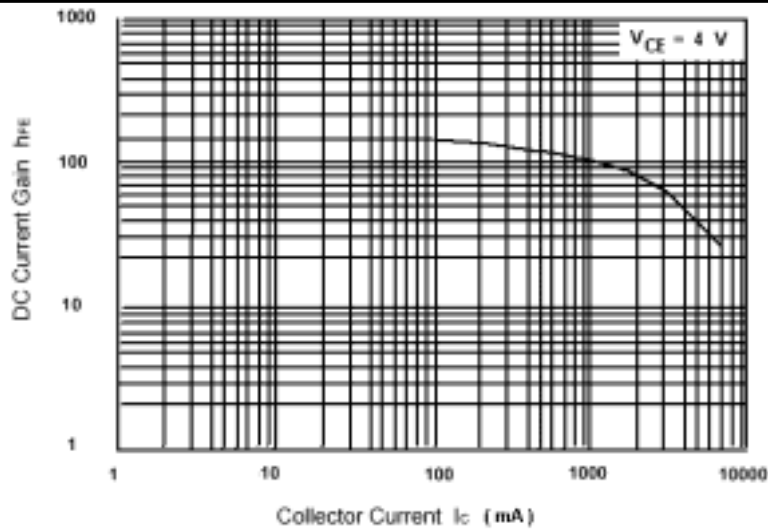

Fig.3 DC current Gain

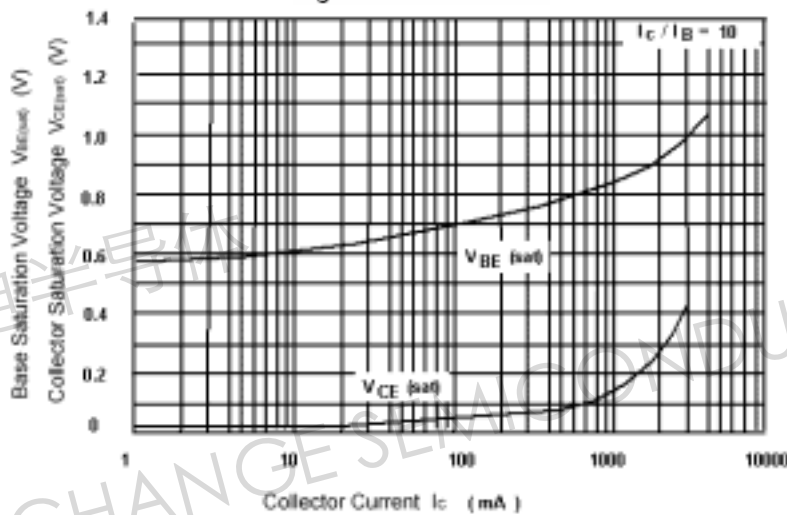

Fig.4 Base-Emitter Saturation Voltage
Collector-Emitter Saturation Voltage

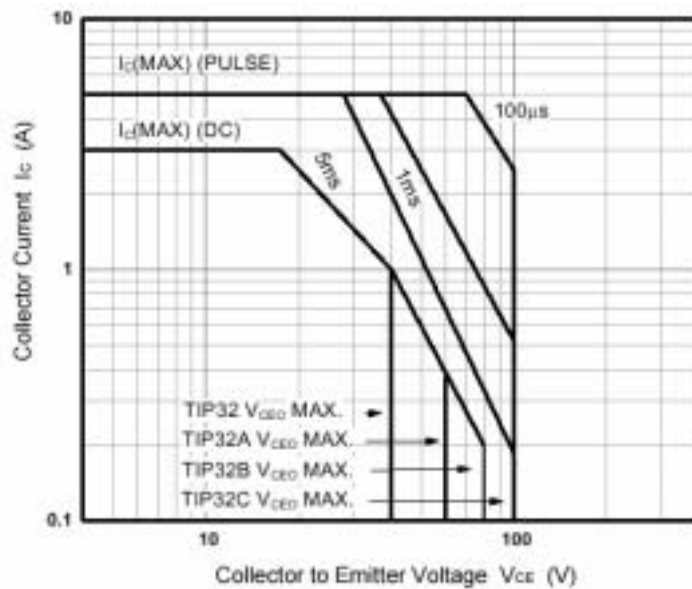

Fig.5 Safe Operating Area