

Inchange Semiconductor

Product Specification

Silicon PNP Power Transistors

2SA1491

DESCRIPTION

- With TO-3PN package
- Complement to type 2SC3855

APPLICATIONS

- Audio and general purpose

PINNING

PIN	DESCRIPTION
1	Base
2	Collector;connected to mounting base
3	Emitter

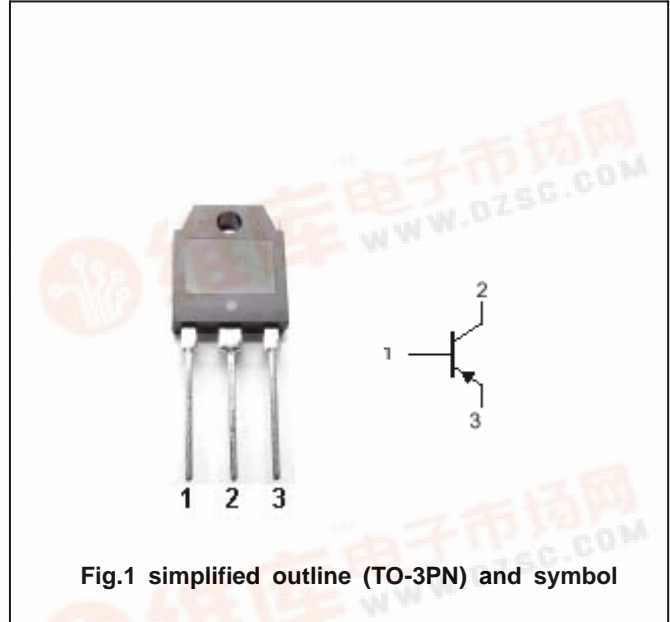

Absolute maximum ratings(Ta=°C)

SYMBOL	PARAMETER	CONDITIONS	VALUE	UNIT
V <sub>CBO</sub>	Collector-base voltage	Open emitter	-140	V
V <sub>CEO</sub>	Collector-emitter voltage	Open base	-140	V
V <sub>EBO</sub>	Emitter-base voltage	Open collector	-6	V
I <sub>C</sub>	Collector current		-10	A
I <sub>B</sub>	Base current		-4	A
P <sub>C</sub>	Collector power dissipation	T <sub>C</sub> =25°C	100	W
T <sub>j</sub>	Junction temperature		150	°C
T <sub>stg</sub>	Storage temperature		-55~150	°C

## Silicon PNP Power Transistors

## 2SA1491

## CHARACTERISTICS

T<sub>j</sub>=25°C unless otherwise specified

SYMBOL	PARAMETER	CONDITIONS	MIN	TYP.	MAX	UNIT
V <sub>(BR)CEO</sub>	Collector-emitter breakdown voltage	I <sub>C</sub> =-50mA ; I <sub>B</sub> =0	-140			V
V <sub>CEsat</sub>	Collector-emitter saturation voltage	I <sub>C</sub> =-5A; I <sub>B</sub> =-0.5A			-2.0	V
I <sub>CBO</sub>	Collector cut-off current	V <sub>CB</sub> =-140V; I <sub>E</sub> =0			-100	μ A
I <sub>EBO</sub>	Emitter cut-off current	V <sub>EB</sub> =-6V; I <sub>C</sub> =0			-100	μ A
h <sub>FE</sub>	DC current gain	I <sub>C</sub> =-3A ; V <sub>CE</sub> =-4V	50			
f <sub>T</sub>	Transition frequency	I <sub>C</sub> =0.5A ; V <sub>CE</sub> =-12V		20		MHz

## Switching times

t <sub>on</sub>	Turn-on time	I <sub>C</sub> =-5A; R <sub>L</sub> =12 Ω I <sub>B1</sub> =- I <sub>B2</sub> =-0.5A V <sub>CC</sub> =60V		0.30		μ s
t <sub>s</sub>	Storage time			0.90		μ s
t <sub>f</sub>	Fall time			0.20		μ s

Silicon PNP Power Transistors

2SA1491

PACKAGE OUTLINE

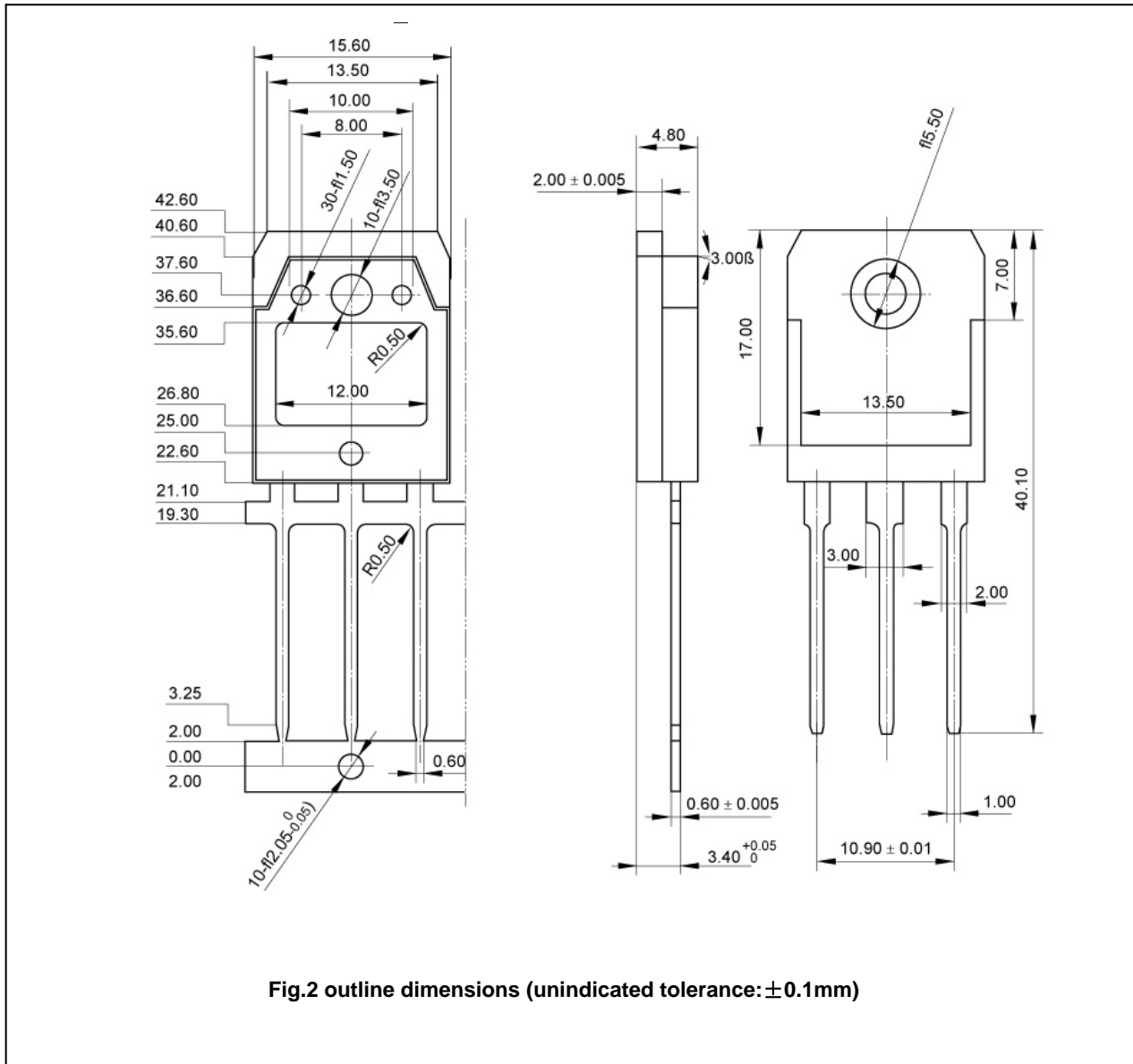

Silicon PNP Power Transistors

2SA1491

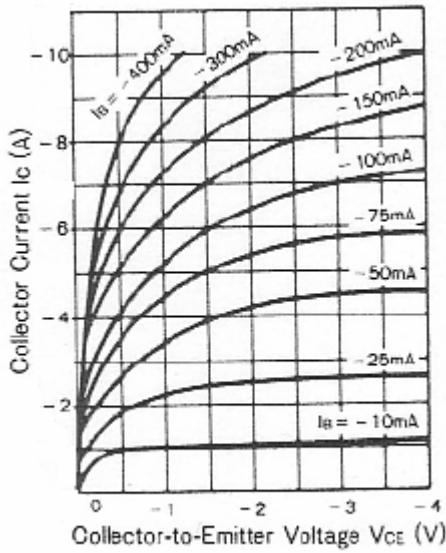

Fig.3 Static Characteristic

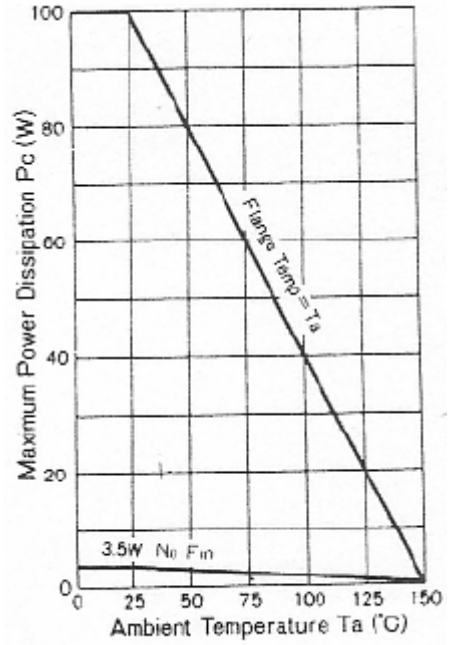

Fig.4 Power Derating

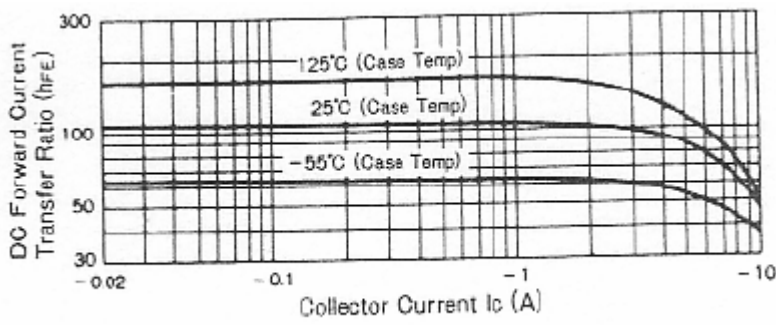

Fig.5 DC current Gain

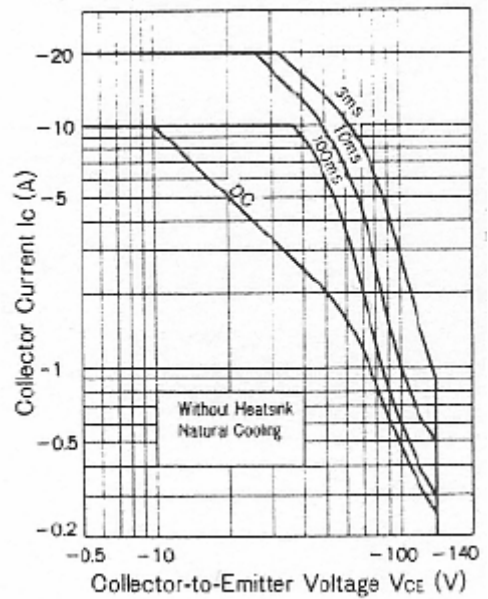

Fig.6 Safe Operating Area