

INCHANGE Semiconductor

isc Product Specification

isc Silicon NPN Power Transistor

BU2515DX

DESCRIPTION

- Collector-Emitter Sustaining Voltage-
: $V_{CEO(SUS)} = 800V$ (Min)
- High Switching Speed
- Built-in Damper Diode

APPLICATIONS

- Designed for use in horizontal deflection circuits of PC monitors.

ABSOLUTE MAXIMUM RATINGS($T_a=25^\circ C$)

SYMBOL	PARAMETER	VALUE	UNIT
V_{CES}	Collector- Emitter Voltage($V_{BE} = 0$)	1500	V
V_{CEO}	Collector-Emitter Voltage	800	V
V_{EBO}	Emitter-Base Voltage	7.5	V
I_C	Collector Current- Continuous	9	A
I_{CM}	Collector Current-Peak	20	A
I_B	Base Current- Continuous	5	A
I_{BM}	Base Current-Peak	7.5	A
P_C	Collector Power Dissipation @ $T_C=25^\circ C$	45	W
T_J	Junction Temperature	150	$^\circ C$
T_{stg}	Storage Temperature Range	-55~150	$^\circ C$

THERMAL CHARACTERISTICS

SYMBOL	PARAMETER	MAX	UNIT
$R_{th\ j-c}$	Thermal Resistance, Junction to Case	2.8	$^\circ C/W$

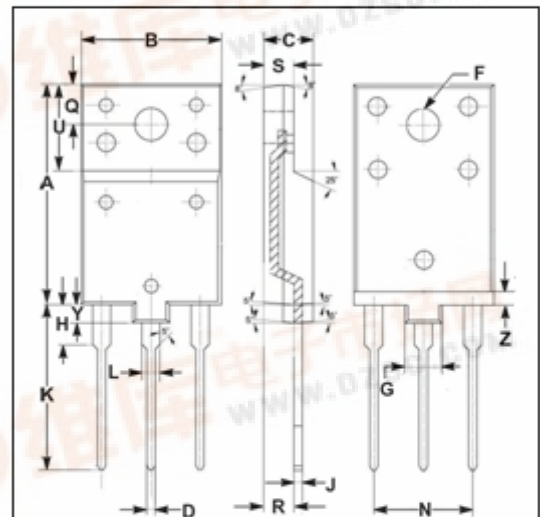
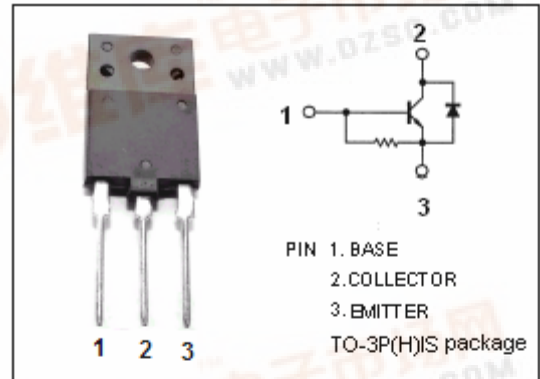

DIM	mm	
	MIN	MAX
A	24.30	24.70
B	15.20	15.80
C	5.20	5.80
D	0.65	0.85
F	3.30	3.90
G	3.90	4.10
H	4.30	4.70
J	0.80	1.00
K	18.30	18.70
L	1.90	2.10
N	10.70	11.10
Q	4.40	4.60
R	3.30	3.70
S	3.20	3.40
U	9.50	9.70
Y	1.90	2.10
Z	1.40	1.60



isc Silicon NPN Power Transistor

BU2515DX

ELECTRICAL CHARACTERISTICS

 $T_C=25^{\circ}\text{C}$ unless otherwise specified

SYMBOL	PARAMETER	CONDITIONS	MIN	TYP.	MAX	UNIT
$V_{CE(SUS)}$	Collector-Emitter Sustaining Voltage	$I_C=100\text{mA}; I_B=0, L=25\text{mH}$	800			V
$V_{(BR)EBO}$	Emitter-Base Breakdown Voltage	$I_E=600\text{mA}; I_C=0$	7.5			V
$V_{CE(sat)}$	Collector-Emitter Saturation Voltage	$I_C=4.5\text{A}; I_B=0.9\text{A}$			5.0	V
$V_{BE(sat)}$	Base-Emitter Saturation Voltage	$I_C=4.5\text{A}; I_B=0.9\text{A}$			1.0	V
I_{CES}	Collector Cutoff Current	$V_{CE}=BV_{CES}; V_{BE}=0$ $V_{CE}=BV_{CES}; V_{BE}=0; T_C=125^{\circ}\text{C}$			1.0 2.0	mA
I_{EBO}	Emitter Cutoff Current	$V_{EB}=6\text{V}; I_C=0$		130		mA
h_{FE-1}	DC Current Gain	$I_C=1\text{A}; V_{CE}=5\text{V}$		13		
h_{FE-2}	DC Current Gain	$I_C=4.5\text{A}; V_{CE}=5\text{V}$	5		10.2	
V_{ECF}	C-E Diode Forward Voltage	$I_F=4.5\text{A}$			2.2	V