

Embedded Power for  
Business-Critical Continuity

## BXA3 Series Single output

Total Power: 5W  
Input Voltage: 38 - 72VDC  
# of Outputs: Single



Rev.03.07.07  
bxa3  
1 of 4

## Special Features

- 3 Watts in DIL Package
- 9 models including 3.3 Vdc output
- Wide input ranges 9 Vdc to 18 Vdc, 18 Vdc to 36 Vdc, 36 Vdc to 75 Vdc
- EN55022 conducted emissions level A (optional)
- Continuous short circuit protection
- Operating temperature range -25 °C to +105 °C
- Input voltage range to ETS300-132-2
- UL, VDE and CSA safety approvals
- Available RoHS compliant
- 2 year warranty

The BXA3 Series of dc-dc converters is designed to offer the optimum cost/benefit power solution for a wide variety of applications including public and private telecommunications, industrial systems and process and test equipment. The series consists of 9 models with input voltages of 9 Vdc to 18Vdc, 18 Vdc to 36 Vdc and 36 Vdc to 75 Vdc, and offers standard output voltages of 3.3 V, 5 V, 12 V and 15 V in single and dual output configurations. Continuous short-circuit protection, overvoltage protection, 60 mV output ripple and EN55022 level A conducted noise compliance minimize design-in time, cost and eliminate the need for external components.

## Safety

VDE0805/EN60950/IEC950  
File No. 10401-3336-0098  
Licence No. 5856

UL950 File No. E136005  
CSA C22.2 No. 950  
File No. LR41062C

ARTESYN®

  
**EMERSON™**  
Network Power

# Specifications

All specifications are typical at nominal input, full load at 25°C unless otherwise stated.

## OUTPUT SPECIFICATIONS

|                                      |                       |                                  |
|--------------------------------------|-----------------------|----------------------------------|
| Voltage accuracy                     |                       | ±1.0%                            |
| Line regulation                      | LL to HL, all outputs | ±2.5%                            |
| Load regulation                      | Full load to no load  | ±2.5%                            |
| Ripple and noise<br>(5 Hz to 20 MHz) | +5 V output           | 60 mV pk-pk, max.,<br>15 mV rms  |
|                                      | All others            | 100 mV pk-pk, max.,<br>15 mV rms |
| Temperature coefficient              |                       | ±0.02%/°C, max.                  |
| Over voltage protection              | Clamp diode           | 135% Vout                        |
| Short circuit protection             |                       | Continuous automatic recovery    |

## INPUT SPECIFICATIONS

|                               |                                     |           |
|-------------------------------|-------------------------------------|-----------|
| Input voltage range           | 12 Vdc                              | 9-18 Vdc  |
|                               | 24 Vdc                              | 18-36 Vdc |
|                               | 48 Vdc                              | 36-75 Vdc |
| Input filter                  | Suffix '-F' (See Note 5)            | Pi type   |
| Reverse voltage protection    | (See Note 7)                        | Yes       |
| Max. input rise and fall time | Output remains within specification | 5 V/ms    |

## EMC CHARACTERISTICS

|                     |   |         |
|---------------------|---|---------|
| Conducted emissions | EN55022, FCC part 15<br>Suffix '-F' versions<br>(See Notes 5 and 6) | Level A |
|---------------------|---|---------|

## GENERAL SPECIFICATIONS

|                         |               |   |
|-------------------------|---------------|---|
| Efficiency              |               | See table   |
| Isolation voltage       | Input/output  | 500 Vdc   |
| Switching frequency     | Variable      | 200 kHz to 1 MHz                                      |
| Approvals and standards |               | VDE0805, EN60950, IEC950<br>UL1950, CSA C22.2 No. 950 |
| Case material           |               | Non-conductive black plastic                          |
| Material flammability   |               | UL94V-0 min.  |
| Weight                  |               | 15 g (0.53 oz)  |
| MTBF                    | MIL-HDBK-217F | 800,000 hours   |

## ENVIRONMENTAL SPECIFICATIONS

|                     |   |   |
|---------------------|---|---|
| Thermal performance | Operating ambient<br>(See derating curve) | -25 °C to +105 °C                               |
|                     | Non-operating amb<br>Cooling              | -40 °C to +105 °C<br>Free air convection cooled |
|                     |   |   |
| Relative humidity   | Non-condensing                            | 5% to 95% RH                                    |
| Altitude            | Operating                                 | 10,000 feet max.                                |
|                     | Non operating                             | 40,000 feet max.                                |
| Vibration           | 5 Hz to 500 Hz                            | 2.5 G rms (approx.)                             |

## Specifications Contd.

| INPUT<br>VOLTAGE | OUTPUT<br>VOLTAGE | OUTPUT<br>CURRENT <sup>(1)</sup> | INPUT<br>CURRENT <sup>(2)</sup> | TYPICAL<br>EFFICIENCY | REGULATION          |                     | MODEL<br>NUMBER <sup>(5,8,9)</sup> |
|------------------|-------------------|----------------------------------|---------------------------------|-----------------------|---------------------|---------------------|------------------------------------|
|                  |                   |                                  |                                 |                       | LINE <sup>(3)</sup> | LOAD <sup>(4)</sup> |                                    |
| 9-18 Vdc         | 3.3 V             | 600 mA                           | 245 mA                          | 68%                   | ±2.5%               | ±2.5%               | BXA3-12S3V3J                       |
| 9-18 Vdc         | 15 V              | 200 mA                           | 335 mA                          | 75%                   | ±2.5%               | ±2.5%               | BXA3-12S15J                        |
| 18-36 Vdc        | 3.3 V             | 600 mA                           | 122 mA                          | 68%                   | ±2.5%               | ±2.5%               | BXA3-24S3V3J                       |
| 18-36 Vdc        | 5 V               | 500 mA                           | 140 mA                          | 76%                   | ±2.5%               | ±2.5%               | BXA3-24S05J                        |
| 18-36 Vdc        | ±5 V              | ±250 mA                          | 140 mA                          | 76%                   | ±2.5%               | ±2.5%               | BXA3-24D05J                        |
| 36-75 Vdc        | 3.3 V             | 600 mA                           | 61 mA                           | 68%                   | ±2.5%               | ±2.5%               | BXA3-48S3V3J                       |
| 36-75 Vdc        | 5 V               | 500 mA                           | 69 mA                           | 76%                   | ±2.5%               | ±2.5%               | BXA3-48S05J                        |
| 36-75 Vdc        | 12 V              | 250 mA                           | 83 mA                           | 76%                   | ±2.5%               | ±2.5%               | BXA3-48S12J                        |
| 36-75 Vdc        | 15 V              | 200 mA                           | 83 mA                           | 76%                   | ±2.5%               | ±2.5%               | BXA3-48S15J                        |

### Notes

- 1 Maximum.
- 2 Maximum figure at full load (nominal).
- 3 Low line to high line.
- 4 Full load to no load.
- 5 An optional internal filter is available. When the filter is added, the BXA3 will meet VDE0871-A, VDE0878-A and EN55022-A. Add the suffix '-F' to the model number, e.g. **BXA3-12S15-FJ**.
- 6 Conducted noise filtering to EN55022 level B may be accomplished by putting the following capacitors across the input pins.
 

|        |                                  |
|--------|----------------------------------|
| 12 Vdc | 5 µF ceramic X7R dielectric type |
| 24 Vdc | 3 µF ceramic X7R dielectric type |
| 48 Vdc | 1 µF ceramic X7R dielectric type |
- 7 Reverse voltage protection can be implemented by putting a fast blow fuse on the positive input rail. Rate the fuse for 250 mA at 48 Vdc input, 500 mA at 24 Vdc input and 1000 mA at 12 Vdc input.
- 8 The 'J' suffix indicates that these parts are Pb-free (RoHS 6/6) compliant. TSE RoHS 5/6 (non Pb-free) compliant versions may be available on special request, please contact your local sales representative for details.
- 9 NOTICE: Some models do not support all options. Please contact your local Artesyn representative or use the on-line model number search tool at <http://www.artesyn.com/powergroup/products.htm> to find a suitable alternative.

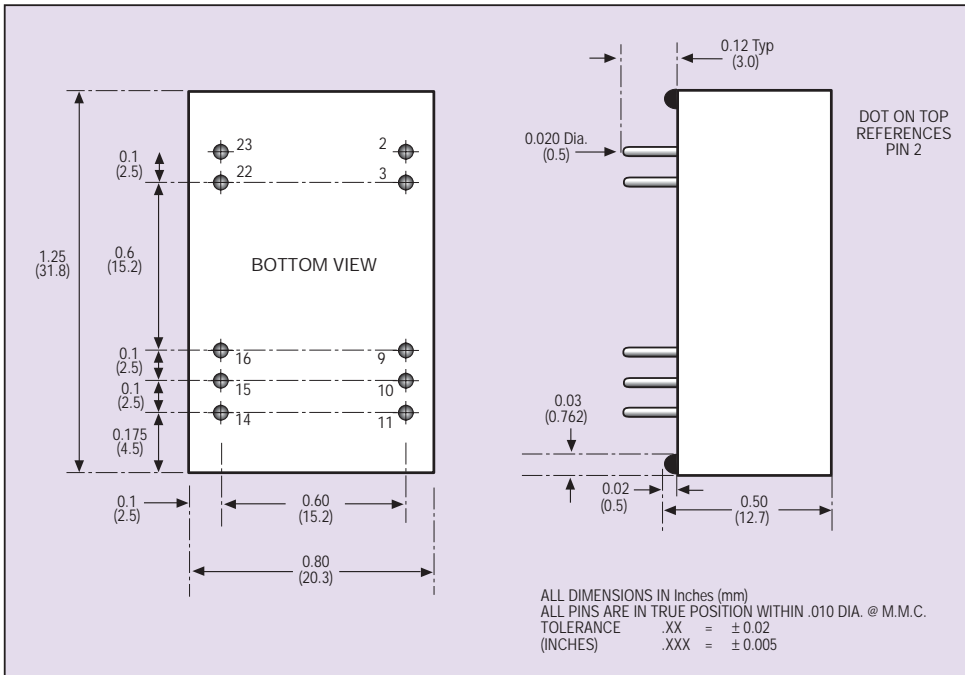

| PIN CONNECTIONS |               |             |
|-----------------|---------------|-------------|
| PIN NUMBER      | SINGLE OUTPUT | DUAL OUTPUT |
| 2               | -Vin          | -Vin        |
| 3               | -Vin          | -Vin        |
| 22              | +Vin          | +Vin        |
| 23              | +Vin          | +Vin        |
| 9               | No Pin        | Common      |
| 10              | No Pin        | No Pin      |
| 11              | No Connection | -Vout       |
| 14              | +Vout         | +Vout       |
| 15              | No Pin        | No Pin      |
| 16              | -Vout         | Common      |

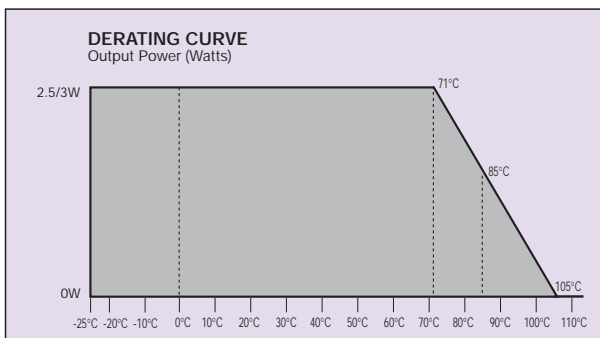

### Americas

5810 Van Allen Way  
Carlsbad, CA 92008  
USA  
Telephone: +1 760 930 4600  
Facsimile: +1 760 930 0698

### Europe (UK)

Waterfront Business Park  
Merry Hill, Dudley  
West Midlands, DY5 1LX  
United Kingdom  
Telephone: +44 (0) 1384 842 211  
Facsimile: +44 (0) 1384 843 355

### Asia (HK)

16th - 17th Floors, Lu Plaza  
2 Wing Yip Street, Kwun Tong  
Kowloon, Hong Kong  
Telephone: +852 2176 3333  
Facsimile: +852 2176 3888

For global contact, visit:

[www.powerconversion.com](http://www.powerconversion.com)  
[technicalsupport@powerconversion.com](mailto:technicalsupport@powerconversion.com)

While every precaution has been taken to ensure accuracy and completeness in this literature, Emerson Network Power assumes no responsibility, and disclaims all liability for damages resulting from use of this information or for any errors or omissions.

### Emerson Network Power.

The global leader in enabling business-critical continuity.

- AC Power
- Connectivity
- DC Power
- Embedded Power
- Inbound Power
- Integrated Cabinet Solutions
- Outside Plant
- Precision Cooling
- Site Monitoring and Services

[EmersonNetworkPower.com](http://EmersonNetworkPower.com)

Emerson Network Power and the Emerson Network Power logo are trademarks and service marks of Emerson Electric Co. ©2007 Emerson Electric Co.