

Inchange Semiconductor

Product Specification

Silicon NPN Power Transistors

2SC2438

DESCRIPTION

- With TO-220C package
- Low collector saturation voltage
- High reliability

APPLICATIONS

- Switching regulators
- Ultrasonic generators
- High frequency inverters
- General purpose power amplifiers

PINNING

PIN	DESCRIPTION
1	Base
2	Collector;connected to mounting base
3	Emitter

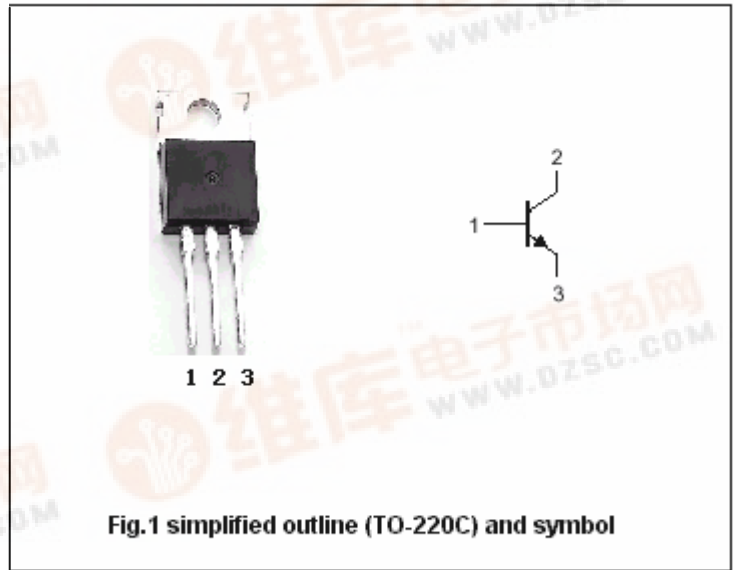

Absolute maximum ratings(Ta=25)

SYMBOL	PARAMETER	CONDITIONS	VALUE	UNIT
V _{CBO}	Collector-base voltage	Open emitter	150	V
V _{CEO}	Collector-emitter voltage	Open base	80	V
V _{EBO}	Emitter-base voltage	Open collector	7	V
I _C	Collector current		7	A
I _B	Base current		2	A
P _C	Collector power dissipation	T _C =25	50	W
T _j	Junction temperature		150	
T _{stg}	Storage temperature		-55~150	

THERMAL CHARACTERISTICS

SYMBOL	PARAMETER	MAX	UNIT
R _{th j-c}	Thermal resistance junction case	2.5	/W

Silicon NPN Power Transistors

2SC2438

CHARACTERISTICS

T_j=25 unless otherwise specified

SYMBOL	PARAMETER	CONDITIONS	MIN	TYP.	MAX	UNIT
V _{(BR)CEO}	Collector-emitter breakdown voltage	I _C =10mA ; I _B =0	80			V
V _{(BR)CBO}	Collector-base breakdown voltage	I _C =100 μ A ; I _E =0	150			V
V _{(BR)EBO}	Emitter-base breakdown voltage	I _E =100 μ A ; I _C =0	7			V
V _{CEsat}	Collector-emitter saturation voltage	I _C =4A; I _B =0.4A			0.5	V
V _{BEsat}	Base-emitter saturation voltage	I _C =4A; I _B =0.4A			1.2	V
I _{CBO}	Collector cut-off current	V _{CB} =150V ; I _E =0			100	μ A
I _{EBO}	Emitter cut-off current	V _{EB} =7V; I _C =0			100	μ A
h _{FE}	DC current gain	I _C =4 A ; V _{CE} =1V	30			
Switching times						
t _{on}	Turn-on time	I _C =4A; I _{B1} =0.4A I _{B2} =-0.4A; R _L =5			0.5	μ s
t _s	Storage time				2.5	μ s
t _f	Fall time				0.3	μ s

Silicon NPN Power Transistors

2SC2438

PACKAGE OUTLINE

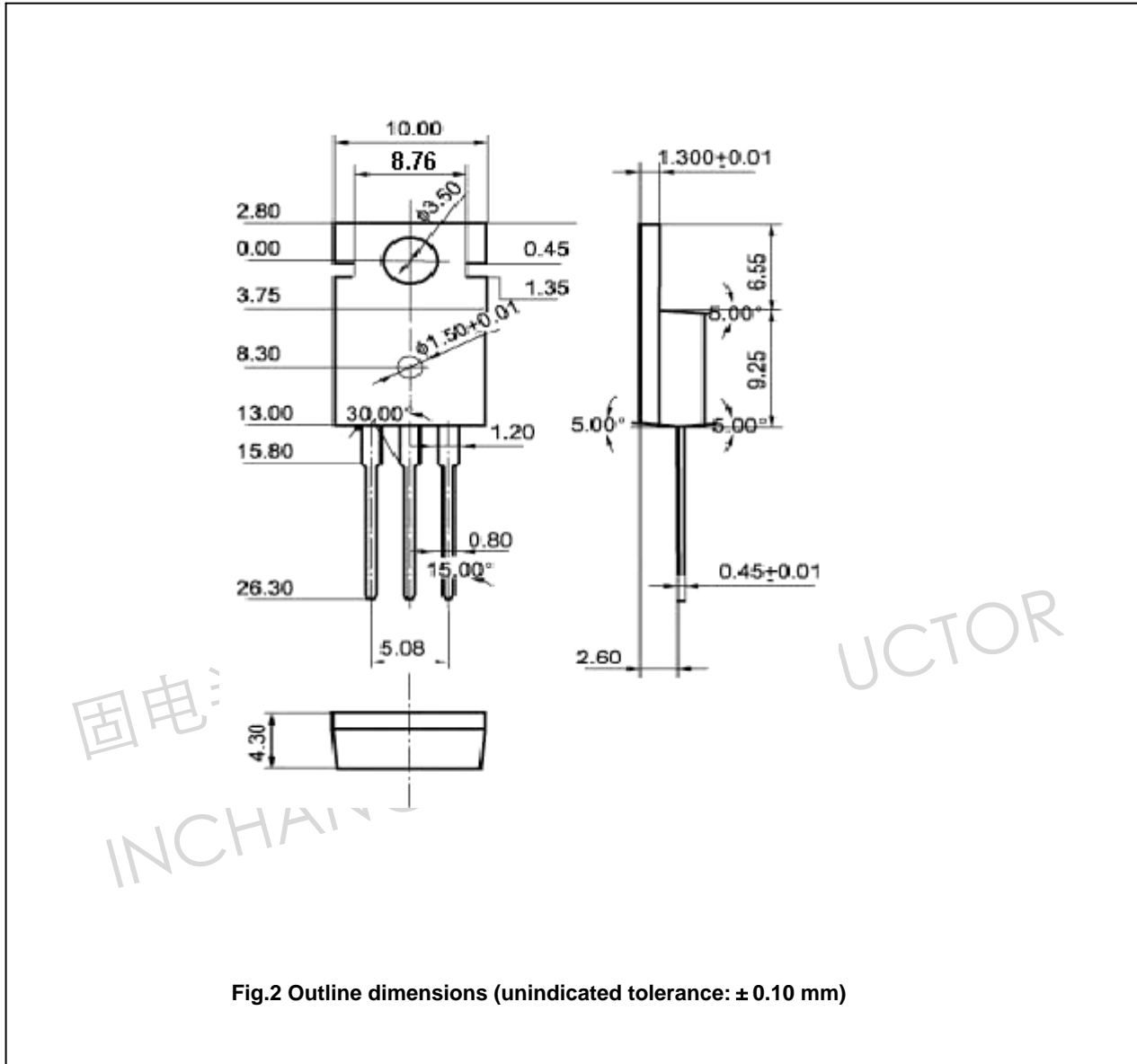

Fig.2 Outline dimensions (unindicated tolerance: ± 0.10 mm)

Silicon NPN Power Transistors

2SC2438

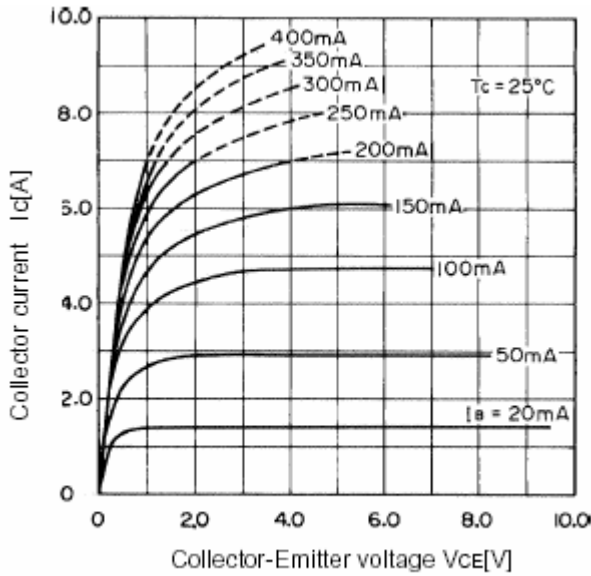

Fig.3 Static Characteristic

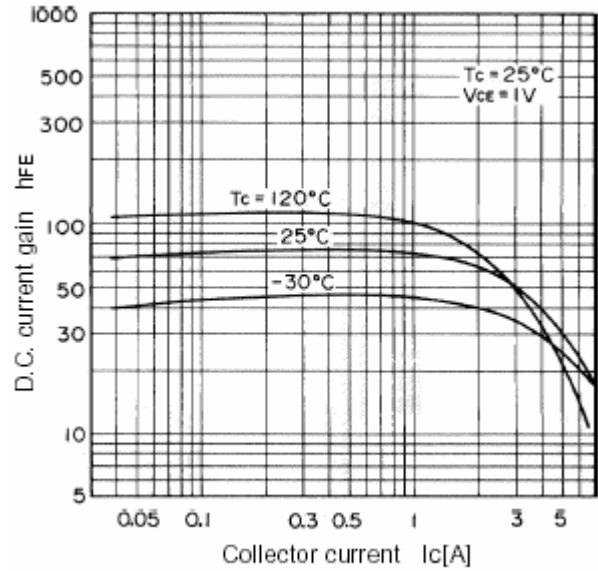

Fig.4 DC current Gain

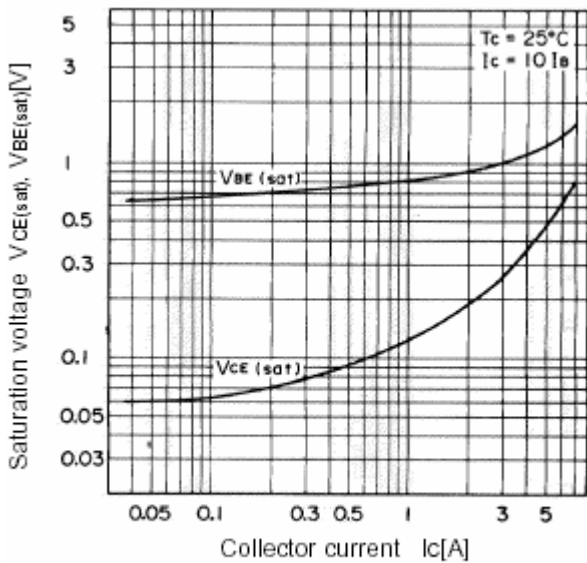

Fig.5 Base-Emitter Saturation Voltage
Collector-Emitter Saturation Voltage

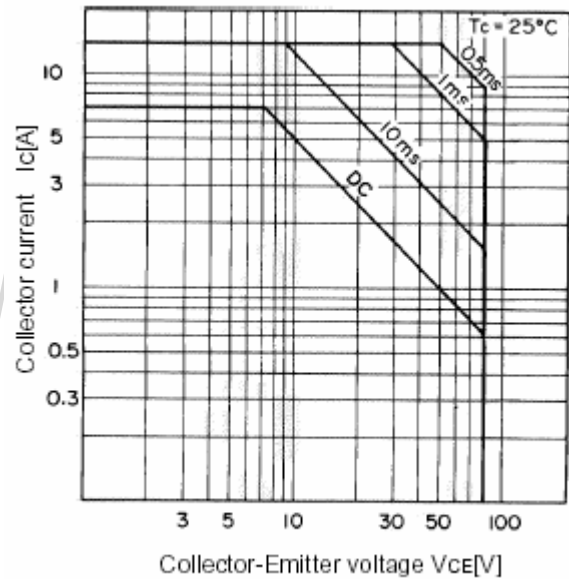

Fig.6 Safe Operating Area