

Inchange Semiconductor

Product Specification

Silicon NPN Power Transistors

2SC2898

DESCRIPTION

- With TO-220C package
- High voltage,high speed
- High power switching

PINNING

PIN	DESCRIPTION
1	Base
2	Collector;connected to mounting base
3	Emitter

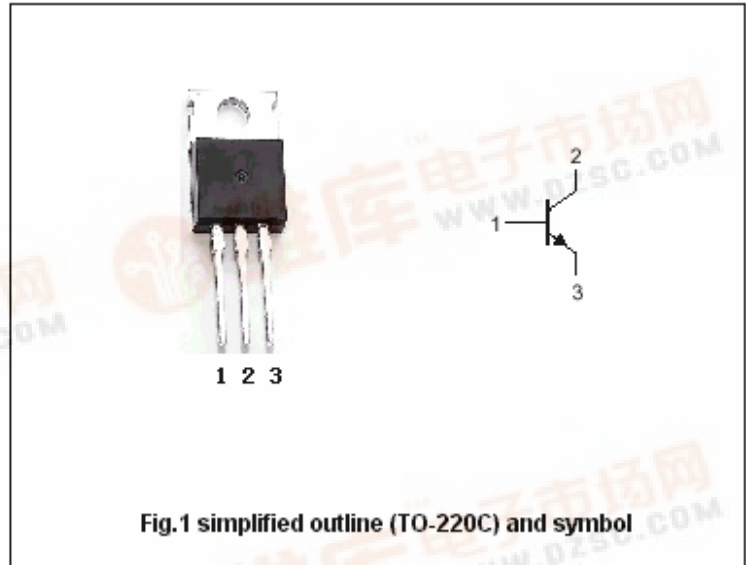

Absolute maximum ratings (Ta=25)

SYMBOL	PARAMETER	CONDITIONS	VALUE	UNIT
V_{CBO}	Collector-base voltage	Open emitter	500	V
V_{CEO}	Collector-emitter voltage	Open base	400	V
V_{EBO}	Emitter-base voltage	Open collector	7	V
I_C	Collector current (DC)		8	A
I_{CM}	Collector current-Peak		16	A
I_B	Base current		4	A
P_C	Collector power dissipation	$T_C=25$	50	W
T_j	Junction temperature		150	
T_{stg}	Storage temperature		-55~150	

Silicon NPN Power Transistors

2SC2898

CHARACTERISTICS

T_j=25 unless otherwise specified

SYMBOL	PARAMETER	CONDITIONS	MIN	TYP.	MAX	UNIT
V _{CEO(SUS)}	Collector-emitter sustaining voltage	I _C =0.2A; L=100mH	400			V
V _{(BR) EBO}	Emitter-base breakdown voltage	I _E =10mA ; I _C =0	7			V
V _{CEsat}	Collector-emitter saturation voltage	I _C =4.0A; I _B =0.8A(pulse test)			1.0	V
V _{BEsat}	Base-emitter saturation voltage	I _C =4.0A; I _B =0.8A(pulse test)			1.5	V
I _{CBO}	Collector cut-off current	V _{CB} =400V; I _E =0			50	μA
I _{CEO}	Collector cut-off current	V _{CE} =350V; R _{BE} =			50	μA
h _{FE-1}	DC current gain	I _C =4A ; V _{CE} =5V(pulse test)	15			
h _{FE-2}	DC current gain	I _C =8A ; V _{CE} =5V(pulse test)	7			

Switching times

t _{on}	Turn-on time	I _C =8A, I _{B1} =-I _{B2} =1.6A V _{CC} 150V			0.8	μs
t _s	Storage time				2.0	μs
t _f	Fall time				0.8	μs

Silicon NPN Power Transistors

2SC2898

PACKAGE OUTLINE

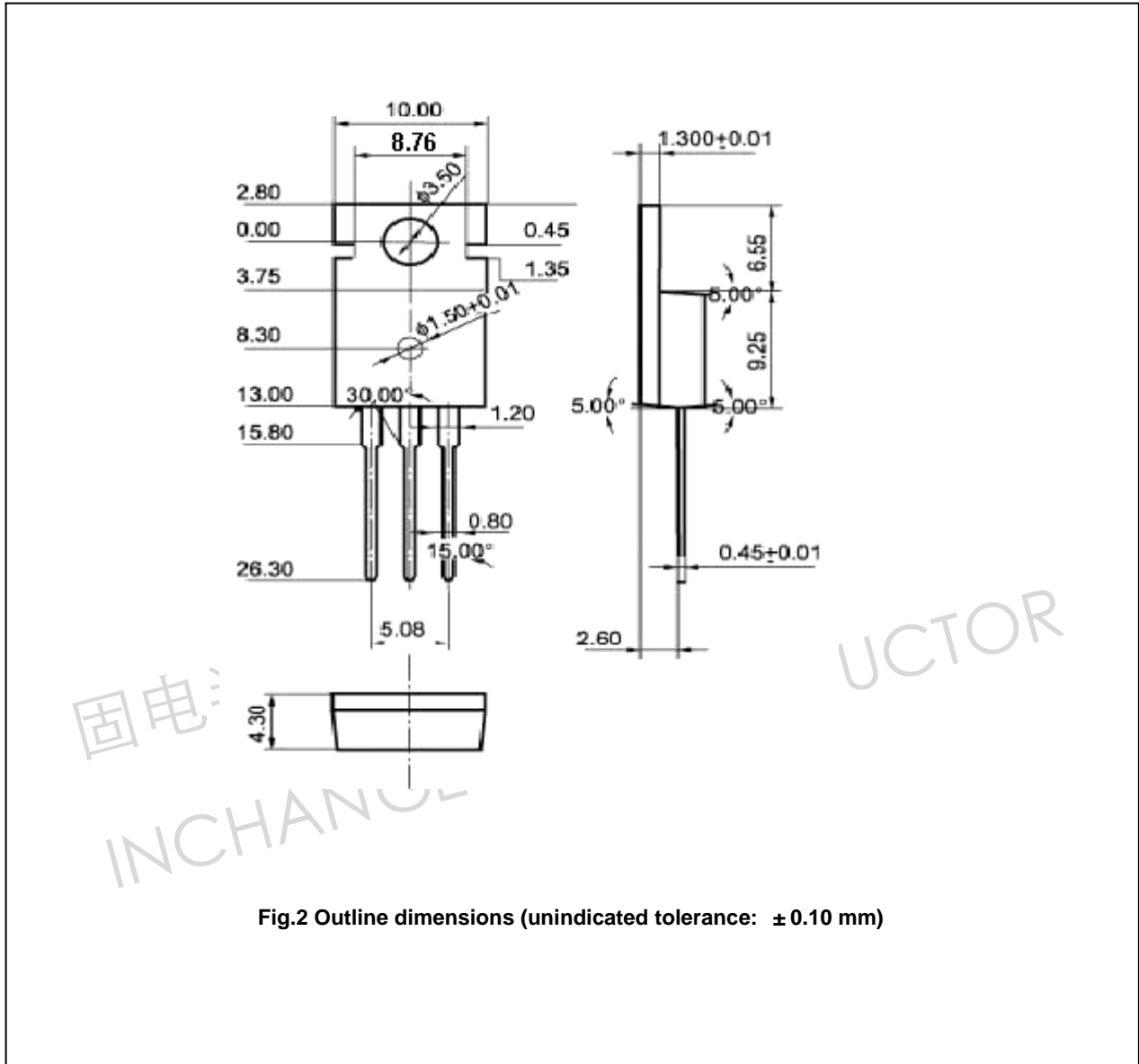

Fig.2 Outline dimensions (unindicated tolerance: ± 0.10 mm)

Silicon NPN Power Transistors

2SC2898

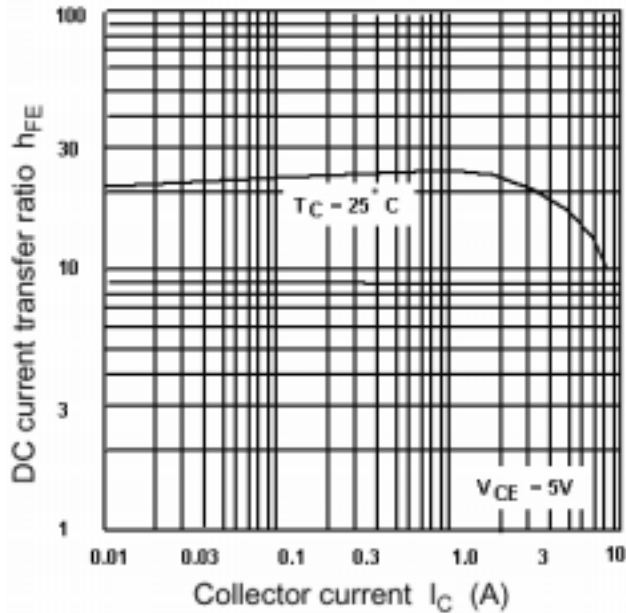

Fig.3 DC current Gain

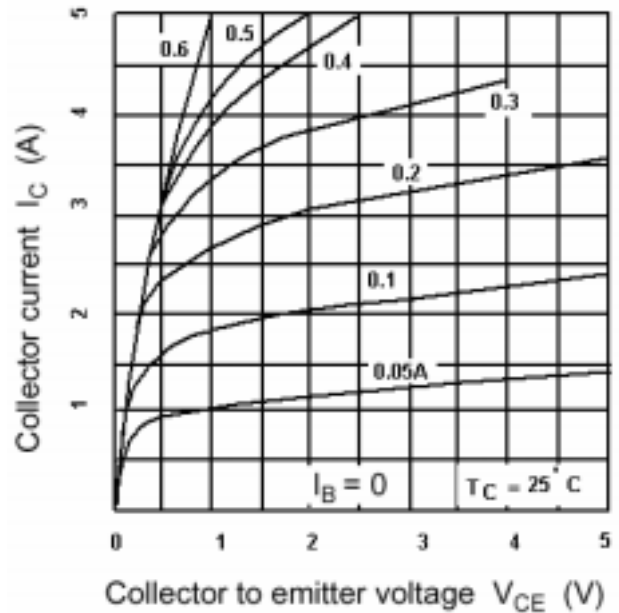

Fig.4 Static Characteristic

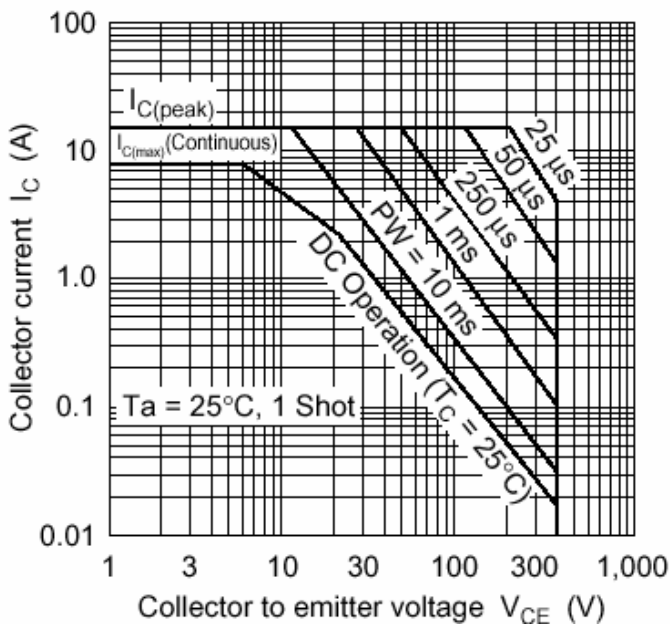

Fig.5 Safe Operating Area

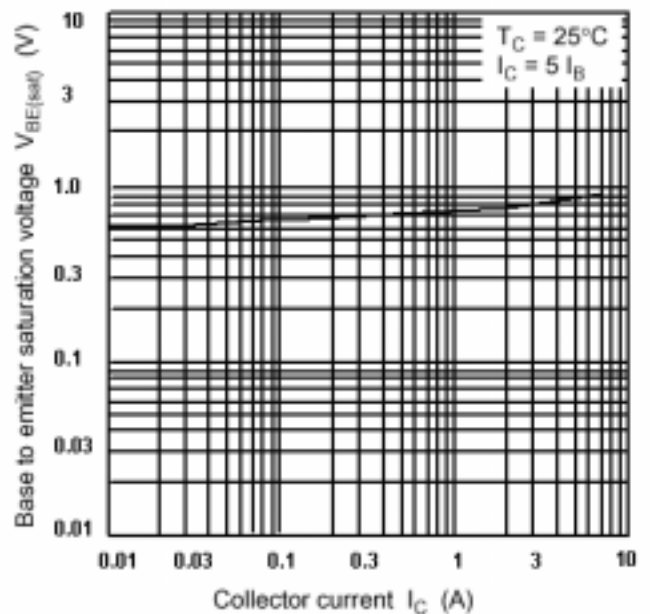

Fig.6 Base-Emitter Saturation Voltage