

Inchange Semiconductor

Product Specification

Silicon NPN Power Transistors

2SC2979

DESCRIPTION

- With TO-220C package
- High V_{CBO}
- Fast switching speed.

APPLICATIONS

- For high voltage ,high speed and high power switching applications

PINNING

PIN	DESCRIPTION
1	Base
2	Collector;connected to mounting base
3	Emitter

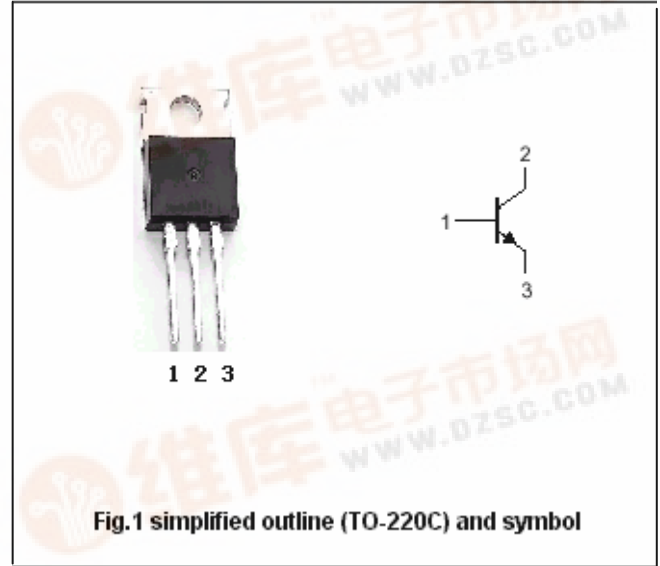

Absolute maximum ratings($T_a=25^\circ C$)

SYMBOL	PARAMETER	CONDITIONS	VALUE	UNIT
V_{CBO}	Collector-base voltage	Open emitter	900	V
V_{CEO}	Collector-emitter voltage	Open base	800	V
V_{EBO}	Emitter-base voltage	Open collector	7	V
I_C	Collector current		3	A
I_{CM}	Collector current-peak		6	A
I_B	Base current		1.5	A
P_C	Collector dissipation	$T_C=25$	40	W
T_j	Junction temperature		150	
T_{stg}	Storage temperature		-55~150	

Silicon NPN Power Transistors

2SC2979

CHARACTERISTICS

T_j=25 unless otherwise specified

SYMBOL	PARAMETER	CONDITIONS	MIN	TYP.	MAX	UNIT
V _{CEO(SUS)}	Collector-emitter sustaining voltage	I _C =0.2A; R _{BE} = ,L=100mH	800			V
V _{(BR)EBO}	Base-emitter breakdown voltage	I _E =10mA ; I _C =0	7			V
V _{CEsat}	Collector-emitter saturation voltage	I _C =0.75A; I _B =0.15A			1.0	V
V _{BEsat}	Base-emitter saturation voltage	I _C =0.75A; I _B =0.15A			1.5	V
I _{CBO}	Collector cut-off current	V _{CB} =750V ; I _E =0			100	μ A
I _{CEO}	Collector cut-off current	V _{CE} =650V; R _{BE} =			100	μ A
h _{FE-1}	DC current gain	I _C =0.3A ; V _{CE} =5V	15			
h _{FE-2}	DC current gain	I _C =1.5A ; V _{CE} =5V	7			

Switching times

t _{on}	Turn-on time	V _{CC} 250V; I _C =1.5A I _{B1} =0.3A; I _{B2} =-0.75A			1.0	μ s
t _{stg}	Storage time				3.0	μ s
t _f	Fall time				1.0	μ s

Silicon NPN Power Transistors

2SC2979

PACKAGE OUTLINE

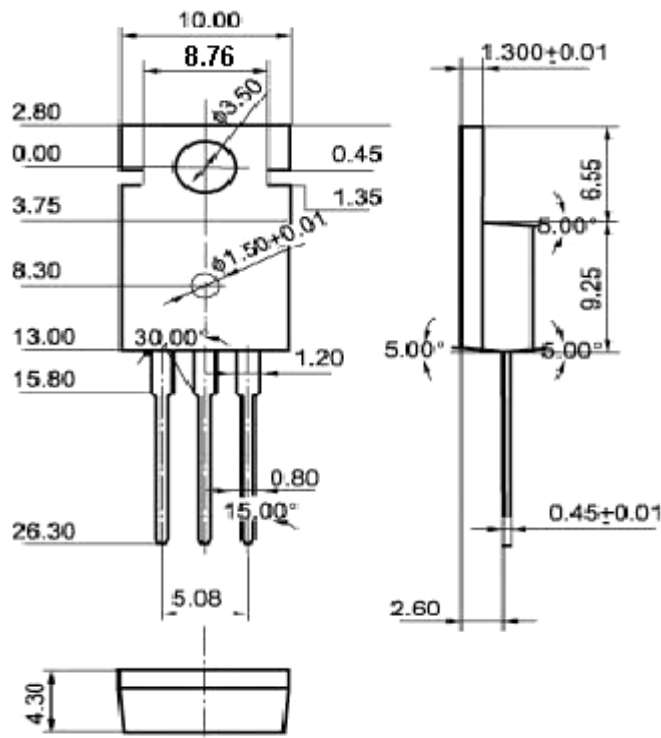

Fig.2 Outline dimensions (unindicated tolerance: ± 0.10 mm)

Silicon NPN Power Transistors

2SC2979

