



LTC4555

SIM Power Supply and Level Translator

FEATURES

- SIM Power Supply: 1.8V/3V at 50mA
- Input Voltage Range: 3V to 6V
- Controller Voltage Range: 1.2V to 4.4V
- 14kV ESD On All SIM Contact Pins
- Meets All ETSI, IMT-2000 and ISO7816 SIM/Smart Card Interface Requirements
- Level Translators to 1.8V or 3V
- 20 μ A Operating Current
- Logic-Controlled Shutdown ($I_{SD} < 1\mu A$)
- Available in a Low Profile, 16-Pin (3mm \times 3mm) QFN Package

APPLICATIONS

- SIM Interface in 3G Cellular Telephones
- Smart Card Readers

DESCRIPTION

The LTC[®]4555 provides power conversion and signal level shifting needed for low voltage 2.5G and 3G cellular telephones to interface with 1.8V or 3V subscriber identity modules (SIMs). The part meets all type approval requirements for 1.8V and 3V SIMs and smart cards. The part contains an LDO linear regulator to supply SIM power at either 1.8V or 3V from a 3V to 6V input. The output voltage is selected with a single pin and up to 50mA of load current can be supplied.

Internal level translators allow controllers operating with supplies as low as 1.2V to interface with 1.8V or 3V smart cards. Battery life is maximized by 20 μ A operating current and <1 μ A shutdown current. Board area is minimized by the 3mm \times 3mm leadless QFN package.

LT, LT, LTC and LTM are registered trademarks of Linear Technology Corporation. All other trademarks are the property of their respective owners.

TYPICAL APPLICATION

Typical SIM Interface

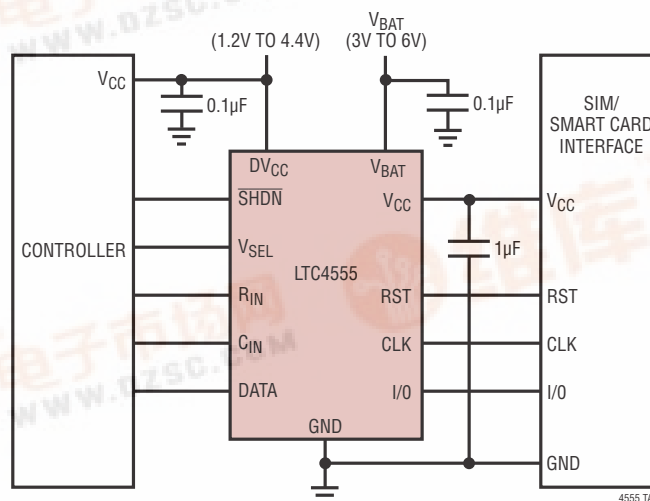

4555 TA01



LTC4555

ABSOLUTE MAXIMUM RATINGS

(Note 1)

V_{BAT} , DV_{CC} , V_{CC} to GND	-0.3V to 6.5V
Digital Inputs to GND	-0.3V to 6.5V
CLK, RST, I/O to GND	-0.3V to $V_{CC} + 0.3V$
V_{CC} Short-Circuit Duration	Infinite
Operating Temperature Range (Note 2)....	-40°C to 85°C
Junction Temperature	125°C
Storage Temperature Range.....	-65°C to 125°C

PIN CONFIGURATION

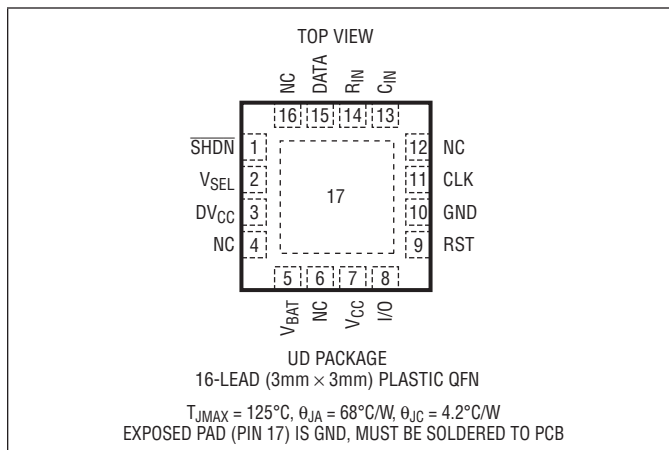

ORDER INFORMATION

LEAD FREE FINISH	TAPE AND REEL	PART MARKING	PACKAGE DESCRIPTION	TEMPERATURE RANGE
LTC4555EUD#PBF	LTC4555EUD#TRPBF	LAAA	16-Lead (3mm x 3mm) Plastic QFN	-40°C to 85°C

Consult LTC Marketing for parts specified with wider operating temperature ranges.

Consult LTC Marketing for information on non-standard lead based finish parts.

For more information on lead free part marking, go to: <http://www.linear.com/leadfree/>

For more information on tape and reel specifications, go to: <http://www.linear.com/tapeandreeel/>

ELECTRICAL CHARACTERISTICS

The ● denotes the specifications which apply over the full operating temperature range, otherwise specifications are at $T_A = 25^\circ\text{C}$.

PARAMETER	CONDITIONS	MIN	TYP	MAX	UNITS
V_{BAT} Operating Voltage	●	3		6	V
V_{BAT} Operating Current	$I_{CC} = 0\text{mA}$ ●		20	30	μA
V_{BAT} Shutdown Current	$\text{SHDN} = 0\text{V}$, $V_{BAT} = 4.5\text{V}$ ●			1	μA
DV_{CC} Operating Voltage	●	1.2		4.4	V
DV_{CC} Operating Current	$f_{CLK} = 1\text{MHz}$ ●		5	10	μA
DV_{CC} Shutdown Current	$\text{SHDN} = 0\text{V}$ ●			1	μA
DV_{CC} Undervoltage Lockout	●	0.5		1.1	V
V_{CC} Output Voltage	$V_{SEL} = DV_{CC}$, $V_{BAT} = 3\text{V}$, $I_{VCC} = 50\text{mA}$		2.8		V
	$V_{SEL} = DV_{CC}$, $V_{BAT} = 3.3\text{V to }6\text{V}$, $I_{VCC} = 0\text{mA to }50\text{mA}$ ●	2.8	3.0	3.2	V
	$V_{SEL} = 0$, $V_{BAT} = 2.6\text{V to }6\text{V}$, $I_{VCC} = 0\text{mA to }50\text{mA}$ ●	1.7	1.8	1.9	V
V_{CC} Short-Circuit Current	V_{CC} Shorted to GND	60	110	175	mA

Controller Inputs/Outputs

Input Voltage Range	SHDN , V_{SEL} , R_{IN} , C_{IN} , DATA		0	DV_{CC}	V
Input Current (I_{IH}/I_{IL})	SHDN , V_{SEL} , R_{IN} , C_{IN} ●	-100		100	nA
High Input Threshold Voltage (V_{IH})	R_{IN} , C_{IN} ●			$0.7 \times DV_{CC}$	V
Low Input Threshold Voltage (V_{IL})	R_{IN} , C_{IN} ●	$0.2 \times DV_{CC}$			V
High Input Threshold Voltage (V_{IH})	SHDN , V_{SEL} ●			1	V
Low Input Threshold Voltage (V_{IL})	SHDN , V_{SEL} ●	0.4			V

ELECTRICAL CHARACTERISTICS

The ● denotes the specifications which apply over the full operating temperature range, otherwise specifications are at $T_A = 25^\circ\text{C}$.

PARAMETER	CONDITIONS		MIN	TYP	MAX	UNITS
High Level Input Current (I_{IH})	DATA	●	-20		20	μA
Low Level Input Current (I_{IL})	DATA	●			1	mA
High Level Output Voltage (V_{OH})	DATA $I_{OH} = 20\mu\text{A}$, $I/O = V_{CC}$	●	$0.7 \times DV_{CC}$			V
Low Level Output Voltage (V_{OL})	DATA $I_{OL} = -200\mu\text{A}$, $I/O = 0\text{V}$	●			0.4	V
DATA Pull-Up Resistance	Between DATA and DV_{CC}		13	20	30	$\text{k}\Omega$
SIM Inputs/Outputs ($V_{CC} = 3\text{V}$)						
High Level Output Voltage (V_{OH})	I/O , $I_{OH} = 20\mu\text{A}$, DATA = DV_{CC}	●	$0.8 \times V_{CC}$			V
Low Level Output Voltage (V_{OL})	I/O , $I_{OL} = -1\text{mA}$, DATA = 0V	●			0.4	V
High Level Output Voltage (V_{OH})	RST, CLK, $I_{OH} = 20\mu\text{A}$	●	$0.9 \times V_{CC}$			V
Low Level Output Voltage (V_{OL})	RST, CLK, $I_{OL} = -200\mu\text{A}$	●			0.4	V
I/O Pull-Up Resistance	Between I/O and V_{CC}		6.5	10	14	$\text{k}\Omega$
SIM Inputs/Outputs ($V_{CC} = 1.8\text{V}$)						
High Level Output Voltage (V_{OH})	I/O , $I_{OH} = 20\mu\text{A}$, DATA = DV_{CC}	●	$0.8 \times V_{CC}$			V
Low Level Output Voltage (V_{OL})	I/O , $I_{OL} = -1\text{mA}$, DATA = 0V	●			0.3	V
High Level Output Voltage (V_{OH})	RST, CLK, $I_{OH} = 20\mu\text{A}$	●	$0.9 \times V_{CC}$			V
Low Level Output Voltage (V_{OL})	RST, CLK, $I_{OL} = -200\mu\text{A}$	●			$0.2 \times V_{CC}$	V
I/O Pull-Up Resistance	Between I/O and V_{CC}		6.5	10	14	$\text{k}\Omega$
SIM Timing Parameters						
CLK Rise/Fall Time	$C_{CLK} = 30\text{pF}$, $V_{CC} = 1.8\text{V}/3\text{V}$	●			18	ns
RST, I/O Rise/Fall Time	RST, I/O Loaded with 30pF , $V_{CC} = 1.8\text{V}/3\text{V}$	●			1	μs
Max CLK Frequency			5			MHz
V_{CC} Turn-On Time	$\overline{\text{SHDN}} = 1$, (Note 3)			0.5		ms
V_{CC} Discharge Time to 1V	$\overline{\text{SHDN}} = 0$, (Note 3)			0.5		ms

Note 1: Stresses beyond those listed under Absolute Maximum Ratings may cause permanent damage to the device. Exposure to any Absolute Maximum Rating condition for extended periods may affect device reliability and lifetime.

Note 2: The LTC4555E is guaranteed to meet performance specifications from 0°C to 85°C . Specifications over the -40°C to 85°C operating temperature range are assured by design, characterization and correlation with statistical process controls.

Note 3: Specification is guaranteed by design and not 100% tested in production.

TYPICAL PERFORMANCE CHARACTERISTICS

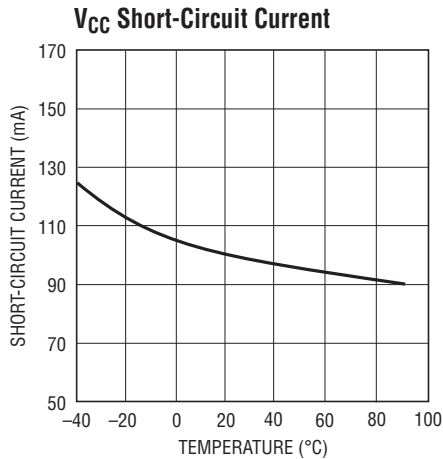

4555 G01

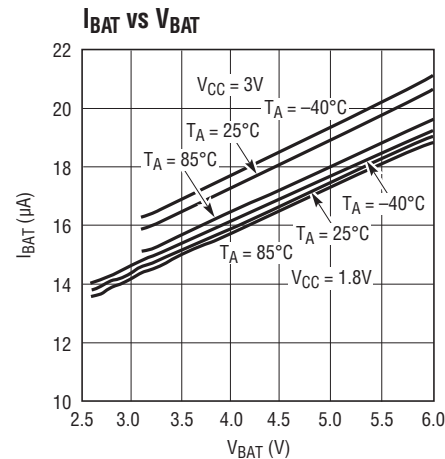

4555 G02

PIN FUNCTIONS

SHDN (Pin 1): Controller Driven Shutdown Pin. This pin should be high (DV_{CC}) for normal operation and low to activate a low current shutdown mode.

V_{SEL} (Pin 2): V_{CC} Voltage Select Pin. A low level selects V_{CC} = 1.8V while driving this pin to DV_{CC} selects V_{CC} = 3V.

DV_{CC} (Pin 3): Supply Voltage for the Controller Side I/O Pins (C_{IN}, R_{IN}, DATA). When below 1.1V, the V_{CC} supply is disabled. This pin should be bypassed with a 0.1µF ceramic capacitor close to the pin.

NC (Pins 4, 6, 12, 16): No Connect.

V_{BAT} (Pin 5): V_{CC} Supply Input. This pin can be between 3V and 6V for normal operation. V_{BAT} quiescent current reduces to <1µA in shutdown. This pin should be bypassed with a 0.1µF ceramic capacitor close to the pin.

V_{CC} (Pin 7): SIM Card V_{CC} Supply. A 1µF low ESR capacitor needs to be connected close to the V_{CC} pin for stable operation. This pin is discharged to GND during shutdown.

I/O (Pin 8): SIM-Side Data I/O. The SIM card output must be on an open-drain driver capable of sourcing >1mA.

RST (Pin 9): Reset Output Pin for the SIM Card.

GND (Pin 10): Ground for the SIM and Controller. Proper grounding and bypassing is required to meet 14kV ESD specifications.

CLK (Pin 11): Clock Output Pin for the SIM Card. This pin is pulled to ground during shutdown. Fast rising and falling edges necessitate careful board layout for the CLK node.

C_{IN} (Pin 13): Clock Input from the Controller.

R_{IN} (Pin 14): Reset Input from the Controller.

DATA (Pin 15): Controller Side Data I/O. This pin is used for bidirectional data transfer. The controller output must be an open-drain configuration. The open-drain output must be capable of sinking greater than 1mA.

Exposed Pad (Pin 17): GND. Must be soldered to PCB.

BLOCK DIAGRAM

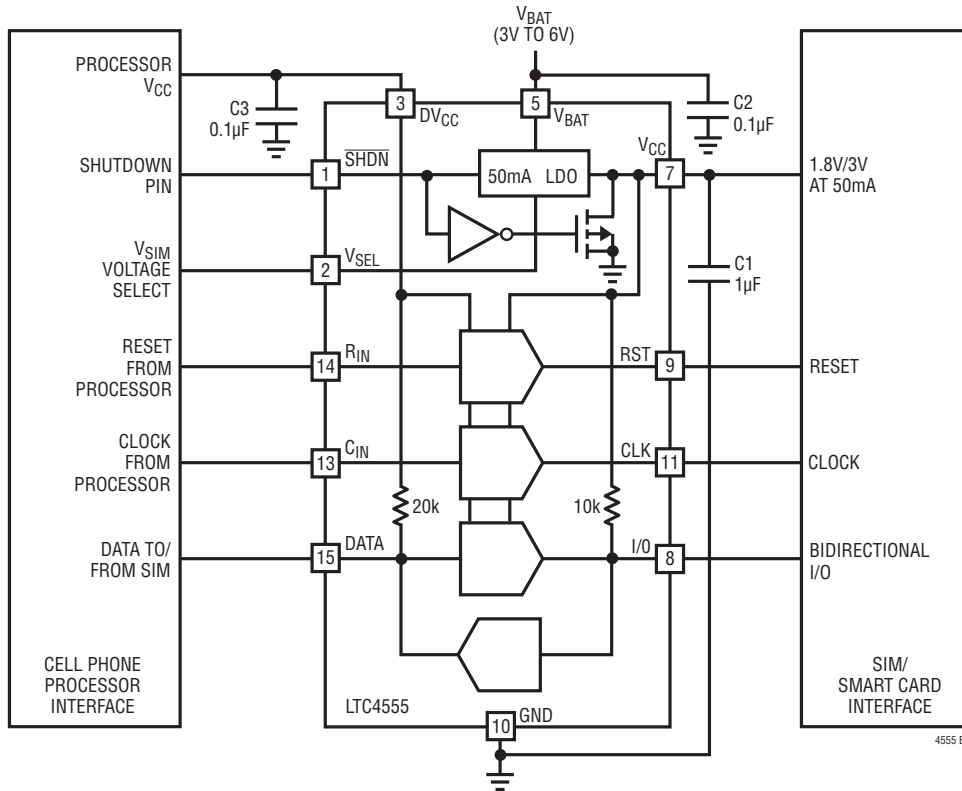

4555 BD

APPLICATIONS INFORMATION

The LTC4555 provides both regulated power and internal level translators to allow low voltage controllers to interface with 1.8V or 3V SIMs or smart cards. The part meets all ETSI, IMT-2000 and ISO7816 requirements for SIM and smart card interfaces.

V_{CC} Voltage Regulator

The V_{CC} voltage regulator is a 50mA low dropout (LDO) regulator with a digitally selected 1.8V or 3V output.

The output voltage is selected via the V_{SEL} pin. The output is internally current limited and is capable of surviving an indefinite short to GND.

The V_{CC} output should be bypassed with a 1μF capacitor. The LTC4555 can use either a low ESR ceramic capacitor or a tantalum electrolytic capacitor on the V_{CC} pin, with no special ESR requirements.

V_{BAT} should be bypassed with a 0.1μF ceramic capacitor.

Level Translators

All SIMs and smart cards contain a clock input, a reset input and a bidirectional data input/output. The LTC4555

provides level translators to allow controllers to communicate with the SIM. The CLK and RST lines to the SIM are level shifted from the controller supply (GND to DV_{CC}) to the SIM supply (GND to V_{CC}). The data input to the SIM requires an open-drain output on the controller. On-chip pull-up resistors are provided for both the DATA and I/O lines.

Shutdown Modes

The LTC4555 enters a low current shutdown mode by pulling the $\overline{\text{SHDN}}$ pin low. The $\overline{\text{SHDN}}$ pin is an active low input that the controller can use to directly shut down the part.

ESD Protection

All pins that connect to the SIM/smart card will withstand 14kV of human body model ESD. In order to ensure proper ESD protection, careful board layout is required. The GND pin should be tied directly to a GND plane. The V_{CC} capacitor should be located very close to the V_{CC} pin and tied directly to the GND plane.

LTC4555

RELATED PARTS

PART NUMBER	DESCRIPTION	COMMENTS
LTC1514	50mA, 650kHz, Step-Up/Down Charge Pump with Low-Battery Comparator	$V_{IN} = 2.7V$ to 10V, $V_{OUT} = 3V/5V$, $I_Q = 60\mu A$, $I_{SD} = 10\mu A$, S8 Package
LTC1515	50mA, 650kHz, Step-Up/Down Charge Pump with Power-On Reset	$V_{IN} = 2.7V$ to 10V, $V_{OUT} = 3.3V$ or 5V, $I_Q = 60\mu A$, $I_{SD} < 1\mu A$, S8 Package
LTC1555/LTC1556	650kHz, SIM Power Supply and Level Translator for 3V/5V SIM Cards	$V_{IN} = 2.7V$ to 10V, $V_{OUT} = 3V/5V$, $I_Q = 60\mu A$, $I_{SD} < 1\mu A$, SSOP-16, SSOP-20 Packages
LTC1555L	1MHz, SIM Power Supply and Level Translator for 3V/5V SIM Cards	$V_{IN} = 2.6V$ to 6.6V, $V_{OUT} = 3V/5V$, $I_Q = 40\mu A$, $I_{SD} < 1\mu A$, SSOP-16 Package
LTC1555L-1.8	1MHz, SIM Power Supply and Level Translator for 1.8V/3V/5V SIM Cards	$V_{IN} = 2.6V$ to 6.6V, $V_{OUT} = 1.8V/3V/5V$, $I_Q = 32\mu A$, $I_{SD} < 1\mu A$, SSOP-16
LTC1755/LTC1756	Smart Card Interface with Serial Control for 3V/5V Smart Card Applications	$V_{IN} = 2.7V$ to 7V, $V_{OUT} = 3V/5V$, $I_Q = 60\mu A$, $I_{SD} < 1\mu A$, SSOP-16, SSOP-24
LTC1955	Dual Smart Card Interface with Serial Control for 1.8V/3V/5V Smart Card Applications	$V_{IN} = 3V$ to 6V, $V_{OUT} = 1.8V/3V$, $I_Q = 200\mu A$, $I_{SD} < 1\mu A$, QFN-32 Package
LTC1986	900kHz, SIM Power Supply for 3V/5V SIM Cards	$V_{IN} = 2.6V$ to 4.4V, $V_{OUT} = 3V/5V$, $I_Q = 14\mu A$, $I_{SD} < 1\mu A$, ThinSOT™ Package
LTC3250-1.5	250mA, 1.5MHz, High Efficiency Step-Down Charge Pump	85% Efficiency, $V_{IN} = 3.1V$ to 5.5V, $V_{OUT} = 1.5V$, $I_Q = 35\mu A$, $I_{SD} < 1\mu A$, ThinSOT Package
LTC3251	500mA, 1MHz to 16MHz, Spread Spectrum, Step-Down Charge Pump	85% Efficiency, $V_{IN} = 3.1V$ to 5.5V, $V_{OUT} = 0.9V$ to 1.6V, $I_Q = 9\mu A$, $I_{SD} < 1\mu A$, MS Package

ThinSOT is a trademark of Linear Technology Corporation.