



# LTC6081/LTC6082

## Precision Dual/Quad CMOS Rail-to-Rail Input/Output Amplifiers

### FEATURES

- **Maximum Offset Voltage: 70 $\mu$ V (25 $^{\circ}$ C)**
- **Maximum Offset Drift: 0.8 $\mu$ V/ $^{\circ}$ C**
- **Maximum Input Bias: 1pA (25 $^{\circ}$ C) 40pA ( $T_A \leq 85^{\circ}$ C)**
- Open Loop Voltage Gain: 120dB Typ
- Gain Bandwidth Product: 3.6MHz
- CMRR: 100dB Min
- PSRR: 98dB Min
- 0.1Hz to 10Hz Noise: 1.3 $\mu$ V<sub>P-P</sub>
- Supply Current: 330 $\mu$ A
- Rail-to-Rail Inputs and Outputs
- Unity Gain Stable
- 2.7V to 5.5V Operation Voltage
- Dual LTC6081 in 8-Lead MSOP and 10-Lead DFN10 Packages; Quad LTC6082 in 16-Lead SSOP and DFN Packages

### APPLICATIONS

- Photodiode Amplifier
- Strain Gauge
- High Impedance Sensor Amplifier
- Microvolt Accuracy Threshold Detection
- Instrumentation Amplifiers
- Thermocouple Amplifiers

### DESCRIPTION

The LTC<sup>®</sup>6081/LTC6082 are dual/quad low offset, low drift, low noise CMOS operational amplifiers with rail-to-rail input/output swing.

The 70 $\mu$ V maximum offset, 1pA input bias current, 120dB open loop gain and 1.3 $\mu$ V<sub>P-P</sub> 0.1Hz to 10Hz noise make it perfect for precision signal conditioning. The LTC6081/LTC6082 features 100dB CMRR and 98dB PSRR.

Each amplifier consumes only 330 $\mu$ A of current on a 3V supply. The 10-lead DFN has an independent shutdown function that reduces each amplifier's supply current to 1 $\mu$ A.

LTC6081/LTC6082 is specified for power supply voltages of 3V and 5V from -40 $^{\circ}$ C to 125 $^{\circ}$ C. The dual LTC6081 is available in 8-lead MSOP and 10-lead DFN10 packages. The quad LTC6082 is available in 16-lead SSOP and DFN packages.

**LT**, LTC, LT and LTM are registered trademarks of Linear Technology Corporation. All other trademarks are the property of their respective owners.

### TYPICAL APPLICATION

Shock Sensor Amplifier (Accelerometer)

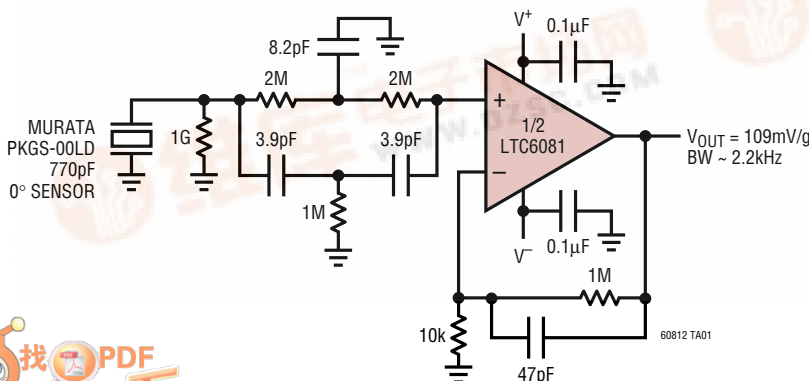

V<sub>OS</sub> Drift Histogram

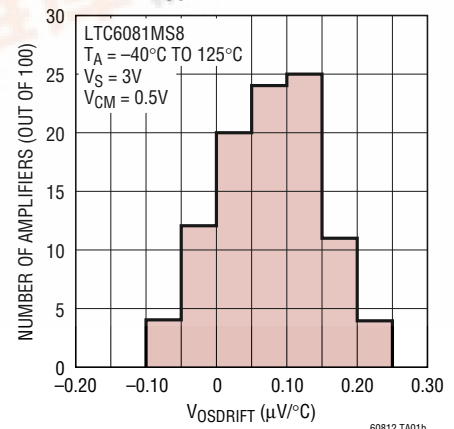

# LTC6081/LTC6082

## ABSOLUTE MAXIMUM RATINGS

(Note 1)

Total Supply Voltage ( $V^+$ to $V^-$ ) .....	6V
Input Voltage .....	$V^-$ to $V^+$
Output Short Circuit Duration (Note 2) .....	Indefinite
Operating Temperature Range (Note 3)	
LTC6081C, LTC6082C .....	-40°C to 85°C
LTC6081I, LTC6082I .....	-40°C to 85°C
LTC6081H, LTC6082H .....	-40°C to 125°C
(H Temperature Range Not Available in DFN Package)	

Specified Temperature Range (Note 4)	
LTC6081C, LTC6082C .....	0°C to 70°C
LTC6081I, LTC6082I .....	-40°C to 85°C
LTC6081H, LTC6082H .....	-40°C to 125°C
Junction Temperature	
DFN Packages .....	125°C
All Other Packages .....	150°C
Storage Temperature Range	
DFN Packages .....	-65°C to 125°C
All Other Packages .....	-65°C to 150°C
Lead Temperature (Soldering, 10 Sec) .....	300°C

## PIN CONFIGURATION

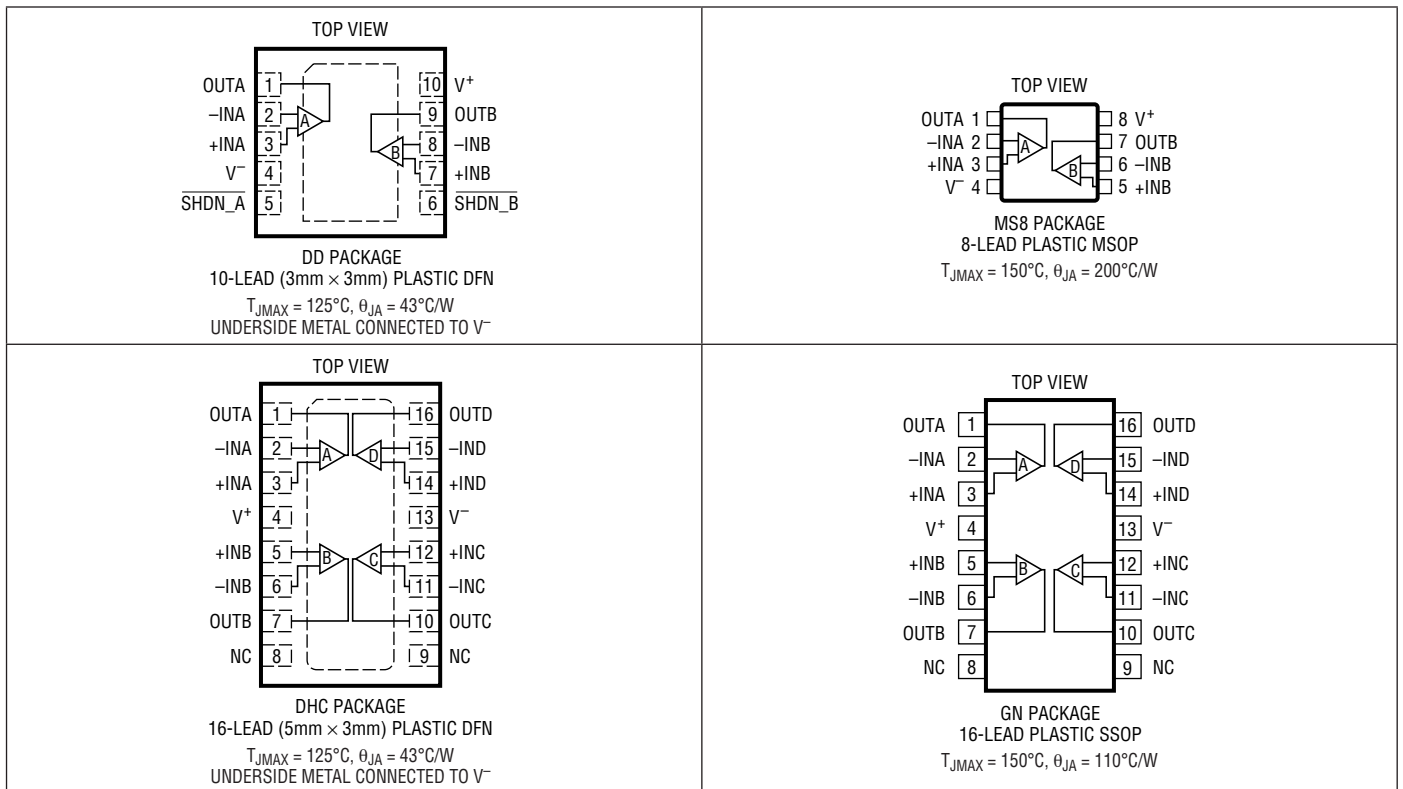

## ORDER INFORMATION

LTC6081	C	DD	#	TR	PBF
					<b>LEAD FREE DESIGNATOR</b> PBF = Lead Free Blank = Lead Tin Lead Finish
					<b>TAPE AND REEL</b> TR = Tape and Reel Blank = Bulk
					<b>NUMBER SIGN</b> Required before Tape and Reel and Lead Free Orders
					<b>PACKAGE TYPE</b> DD = 10-Lead (3mm × 3mm) Plastic DFN DHC = 16-Lead (5mm × 3mm) Plastic DFN GN = 16-Lead Plastic SSOP MS8 = 8-Lead Plastic MSOP
					<b>TEMPERATURE GRADE</b> C = Commercial Temperature Range (0°C to 70°C) I = Industrial Temperature Range (-40°C to 85°C) H = High Temperature Range (-40°C to 125°C) (H grade not available for DD or DHC package)
					<b>PRODUCT PART NUMBER</b> LTC6081 (Precision Dual Amplifier) LTC6082 (Precision Quad Amplifier)

Consult LTC Marketing for parts specified with wider operating temperature ranges.

Consult LTC Marketing for information on non-standard lead based finish parts.

For more information on lead free part marking, go to: <http://www.linear.com/leadfree/>

For more information on tape and reel specifications, go to: <http://www.linear.com/tapeandree/>

# LTC6081/LTC6082

**ELECTRICAL CHARACTERISTICS** The ● denotes the specifications which apply over the full operating temperature range, otherwise specifications are at  $T_A = 25^\circ\text{C}$ . Test conditions are  $V^+ = 3\text{V}$ ,  $V^- = 0\text{V}$ ,  $V_{\text{CM}} = 0.5\text{V}$  unless otherwise noted.

SYMBOL	PARAMETER	CONDITIONS	C, I SUFFIXES			H SUFFIX			UNITS
			MIN	TYP	MAX	MIN	TYP	MAX	
$V_{\text{OS}}$	Offset Voltage	LTC6081MS8, LTC6082GN		-70	70	-70	70	$\mu\text{V}$	
		LTC6081MS8, LTC6082GN	●	-90	90	-90	90	$\mu\text{V}$	
		LTC6081DD, LTC6082DHC		-70	70			$\mu\text{V}$	
		LTC6081DD, LTC6082DHC	●	-90	90			$\mu\text{V}$	
$\Delta V_{\text{OS}}/\Delta T$	Input Offset Voltage Drift (Note 5)		●	$\pm 0.2$	$\pm 0.8$	$\pm 0.2$	$\pm 0.8$	$\mu\text{V}/^\circ\text{C}$	
$I_{\text{B}}$	Input Bias Current (Note 6)		●	0.2	1	0.2	1	$\text{pA}$	
					40		500	$\text{pA}$	
$I_{\text{OS}}$	Input Offset Current		●	0.1		0.1		$\text{pA}$	
					15		100	$\text{pA}$	
$e_{\text{n}}$	Input Referred Noise	Noise Density at $f = 1\text{kHz}$		13		13		$\text{nV}/\sqrt{\text{Hz}}$	
		Integrated Noise From 0.1Hz to 10Hz		1.3		1.3		$\mu\text{V}_{\text{P-P}}$	
$I_{\text{n}}$	Input Noise Current Density (Note 7)			0.5		0.5		$\text{fA}/\sqrt{\text{Hz}}$	
		Input Common Mode Range	●	$V^-$	$V^+$	$V^-$	$V^+$	V	
$C_{\text{DIFF}}$	Differential Input Capacitance			3		3		pF	
$C_{\text{CM}}$	Common Mode Input Capacitance			7		7		pF	
CMRR	Common Mode Rejection Ratio	$V_{\text{CM}} = 0\text{V}$ to 1.5V	●	95	105	95	105	dB	
		$V_{\text{CM}} = 0\text{V}$ to 1.5V		88	100	86	100	dB	
		$V_{\text{CM}} = 0\text{V}$ to 3V		93	105	93	105	dB	
		$V_{\text{CM}} = 0\text{V}$ to 3V	●	88	100	86	100	dB	
PSRR	Power Supply Rejection Ratio	$V_{\text{S}} = 2.7\text{V}$ to 5.5V	●	98	110	98	110	dB	
$V_{\text{OUT}}$	Output Voltage, High, Either Output Pin	No Load	●		1		1	mV	
		$I_{\text{SOURCE}} = 0.5\text{mA}$	●	-32		-35		mV	
	$I_{\text{SOURCE}} = 5\text{mA}$	●	-320		-350		mV		
	Output Voltage, Low, Either Output Pin (Referred to $V^-$ )	No Load	●		1		1	mV	
$I_{\text{SINK}} = 0.5\text{mA}$		●			33		40	mV	
$I_{\text{SINK}} = 5\text{mA}$	●			300		360	mV		
$A_{\text{VOL}}$	Large-Signal Voltage Gain	$R_{\text{LOAD}} = 10\text{k}\Omega$ , $0.5\text{V} < V_{\text{OUT}} < 2.5\text{V}$	●	110	120	110	120	dB	
$I_{\text{SC}}$	Output Short-Circuit Current	Source	●	17		15		mA	
		Sink	●	17		15		mA	
SR	Slew Rate	$A_{\text{V}} = 1$		1		1		$\text{V}/\mu\text{s}$	
GBW	Gain-Bandwidth Product ( $f_{\text{TEST}} = 50\text{kHz}$ )		●	2.5	3.6	2.5	3.6	MHz	
				1.8		1.5		MHz	
$\Phi_0$	Phase Margin	$R_{\text{L}} = 10\text{k}\Omega$		70		70		Deg	
$t_{\text{S}}$	Settling Time 0.1%	$A_{\text{V}} = 1$ , 1V Step		6		6		$\mu\text{s}$	
$I_{\text{S}}$	Supply Current (Per Amplifier)	No Load	●	330	400	330	400	$\mu\text{A}$	
					435		460	$\mu\text{A}$	
$I_{\text{S}}$	Shutdown Current (Per Amplifier)	Shutdown, $V_{\text{SHDN}} \leq 0.8\text{V}$	●	0.5				$\mu\text{A}$	
					2			$\mu\text{A}$	
$V_{\text{S}}$	Supply Voltage Range	Guaranteed by the PSRR Test	●	2.7	5.5	2.7	5.5	V	
		Channel Separation			-120		-120	dB	
		$f_{\text{S}} = 10\text{kHz}$ , $R_{\text{L}} = 10\text{k}\Omega$						dB	

## ELECTRICAL CHARACTERISTICS

The ● denotes the specifications which apply over the full operating temperature range, otherwise specifications are at  $T_A = 25^\circ\text{C}$ . Test conditions are  $V^+ = 3\text{V}$ ,  $V^- = 0\text{V}$ ,  $V_{\text{CM}} = 0.5\text{V}$  unless otherwise noted.

SYMBOL	PARAMETER	CONDITIONS	C, I SUFFIXES			H SUFFIX			UNITS	
			MIN	TYP	MAX	MIN	TYP	MAX		
	Shutdown Logic	$\overline{\text{SHDN}}$ High $\overline{\text{SHDN}}$ Low	●	2		0.8	2		0.8	V V
THD	Total Harmonic Distortion	$f = 10\text{kHz}$ , $V^+ = 3\text{V}$ , $V_{\text{OUT}} = 1\text{V}_{\text{P-P}}$ , $R_L = 10\text{k}$			-90			-90		dB
$t_{\text{ON}}$	Turn-On Time	$V_{\overline{\text{SHDN}}} = 0.8\text{V to } 2\text{V}$			10			10		$\mu\text{s}$
$t_{\text{OFF}}$	Turn-Off Time	$V_{\overline{\text{SHDN}}} = 2\text{V to } 0.8\text{V}$			2			2		$\mu\text{s}$
	$\overline{\text{SHDN}}$ Pin Current	$V_{\overline{\text{SHDN}}} = 0\text{V}$	●			2				$\mu\text{A}$

The ● denotes the specifications which apply over the full operating temperature range, otherwise specifications are at  $T_A = 25^\circ\text{C}$ . Test conditions are  $V^+ = 5\text{V}$ ,  $V^- = 0\text{V}$ ,  $V_{\text{CM}} = 0.5\text{V}$  unless otherwise noted.

SYMBOL	PARAMETER	CONDITIONS	C, I SUFFIXES			H SUFFIX			UNITS		
			MIN	TYP	MAX	MIN	TYP	MAX			
$V_{\text{OS}}$	Offset Voltage	LTC6081MS8, LTC6082GN	●	-70		70	-70		70	$\mu\text{V}$	
		LTC6081MS8, LTC6082GN	●	-90		90	-90		90	$\mu\text{V}$	
		LTC6081DD, LTC6082DHC	●	-70		70				$\mu\text{V}$	
		LTC6081DD, LTC6082DHC	●	-90		90				$\mu\text{V}$	
$\Delta V_{\text{OS}}/\Delta T$	Input Offset Voltage Drift (Note 8)		●	$\pm 0.2$		$\pm 0.8$	$\pm 0.2$		$\pm 0.8$	$\mu\text{V}/^\circ\text{C}$	
$I_{\text{B}}$	Input Bias Current		●	0.2		40	0.2		500	pA pA	
$I_{\text{OS}}$	Input Offset Current		●	0.1		15	0.1		100	pA pA	
$e_{\text{n}}$	Input Referred Noise	$f = 1\text{kHz}$			13			13		$\text{nV}/\sqrt{\text{Hz}}$	
		0.1Hz to 10Hz			1.3			1.3		$\mu\text{V}_{\text{P-P}}$	
$I_{\text{n}}$	Input Noise Current Density (Note 7)				0.5			0.5		$\text{fA}/\sqrt{\text{Hz}}$	
	Input Common Mode Range		●	$V^-$		$V^+$	$V^-$		$V^+$	V	
$C_{\text{DIFF}}$	Differential Input Capacitance				3			3		pF	
$C_{\text{CM}}$	Common Mode Input Capacitance				7			7		pF	
CMRR	Common Mode Rejection Ratio	$V_{\text{CM}} = 0\text{V to } 3.5\text{V}$	●	100		110	100		110	dB	
		$V_{\text{CM}} = 0\text{V to } 3.5\text{V}$	●	95		110	94		110	dB	
		$V_{\text{CM}} = 0\text{V to } 5\text{V}$	●	86		95	86		95	dB	
PSRR	Power Supply Rejection Ratio	$V_{\text{S}} = 2.7\text{V to } 5.5\text{V}$	●	98		110	98		110	dB	
			●	96			96			dB	
$V_{\text{OUT}}$	Output Voltage, High, Either Output Pin (Referred to $V^+$ )	No Load	●			1			1	mV	
		$I_{\text{SOURCE}} = 0.5\text{mA}$	●	-24			-25			mV	
		$I_{\text{SOURCE}} = 5\text{mA}$	●	-200			-220			mV	
$V_{\text{OUT}}$	Output Voltage, Low, Either Output Pin (Referred to $V^-$ )	No Load	●			1			1	mV	
		$I_{\text{SINK}} = 0.5\text{mA}$	●							32	mV
		$I_{\text{SINK}} = 5\text{mA}$	●			27			240	mV	
$A_{\text{VOL}}$	Large-Signal Voltage Gain	$R_{\text{LOAD}} = 10\text{k}$ , $0.5\text{V} < V_{\text{OUT}} < 4.5\text{V}$	●	110		120	110		120	dB	

# LTC6081/LTC6082

## ELECTRICAL CHARACTERISTICS

The ● denotes the specifications which apply over the full operating temperature range, otherwise specifications are at  $T_A = 25^\circ\text{C}$ . Test conditions are  $V^+ = 5\text{V}$ ,  $V^- = 0\text{V}$ ,  $V_{\text{CM}} = 0.5\text{V}$  unless otherwise noted.

SYMBOL	PARAMETER	CONDITIONS	C, I SUFFIXES			H SUFFIX			UNITS
			MIN	TYP	MAX	MIN	TYP	MAX	
$I_{\text{SC}}$	Output Short-Circuit Current	Source Sink	●	24			21		mA
			●	24			21		mA
SR	Slew Rate	$A_V = 1$		1		1		V/ $\mu\text{s}$	
GBW	Gain-Bandwidth Product ( $f_{\text{TEST}} = 50\text{kHz}$ )	$R_L = 100\text{k}$	●	2.5	3.5		2.5	3.5	MHz
				1.8			1.5		MHz
$\Phi_0$	Phase Margin	$R_L = 10\text{k}$		70		70		Deg	
$t_S$	Settling Time 0.1%	$A_V = 1$ , 1V Step		6		6		$\mu\text{s}$	
$I_S$	Supply Current (Per Amplifier)	No Load	●	340	425		340	425	$\mu\text{A}$
					465		490		$\mu\text{A}$
	Shutdown Current (Per Amplifier)	Shutdown, $V_{\text{SHDN}} \leq 1.2\text{V}$	●		6			$\mu\text{A}$	
$V_S$	Supply Voltage Range	Guaranteed by the PSRR Test	●	2.7	5.5		2.7	5.5	V
	Channel Separation	$f_S = 10\text{kHz}$ , $R_L = 10\text{k}$		-120		-120		dB	
	Shutdown Logic	SHDN High SHDN Low	●	3.5			3.5		V
			●		1.2			1.2	V
THD	Total Harmonic Distortion	$f = 10\text{kHz}$ , $V^+ = 5\text{V}$ , $V_{\text{OUT}} = 2\text{V}_{\text{P-P}}$ , $R_L = 10\text{k}$		-90		-90		dB	
$t_{\text{ON}}$	Turn-On Time	$V_{\text{SHDN}} = 1.2\text{V}$ to $3.5\text{V}$		10		10		$\mu\text{s}$	
$t_{\text{OFF}}$	Turn-Off Time	$V_{\text{SHDN}} = 3.5\text{V}$ to $1.2\text{V}$		2		2		$\mu\text{s}$	
	SHDN Pin Current	$V_{\text{SHDN}} = 0\text{V}$	●		2			$\mu\text{A}$	

**Note 1:** Stresses beyond those listed under Absolute Maximum Ratings may cause permanent damage to the device. Exposure to any Absolute Maximum Rating condition for extended periods may affect device reliability and lifetime.

**Note 2:** A heat sink may be required to keep the junction temperature below the absolute maximum. This depends on the power supply voltage and how many amplifiers are shorted.

**Note 3:** The LTC6081C/LTC6082C and LTC6081I/LTC6082I are guaranteed functional over the operating temperature range of  $-40^\circ\text{C}$  to  $85^\circ\text{C}$ . The LTC6081H/LTC6082H are guaranteed functional over the operating temperature range of  $-40^\circ\text{C}$  to  $125^\circ\text{C}$ .

**Note 4:** The LTC6081C/LTC6082C are guaranteed to meet specified performance from  $0^\circ\text{C}$  to  $70^\circ\text{C}$ . The LTC6081C/LTC6082C are designed,

characterized and expected to meet specified performance from  $-40^\circ\text{C}$  to  $85^\circ\text{C}$  but are not tested or QA sampled at these temperatures. The LTC6081I/LTC6082I are guaranteed to meet specified performance from  $-40^\circ\text{C}$  to  $85^\circ\text{C}$ . The LTC6081H/LTC6082H are guaranteed to meet specified performance from  $-40^\circ\text{C}$  to  $125^\circ\text{C}$ .

**Note 5:** Input offset drift is computed from the limits of the  $V_{\text{OS}}$  test divided by the temperature range. This is a conservative estimate of worst case drift. Consult the Typical Performance Characteristics section for more information on input offset drift.

**Note 6:**  $I_B$  guaranteed by the  $V_S = 5\text{V}$  test.

**Note 7:** Current noise is calculated from  $I_n = \sqrt{2qI_B}$ , where  $q = 1.6 \cdot 10^{-19}$  coulomb.

**Note 8:**  $V_{\text{OS}}$  drift is guaranteed by the  $V_S = 3\text{V}$  test.

# TYPICAL PERFORMANCE CHARACTERISTICS

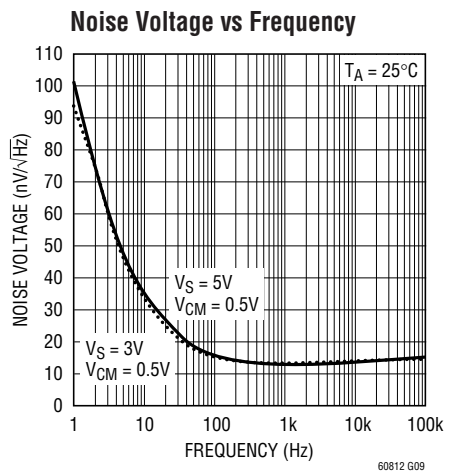
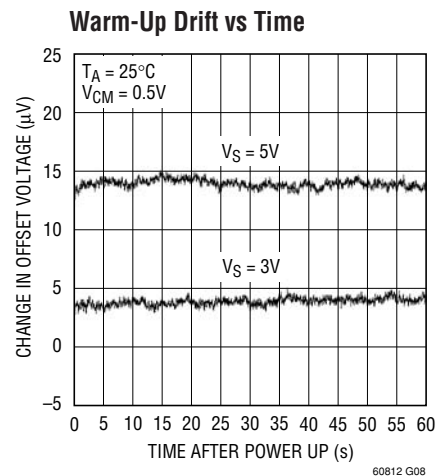
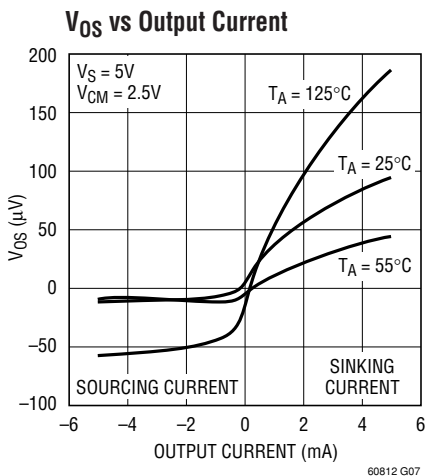
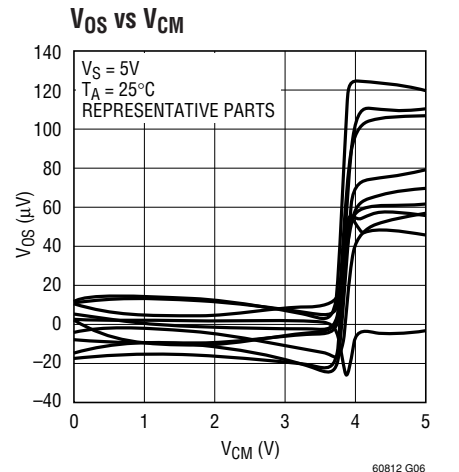
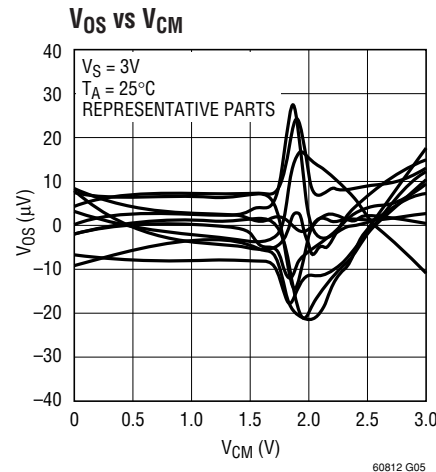
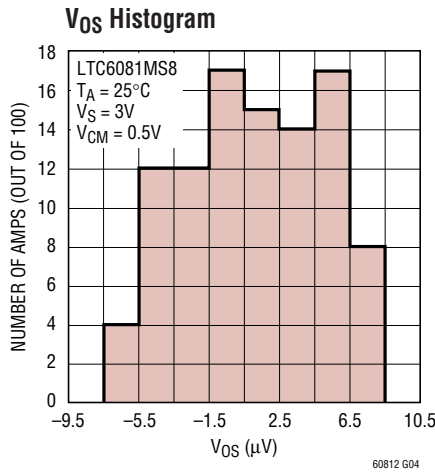
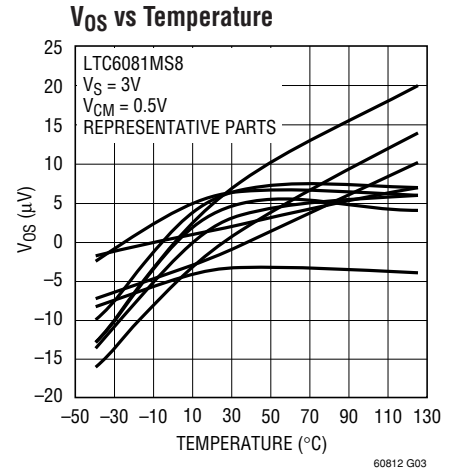
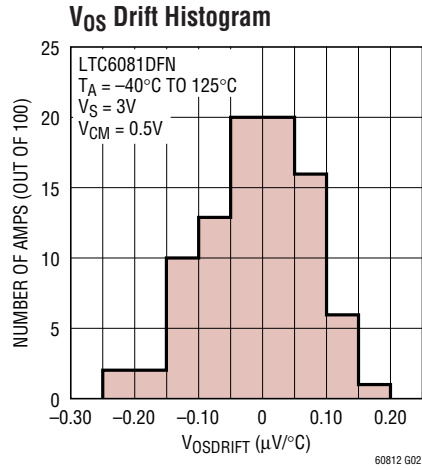
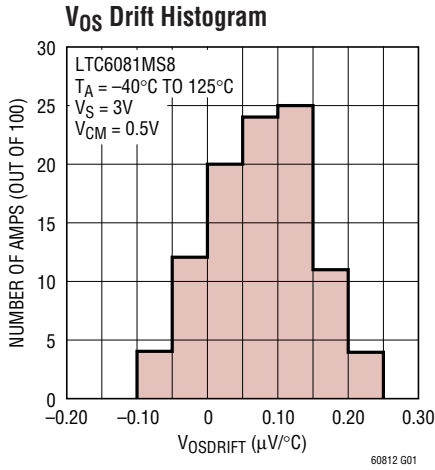

# LTC6081/LTC6082

## TYPICAL PERFORMANCE CHARACTERISTICS

**Noise Voltage vs Frequency**

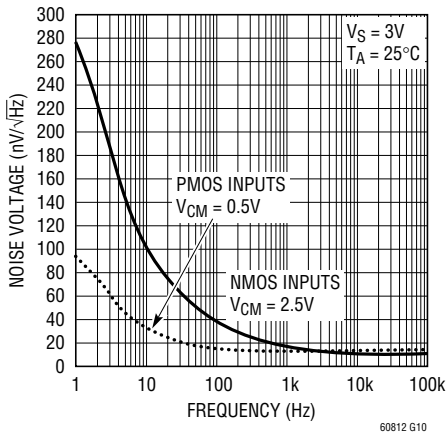

60812 G10

**0.1Hz to 10Hz Output Voltage Noise**

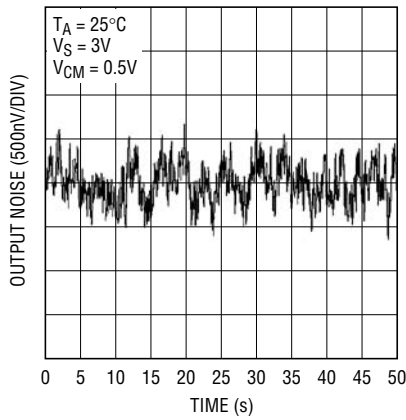

60812 G11

**0.1Hz to 10Hz Output Voltage Noise**

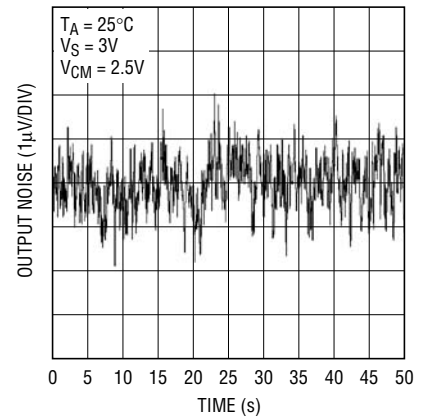

60812 G12

**Input Bias Current vs Temperature**

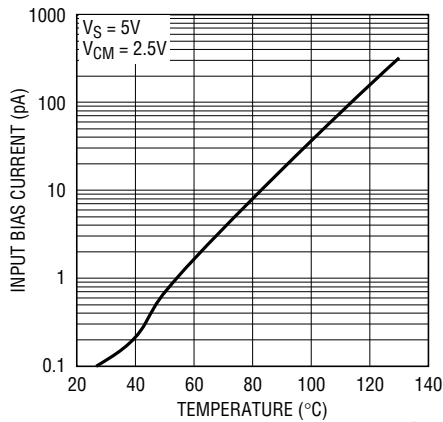

60812 G13

**I<sub>BIAS</sub> vs V<sub>CM</sub>**

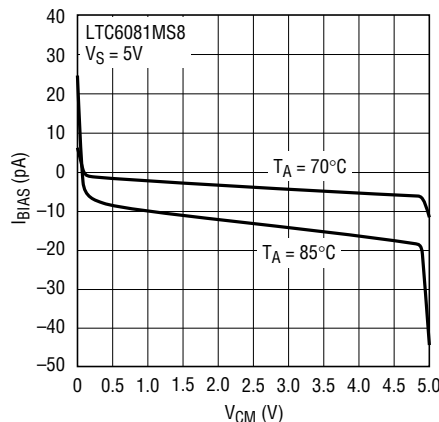

60812 G14

**I<sub>BIAS</sub> vs V<sub>CM</sub>**

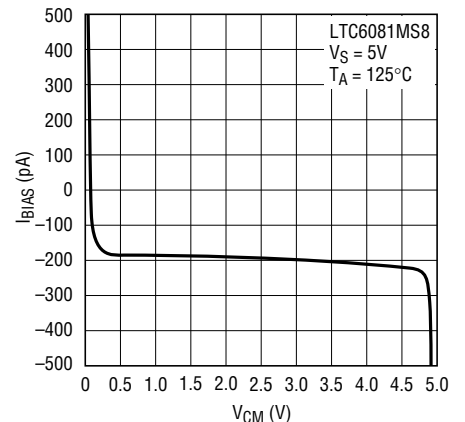

60812 G15

**Large Signal Transient**

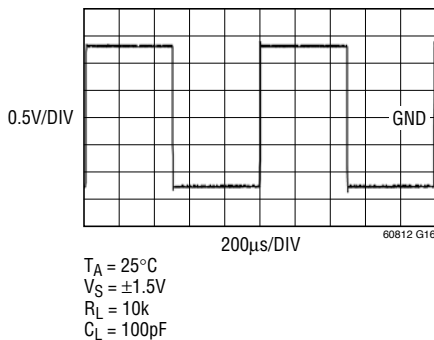

60812 G16

**Small Signal Transient**

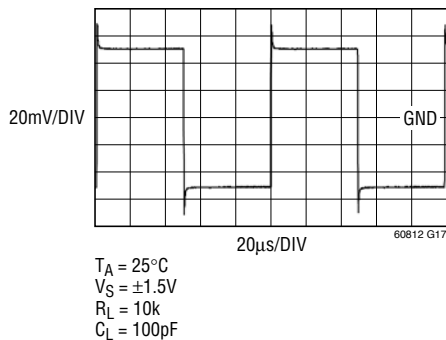

60812 G17

**Overshoot vs C<sub>L</sub>**

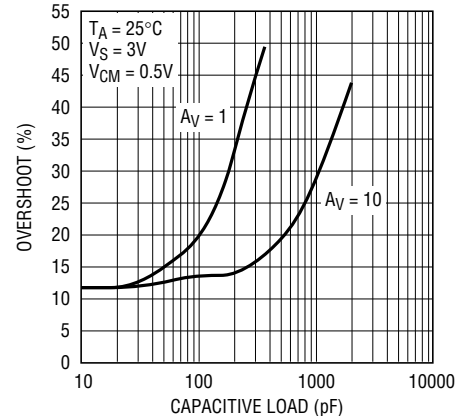

60812 G18



# TYPICAL PERFORMANCE CHARACTERISTICS

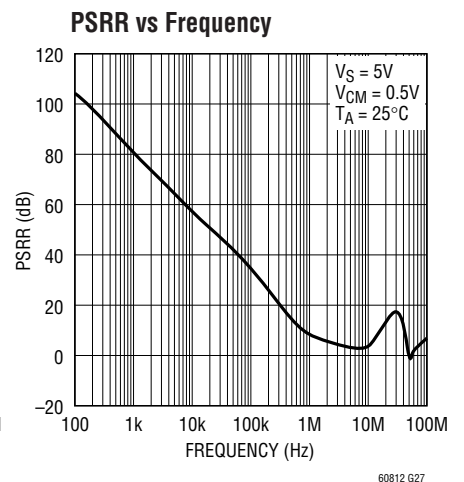
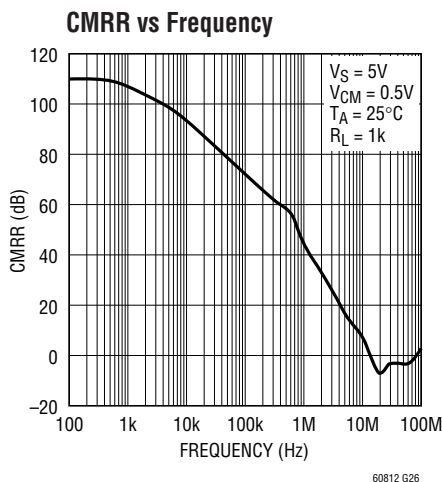
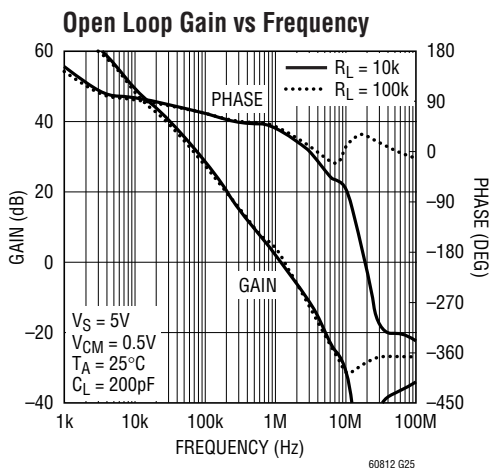
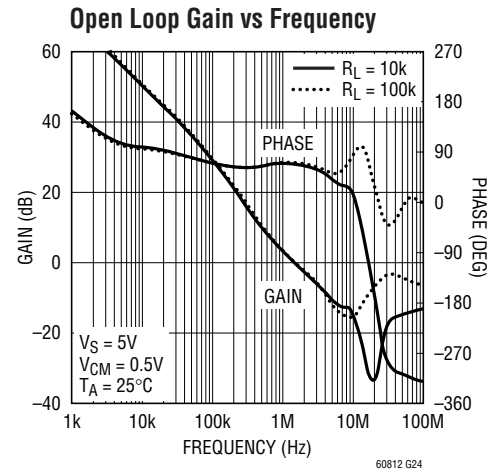
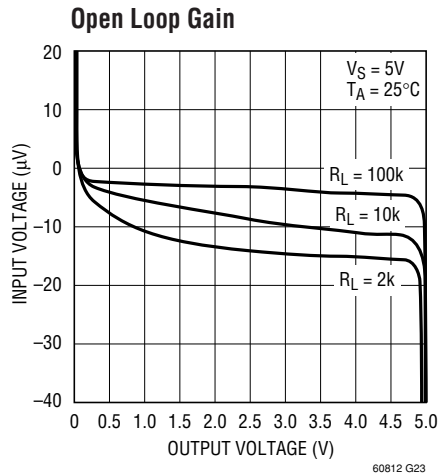
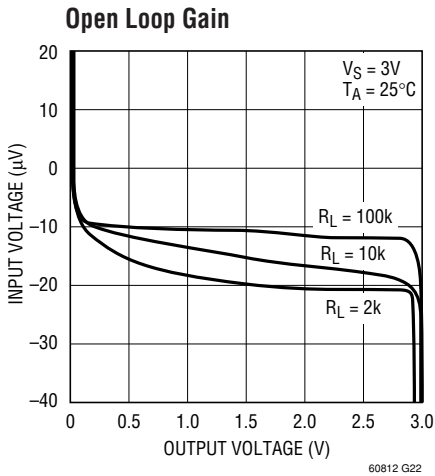
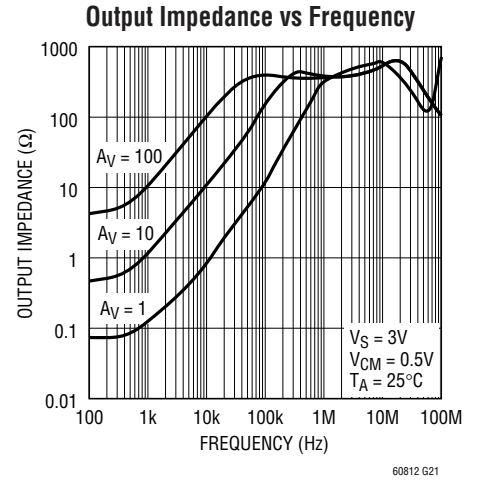
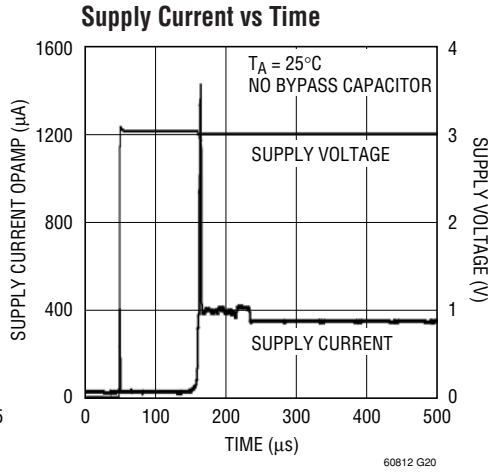
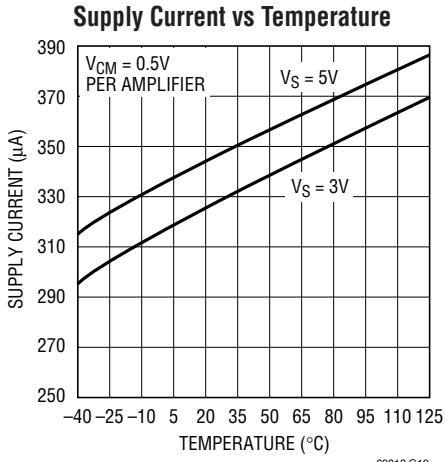

## TYPICAL PERFORMANCE CHARACTERISTICS

Channel Separation vs Frequency

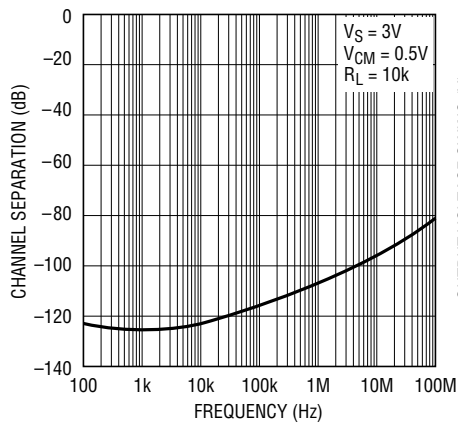

Output Voltage Swing vs Load Current

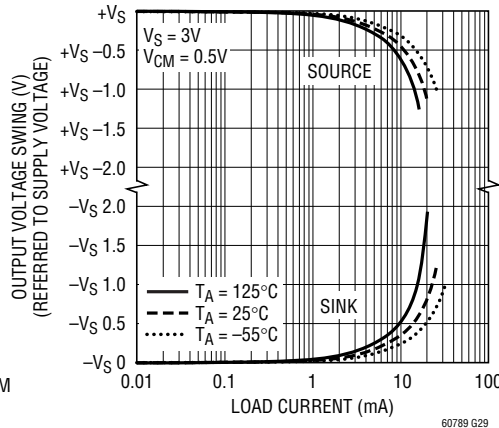

Distortion vs Frequency

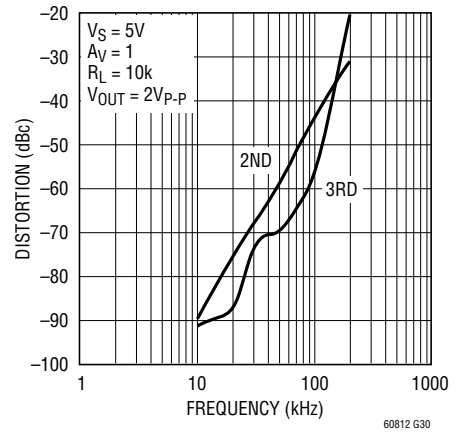

## PIN FUNCTIONS

**OUT:** Amplifier Output

**-IN:** Inverting Input

**+IN:** Noninverting Input

**V<sup>+</sup>:** Positive Supply

**V<sup>-</sup>:** Negative Supply

**SHDN\_A:** Shutdown Pin of Amplifier A, active low and only valid for LTC6081DD. An internal current source pulls the pin to V<sup>+</sup> when floating.

**SHDN\_B:** Shutdown Pin of Amplifier B, active low and only valid for LTC6081DD. An internal current source pulls the pin to V<sup>+</sup> when floating.

**NC:** Not internally connected.

**Exposed Pad:** Connected to V<sup>-</sup>.

## APPLICATIONS INFORMATION

### Preserving Input Precision

Preserving input accuracy of the LTC6081/LTC6082 requires that the application circuit and PC board layout do not introduce errors comparable or greater than the  $5\mu\text{V}$  typical offset of the amplifiers. Temperature differentials across the input connections can generate thermocouple voltages of 10's of microvolts so the connections to the input leads should be short, close together and away from heat dissipating components. Air current across the board can also generate temperature differentials.

The extremely low input bias currents ( $0.1\text{pA}$  typical) allow high accuracy to be maintained with high impedance sources and feedback resistors. Leakage currents on the PC board can be higher than the input bias current. For example,  $10\text{G}\Omega$  of leakage between a  $5\text{V}$  supply lead and an input lead will generate  $500\text{pA}$ ! Surround the input leads with a guard ring driven to the same potential as the input common mode voltage to avoid excessive leakage in high impedance applications.

### Capacitive Load

LTC6081/LTC6082 can drive capacitive load up to  $200\text{pF}$  in unity gain. The capacitive load driving capability increases as the amplifier is used in higher gain configurations. A small series resistance between the output and the load further increases the amount of capacitance the amplifier can drive.

### SHDN Pins

Pins 5 and 6 are used for power shutdown on the LTC6081 in the DD package. If they are floating, internal current sources pull Pins 5 and 6 to  $V^+$  and the amplifiers operate normally. In shutdown, the amplifier output is high impedance, and each amplifier draws less than  $2\mu\text{A}$  current.

### Rail-to-Rail Input

The input stage of LTC6081/LTC6082 combines both PMOS and NMOS differential pairs, extending its input common mode voltage range to both positive and negative supply voltages. At high input common mode range, the NMOS pair is on. At low common mode range, the PMOS pair is on. The transition happens when the common voltage is between  $1.3\text{V}$  and  $0.9\text{V}$  below the positive supply. LTC6081 has better low frequency noise performance with PMOS input on due to its lower flicker noise (see Voltage Noise vs Frequency and  $0.1\text{Hz}$  to  $10\text{Hz}$  Input Voltage Noise in Typical Performance Characteristics).

### Thermal Hysteresis

Figure 1 shows the input offset voltage hysteresis of the LTC6081IMS8 for 3 thermal cycles from  $-45^\circ\text{C}$  to  $90^\circ\text{C}$ . The typical offset shift is  $\pm 4\mu\text{V}$ . The data was taken with the ICs in stress free sockets. Mounting to PC boards may cause additional hysteresis due to mechanical stress. The LTC6081 will meet offset voltage specifications in the electrical characteristics table even after  $15\mu\text{V}$  of additional error from thermal hysteresis.

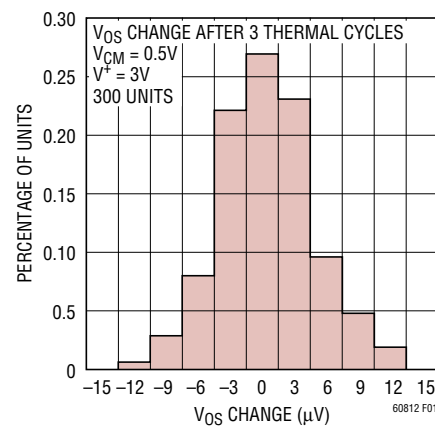

Figure 1.  $V_{OS}$  Thermal Hysteresis of LTC6081IMS8

## APPLICATIONS INFORMATION

### PC Board Layout

Mechanical stress on a PC board and soldering-induced stress can cause the  $V_{OS}$  and  $V_{OS}$  drift to shift. The DD and DHC packages are more sensitive to stress. A simple way to reduce the stress-related shifts is to mount the IC near the short edge of the PC board, or in a corner. The board edge acts as a stress boundary, or a region where the flexure of the board is minimum. The package should always be mounted so that the leads absorb the stress

and not the package. The package is generally aligned with the leads perpendicular to the long side of the PC board (see Figure 2).

The most effective technique to relieve the PC board stress is to cut slots in the board around the op amp. These slots can be cut on three sides of the IC and the leads can exit on the fourth side. Figure 2 shows the layout of a LTC6081DD with slots at three sides.

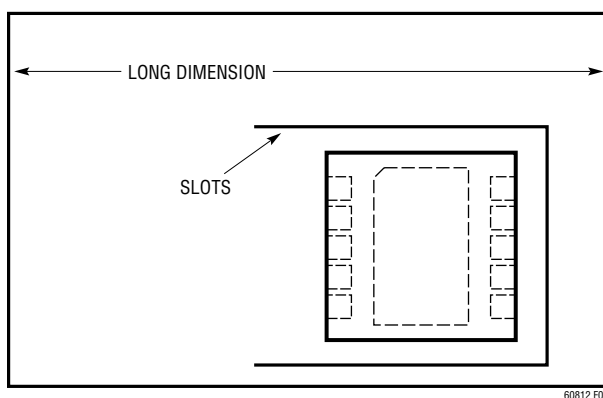
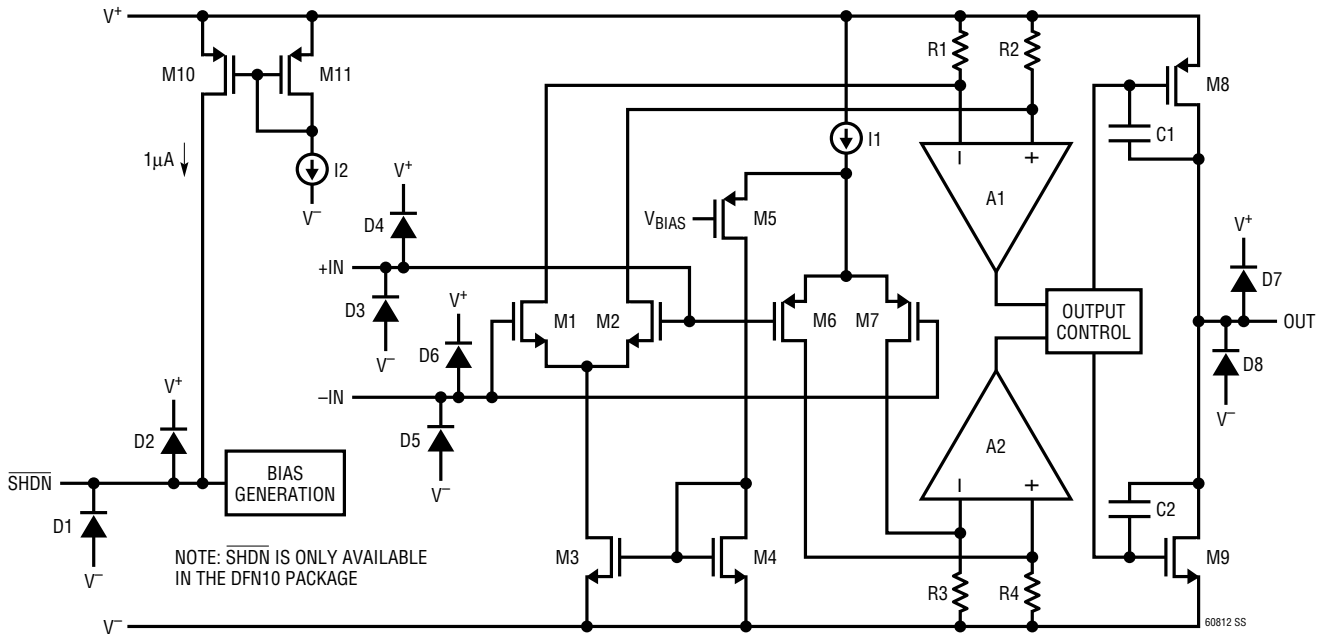

Figure 2. Vertical Orientation of LTC6081DD with Slots

# SIMPLIFIED SCHEMATIC

Simplified Schematic of the Amplifier



## TYPICAL APPLICATIONS

### Low Side Current Sense

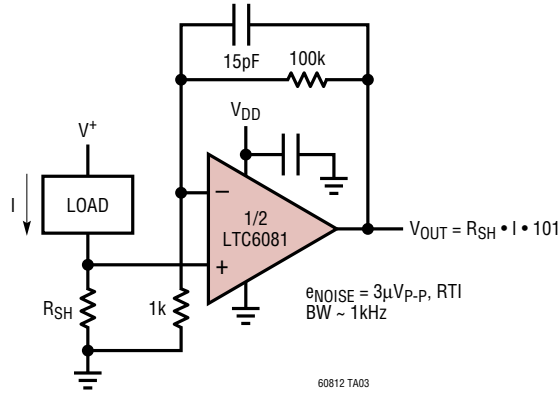

### Two Op-Amp Instrumentation Amplifier

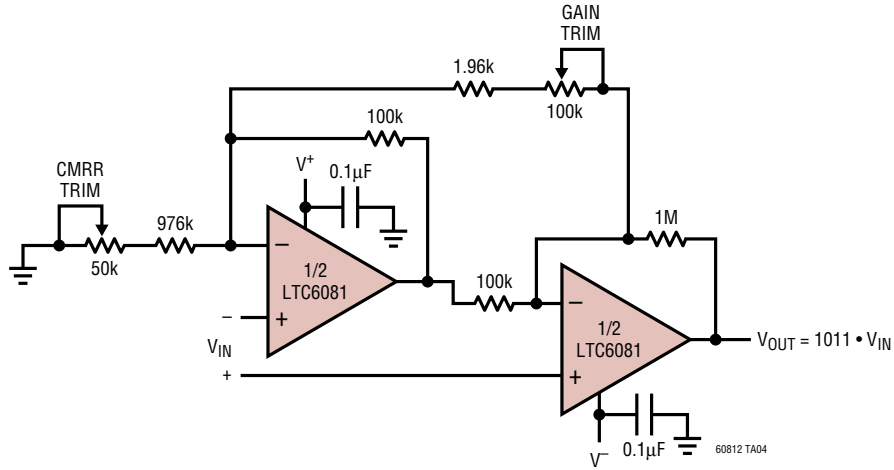

TYPICAL APPLICATIONS

Thermocouple Amplifier

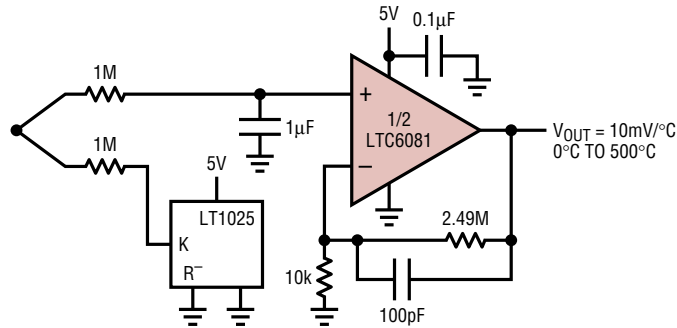

SENSOR: OMEGA 5TC-TT-K-30-36 K-TYPE THERMOCOUPLE  
 1M RESISTORS PROTECT CIRCUIT TO ±350V WITH NO PHASE REVERSAL OF AMPLIFIER OUTPUT  
 1pA MAX I<sub>BIAS</sub> TRANSLATES TO 0.05°C ERROR  
 20µV V<sub>OS</sub> → 0.5°C OFFSET

60812 TA05

Precision Nanoamp Bidirectional Current Source

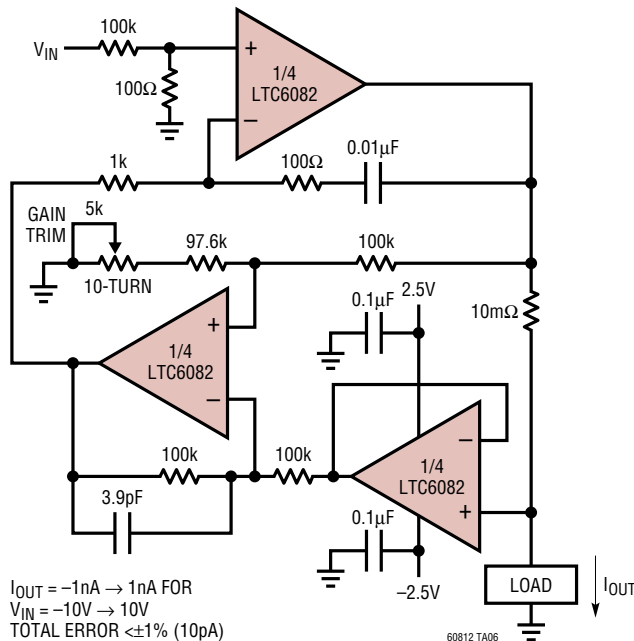

I<sub>OUT</sub> = -1nA → 1nA FOR  
 V<sub>IN</sub> = -10V → 10V  
 TOTAL ERROR <±1% (10pA)

60812 TA06

PACKAGE DESCRIPTION

**DD Package**  
**10-Lead Plastic DFN (3mm × 3mm)**  
 (Reference LTC DWG # 05-08-1699)

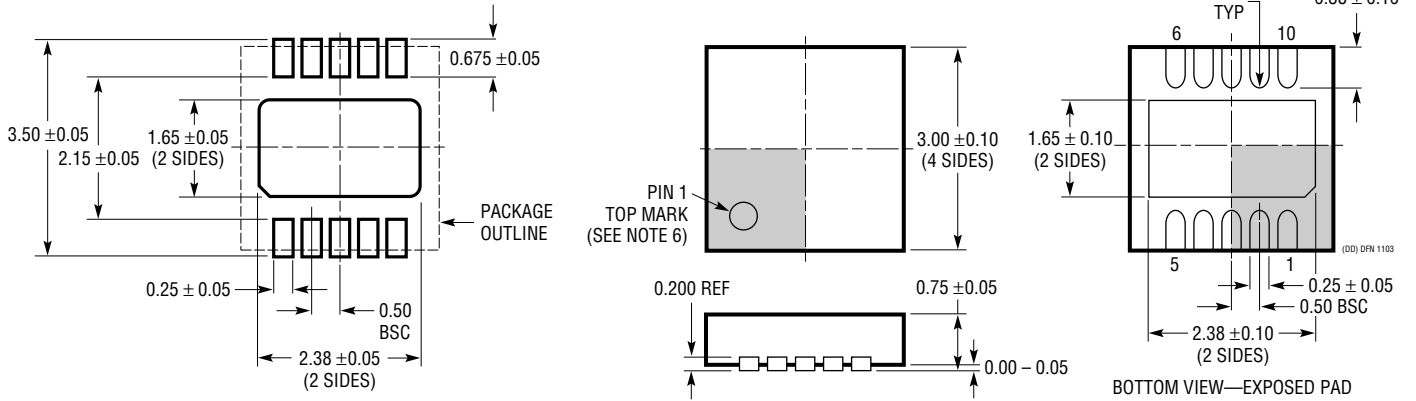

**RECOMMENDED SOLDER PAD PITCH AND DIMENSIONS**

NOTE:

1. DRAWING TO BE MADE A JEDEC PACKAGE OUTLINE M0-229 VARIATION OF (WEED-2).  
CHECK THE LTC WEBSITE DATA SHEET FOR CURRENT STATUS OF VARIATION ASSIGNMENT
2. DRAWING NOT TO SCALE
3. ALL DIMENSIONS ARE IN MILLIMETERS
4. DIMENSIONS OF EXPOSED PAD ON BOTTOM OF PACKAGE DO NOT INCLUDE MOLD FLASH. MOLD FLASH, IF PRESENT, SHALL NOT EXCEED 0.15mm ON ANY SIDE
5. EXPOSED PAD SHALL BE SOLDER PLATED
6. SHADED AREA IS ONLY A REFERENCE FOR PIN 1 LOCATION ON THE TOP AND BOTTOM OF PACKAGE



## PACKAGE DESCRIPTION

**DHC Package**  
**16-Lead Plastic DFN (5mm × 3mm)**  
 (Reference LTC DWG # 05-08-1706)

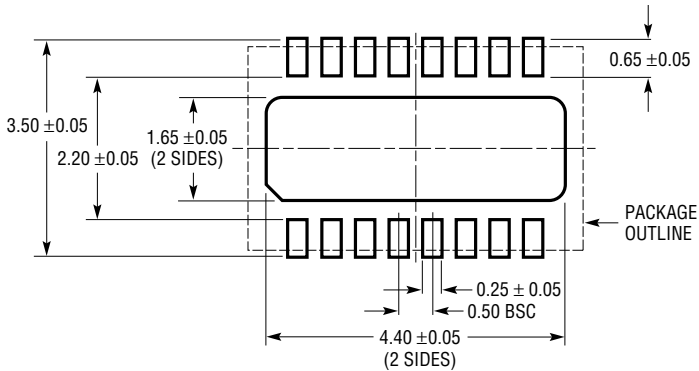

**RECOMMENDED SOLDER PAD PITCH AND DIMENSIONS**

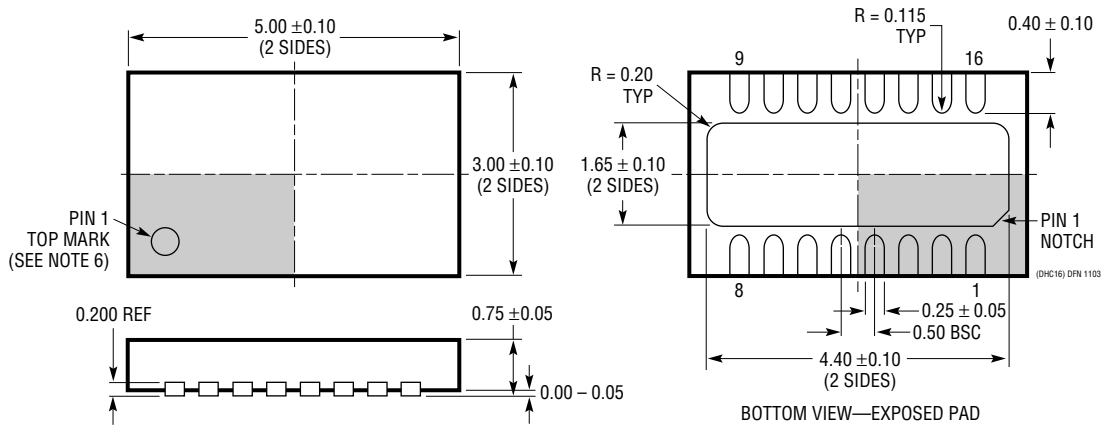

- NOTE:
1. DRAWING PROPOSED TO BE MADE VARIATION OF VERSION (WJED-1) IN JEDEC PACKAGE OUTLINE MO-229
  2. DRAWING NOT TO SCALE
  3. ALL DIMENSIONS ARE IN MILLIMETERS
  4. DIMENSIONS OF EXPOSED PAD ON BOTTOM OF PACKAGE DO NOT INCLUDE MOLD FLASH. MOLD FLASH, IF PRESENT, SHALL NOT EXCEED 0.15mm ON ANY SIDE
  5. EXPOSED PAD SHALL BE SOLDER PLATED
  6. SHADED AREA IS ONLY A REFERENCE FOR PIN 1 LOCATION ON THE TOP AND BOTTOM OF PACKAGE

## PACKAGE DESCRIPTION

### GN Package 16-Lead Plastic SSOP (Narrow .150 Inch) (Reference LTC DWG # 05-08-1641)

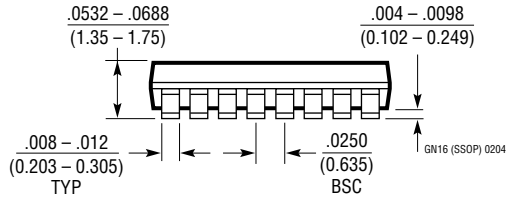
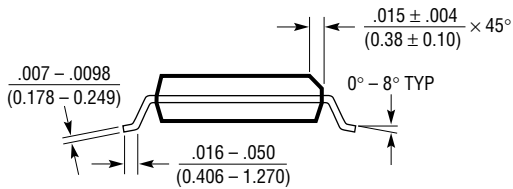
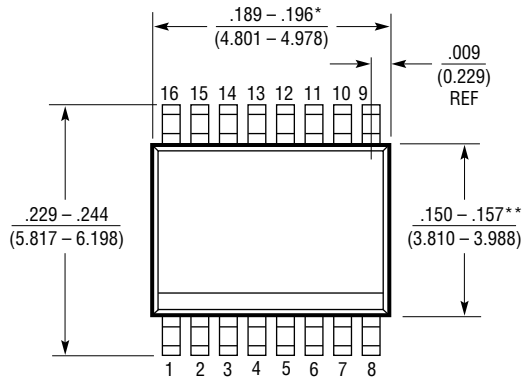
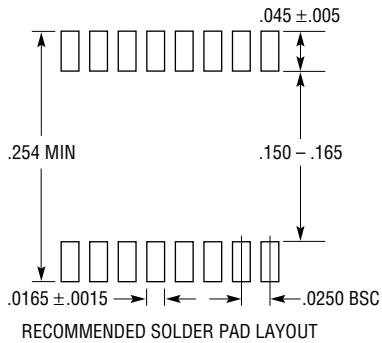

NOTE:

1. CONTROLLING DIMENSION: INCHES
2. DIMENSIONS ARE IN  $\frac{\text{INCHES}}{\text{MILLIMETERS}}$
3. DRAWING NOT TO SCALE

\*DIMENSION DOES NOT INCLUDE MOLD FLASH. MOLD FLASH SHALL NOT EXCEED 0.006" (0.152mm) PER SIDE

\*\*DIMENSION DOES NOT INCLUDE INTERLEAD FLASH. INTERLEAD FLASH SHALL NOT EXCEED 0.010" (0.254mm) PER SIDE

# PACKAGE DESCRIPTION

**MS8 Package**  
**8-Lead Plastic MSOP**  
 (Reference LTC DWG # 05-08-1660)

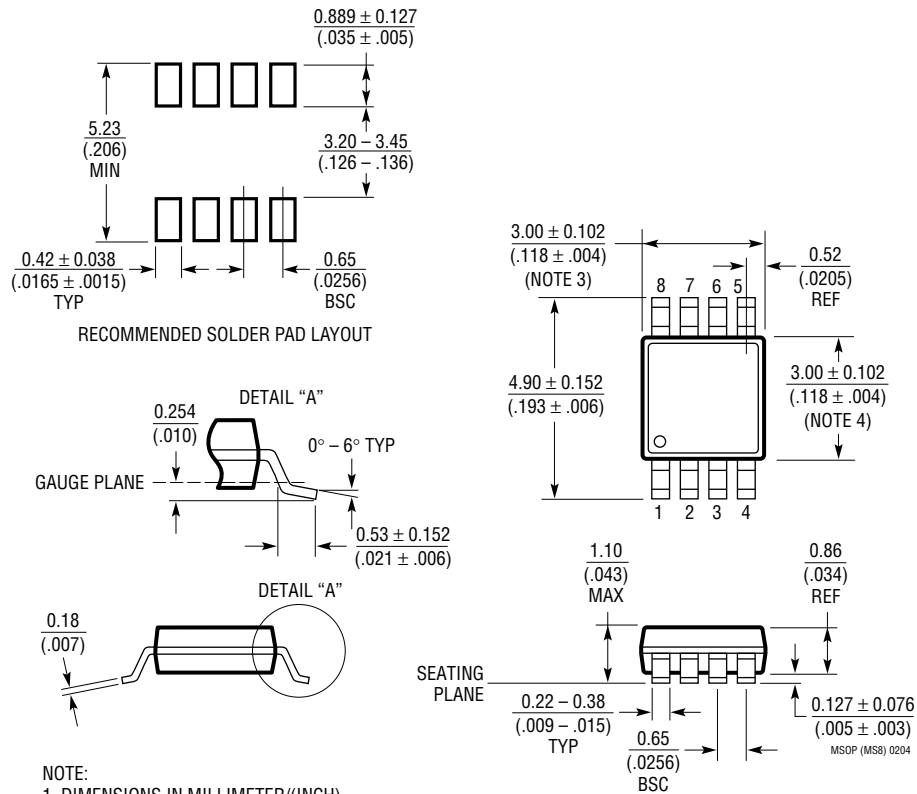

**NOTE:**

1. DIMENSIONS IN MILLIMETER/(INCH)
2. DRAWING NOT TO SCALE
3. DIMENSION DOES NOT INCLUDE MOLD FLASH, PROTRUSIONS OR GATE BURRS.  
 MOLD FLASH, PROTRUSIONS OR GATE BURRS SHALL NOT EXCEED 0.152mm (.006") PER SIDE
4. DIMENSION DOES NOT INCLUDE INTERLEAD FLASH OR PROTRUSIONS.  
 INTERLEAD FLASH OR PROTRUSIONS SHALL NOT EXCEED 0.152mm (.006") PER SIDE
5. LEAD COPLANARITY (BOTTOM OF LEADS AFTER FORMING) SHALL BE 0.102mm (.004") MAX

# LTC6081/LTC6082

## TYPICAL APPLICATION

Single Supply Strain Gauge Amplifier

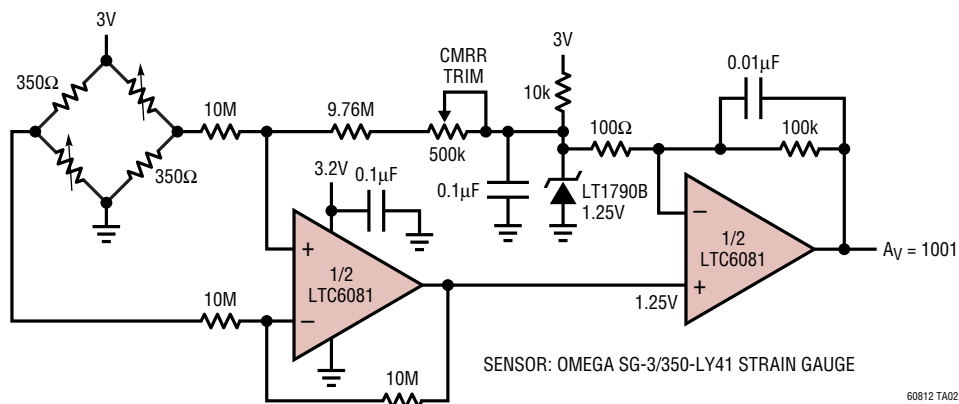

## RELATED PARTS

PART NUMBER	DESCRIPTION	COMMENTS
LT1678/LT1679	Dual/Quad Precision Op Amps	Low Noise, 2.7V to 36V Operation
LTC2050	Zero-Drift Op Amp	2.7V Operation, SOT-23 Package
LTC2051/LTC2052	Dual/Quad Zero-Drift Op Amps	MS8/GN16 Packages
LTC2054/LTC2055	Single/Dual Zero-Drift Op Amp	Micropower, SOT-23 and DFN Packages
LTC6078/LTC6079	Dual/Quad Low Noise Precision CMOS Op Amps	Micropower 0.7μV/°C V <sub>OS</sub> Drift
LTC6241/LTC6242	Dual/Quad Low Noise CMOS Op Amps	18MHz Bandwidth, 10V/μs Slew Rate
LTC6244	Dual 50MHz CMOS Op Amp	Low Noise, Rail-to-Rail Out, MS8 and DFN Packages