

NEW Product

DC/DC CONVERTERS POLA Non-isolated

1

- 10 A output current
- 12 V input voltage
- Wide-output voltage adjust
 - 1.2 Vdc to 5.5 Vdc for suffix 'W' and 0.8 Vdc to 1.8 Vdc for suffix 'L'
- Auto-track™ sequencing*
- Margin up/down controls
- Efficiencies up to 94%
- Output ON/OFF inhibit
- Output voltage sense
- Point-of-Load-Alliance (POLA) compatible
- Available RoHS compliant

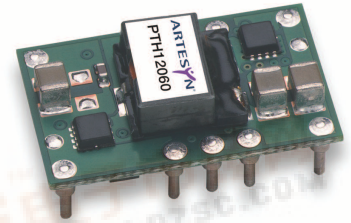

The PTH12060 is a next generation series of non-isolated dc-dc converters offering some of the most advanced POL features available in the industry. The primary new feature provides for sequencing between multiple modules, a function, which is becoming a necessity for powering advanced silicon including DSP's, FPGA's and ASIC's requiring controlled power-up and power-down. Other industry leading features include margin up/down controls and efficiencies up to 94%. The PTH12060 has an input voltage of 10.8 Vdc to 13.2 Vdc and offers a wide output voltage range adjustable with external trim resistor, allowing for maximum design flexibility and a pathway for future upgrades.



All specifications are typical at nominal input, full load at 25 °C unless otherwise stated
 $C_{in} = 560 \mu F$, $C_{out} = 0 \mu F$

SPECIFICATIONS

OUTPUT SPECIFICATIONS

Voltage adjustability (See Note 4)	Suffix 'W' Suffix 'L'	1.2-5.5 Vdc 0.8-1.8 Vdc
Setpoint accuracy		±2.0% V_o
Line regulation		±10 mV typ.
Load regulation		±12 mV typ.
Total regulation		±3.0% V_o
Minimum load		0 A
Ripple and noise (See Note 8)	Suffix 'W' $V_o > 2.5 V$ Suffix 'L' $V_o > 1.0 V$	25 mV pk-pk 1% V_o 20 mV pk-pk 30 mV pk-pk
Temperature co-efficient	-40 °C to +85 °C	±0.5% V_o
Transient response (See Note 5)		70 μs recovery time Overshoot/undershoot 100 mV
Margin adjustment		±5.0% V_o

INPUT SPECIFICATIONS

Input voltage range (See Note 3)		10.8-13.2 Vdc
Input current	No load	10 mA typ.
Remote ON/OFF (See Note 1)		Positive logic
Start-up time		1 V/ms
Undervoltage lockout		9.0-9.5 V typ.
Track input voltage	Pin 8 (See Note 6)	±0.3 V_{in}

EMC CHARACTERISTICS

Electrostatic discharge	EN61000-4-2, IEC801-2
Conducted immunity	EN61000-4-6
Radiated immunity	EN61000-4-3

GENERAL SPECIFICATIONS

Efficiency	See Tables on page 2	
Insulation voltage	Non-isolated	
Switching frequency	Suffix 'W' Suffix 'L'	350 kHz typ. 250 kHz typ.
Approvals and standards	EN60950 UL/cUL60950	
Material flammability	UL94V-0	
Dimensions (L x W x H)	25.27 x 15.75 x 9.00 mm 0.995 x 0.620 x 0.354 in	
Weight	5 g (0.18 oz)	
MTBF	Telcordia SR-332	7,092,000 hours

ENVIRONMENTAL SPECIFICATIONS

Thermal performance (See Note 2)	Operating ambient, temperature Non-operating	-40 °C to +85 °C -40 °C to +125 °C
MSL ('Z' suffix only)	JEDEC J-STD-020C	Level 3

PROTECTION

Short-circuit	Auto reset	20 A typ.
---------------	------------	-----------

*Auto-track™ is a trade mark of Texas Instruments

OUTPUT POWER (MAX.)	INPUT VOLTAGE	OUTPUT VOLTAGE	OUTPUT CURRENT (MIN.)	OUTPUT CURRENT (MAX.)	EFFICIENCY (MAX.)	REGULATION		MODEL NUMBER
						LINE	LOAD	
55 W	10.8-13.2 Vdc	0.8-1.8 Vdc	0 A	10 A	88%	±10 mV	±12 mV	PTH12060L
55 W	10.8-13.2 Vdc	1.2-5.5 Vdc	0 A	10 A	94%	±10 mV	±12 mV	PTH12060W

Part Number System with Options

PTH12060WAST

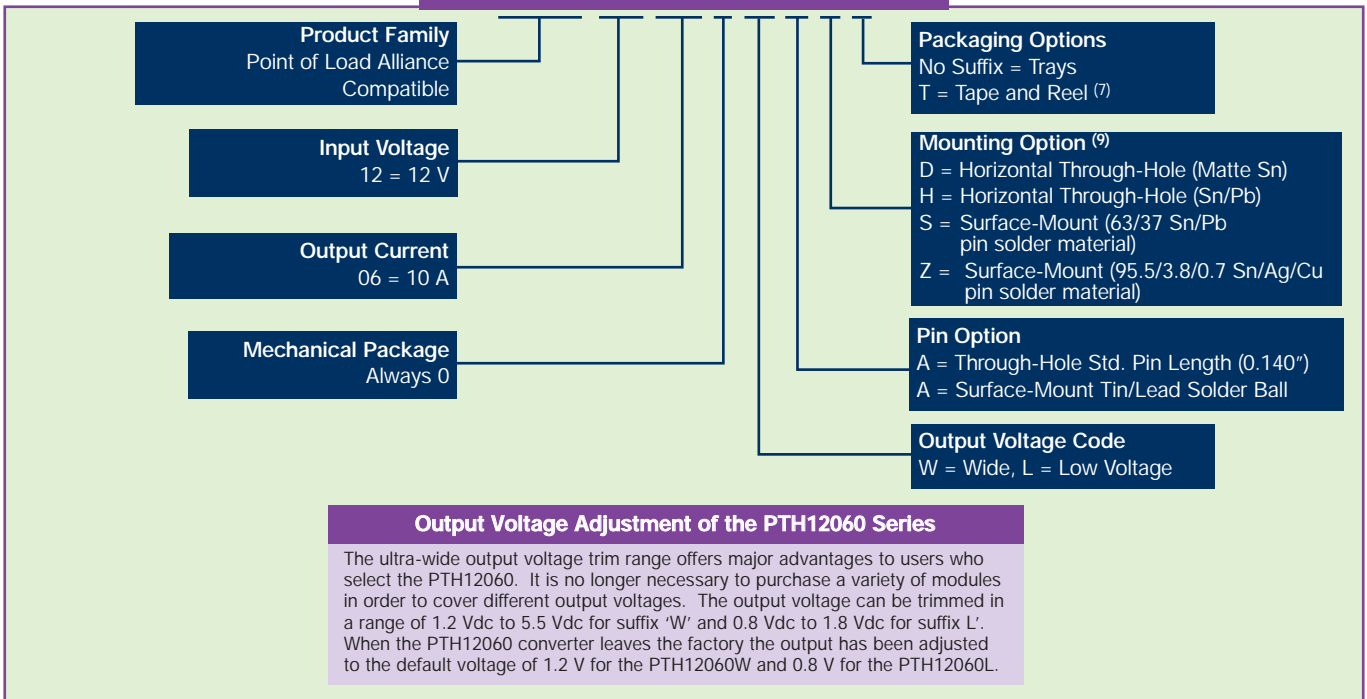

Output Voltage Adjustment of the PTH12060 Series

The ultra-wide output voltage trim range offers major advantages to users who select the PTH12060. It is no longer necessary to purchase a variety of modules in order to cover different output voltages. The output voltage can be trimmed in a range of 1.2 Vdc to 5.5 Vdc for suffix 'W' and 0.8 Vdc to 1.8 Vdc for suffix 'L'. When the PTH12060 converter leaves the factory the output has been adjusted to the default voltage of 1.2 V for the PTH12060W and 0.8 V for the PTH12060L.

Notes

- Remote ON/OFF. Active High
ON: Pin 3 open; or $V > V_{in} - 0.5 V$
OFF: Pin 3 GND; or $V < 0.8 V$ (min - 0.2 V).
- See Figures 1, 2 and 3 for safe operating curves of PTH12060W and Figures 6, 7 and 8 for safe operating curves of PTH12060L.
- A 560 μF electrolytic input capacitor is required for proper operation. The capacitor must be rated for a minimum of 800 mA rms of ripple current.
- An external output capacitor is not required for basic operation. Adding 330 μF of distributed capacitance at the load will improve the transient response.
- 1 A/ μs load step, 50 to 100% I_{omax} ; $C_{out} = 330 \mu F$.
- If utilized V_{out} will track applied voltage by $\pm 0.3 V$ (up to V_o set point).
- Tape and reel packaging only available on the surface-mount versions.
- The pk-pk output ripple voltage is measured with an external 10 μF ceramic capacitor. See Figures 5 and 8 for Standard application schematic.
- To order Pb-free (RoHS compatible) surface-mount parts replace the mounting option 'S' with 'Z', e.g. PTH12060WAZ. To order Pb-free (RoHS compatible) through-hole parts replace the mounting option 'H' with 'D', e.g. PTH12060WAD.

EFFICIENCY TABLE - PTH12060W ($I_o = 8 A$)

OUTPUT VOLTAGE	EFFICIENCY
$V_o = 5.0 V$	94%
$V_o = 3.3 V$	92%
$V_o = 2.5 V$	90%
$V_o = 2.0 V$	88%
$V_o = 1.8 V$	87%
$V_o = 1.5 V$	85%
$V_o = 1.2 V$	83%

EFFICIENCY TABLE - PTH12060L ($I_o = 8 A$)

OUTPUT VOLTAGE	EFFICIENCY
$V_o = 1.8 V$	88%
$V_o = 1.5 V$	87%
$V_o = 1.2 V$	84%
$V_o = 1.0 V$	82%

PTH12060W Characteristic Data

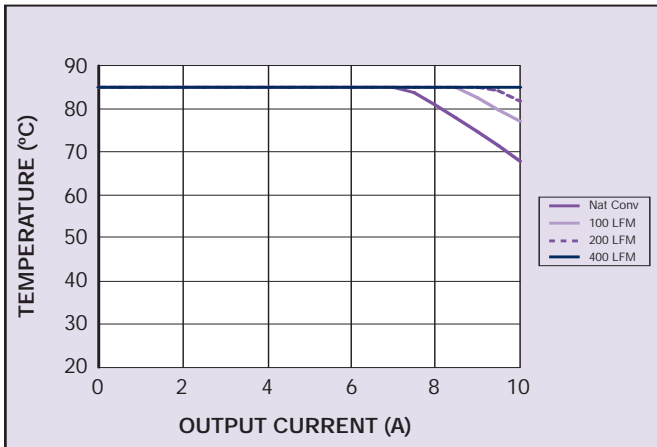

Figure 1 - Safe Operating Area for PTH12060W
Vin = 12 V, Output Voltage = 5 V (See Note A)

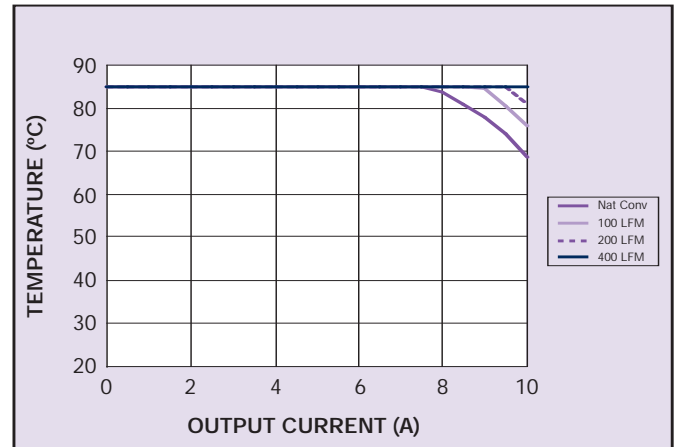

Figure 2 - Safe Operating Area for PTH12060W
Vin = 12 V, Output Voltage = 3.3 V (See Note A)

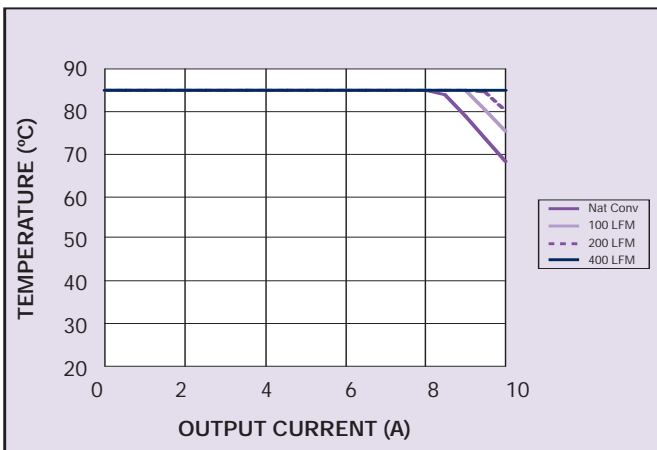

Figure 3 - Safe Operating Area for PTH12060W
Vin = 12 V, Output Voltage = 1.8 V (See Note A)

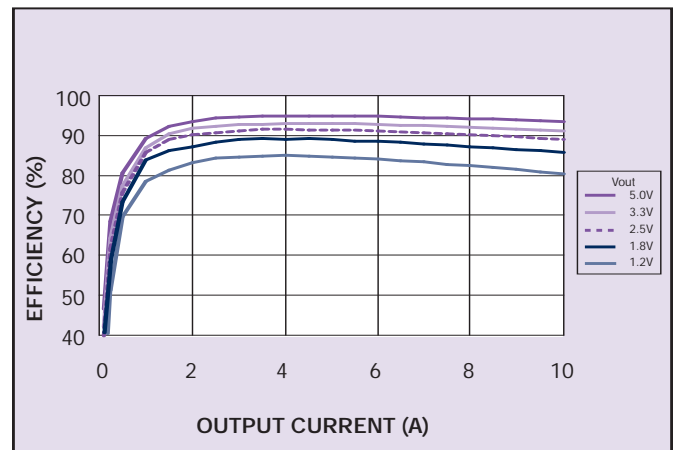

Figure 4 - Efficiency vs Load Current for PTH12060W
Vin = 12 V (See Note B)

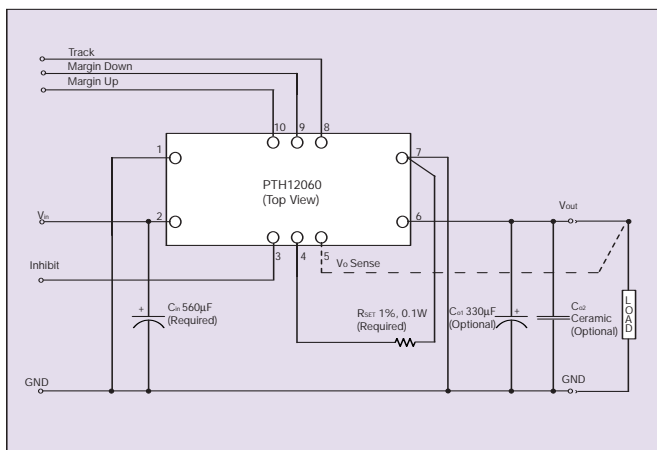

Figure 5 - Standard Application - All Models

Notes

- A SOA curves represent the conditions at which internal components are within the Artesyn derating guidelines.
- B Characteristic data has been developed from actual products tested at 25 °C. This data is considered typical data for the converter.

PTH12060L Characteristic Data

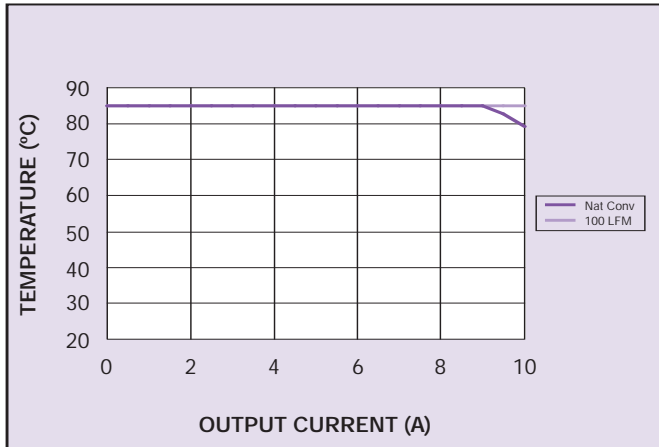

Figure 6 - Safe Operating Area for PTH12060L
Vin = 12 V, Output Voltage 1.8 V (See Note A)

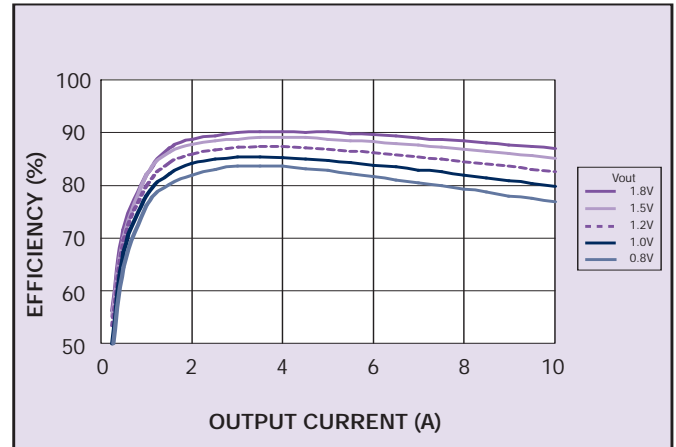

Figure 7 - Efficiency vs Load Current for PTH12060L
Vin = 12 V (See Note B)

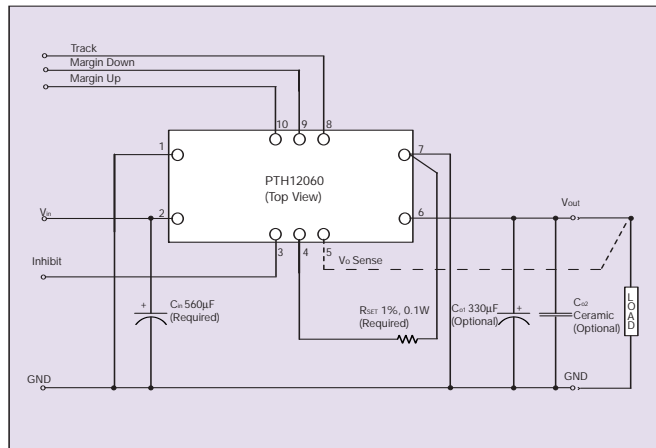

Figure 8 - Standard Application - All Models

Notes

- A SOA curves represent the conditions at which internal components are within the Artesyn derating guidelines.
- B Characteristic data has been developed from actual products tested at 25 °C. This data is considered typical data for the converter.

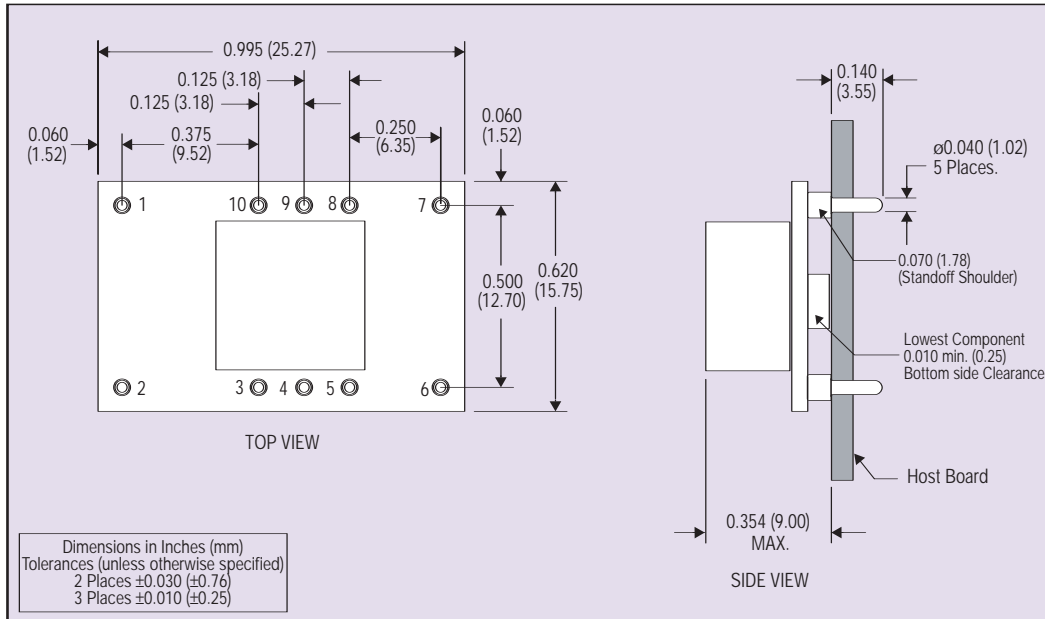

Figure 9 - Plated Through-Hole Mechanical Drawing

PIN CONNECTIONS	
PIN NO.	FUNCTION
1	Ground
2	Vin
3	Inhibit*
4	Vo adjust
5	Vo sense
6	Vout
7	Ground
8	Track
9	Margin down*
10	Margin up*

*Denotes negative logic:
Open = Normal operation
Ground = Function active

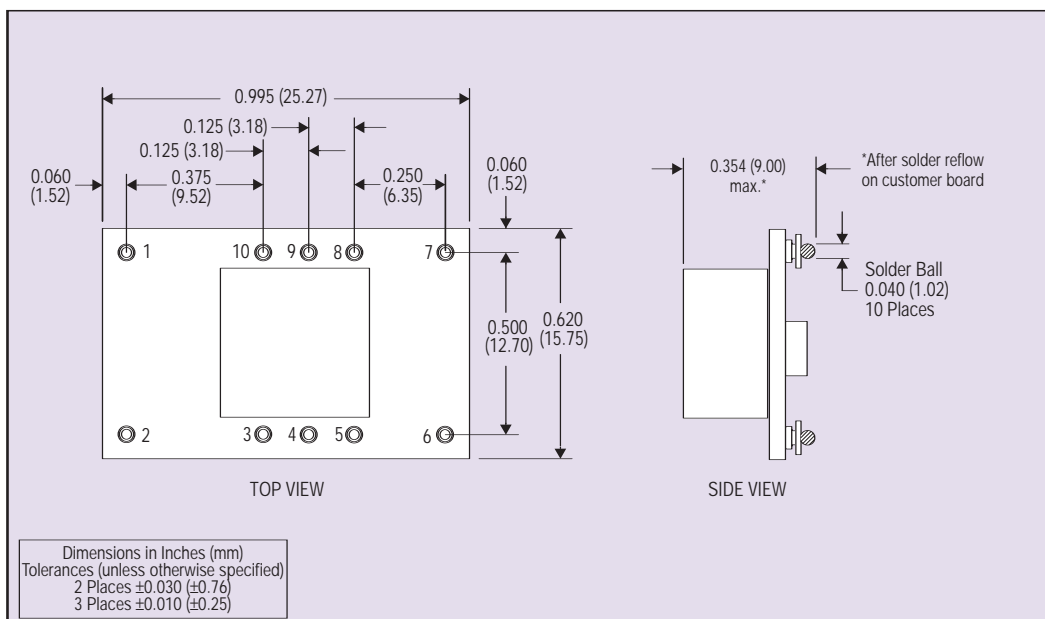

Figure 10 - Surface-Mount Mechanical Drawing