

Description

YB1880 is a complete constant-current & constant voltage linear charger for single cell lithium-ion batteries. Its SOT-23 package and low external component count make YB1880 ideally suited for portable applications. Furthermore, the YB1880 is specifically designed to work within USB power specification. At the same time, YB1880 can also be used in the standalone lithium-ion battery charger.

No external sense resistor is needed, and no blocking diode is required due to the internal MOSFET architecture. Thermal feedback regulates the charger current to limit the die temperature during high power operation or high ambient temperature. The charge voltage is fixed at 4.2V, and the charge current can be programmed externally with a single resistor. The YB1880 automatically terminates the charge cycle when the charge current drops to 1/10th the programmed value after the final float voltage is reached.

When the input supply (wall adapter or USB supply) is removed, the YB1880 automatically enters a low current stage, dropping the battery drain current to less than 2µA. The YB1880 can be put into shutdown mode, reducing the supply current to 20µA.

Other features include charge current monitor, under-voltage lockout, automatic recharge and a status pin to indicate charge termination and the presence of an input voltage.

Typical Application Circuit

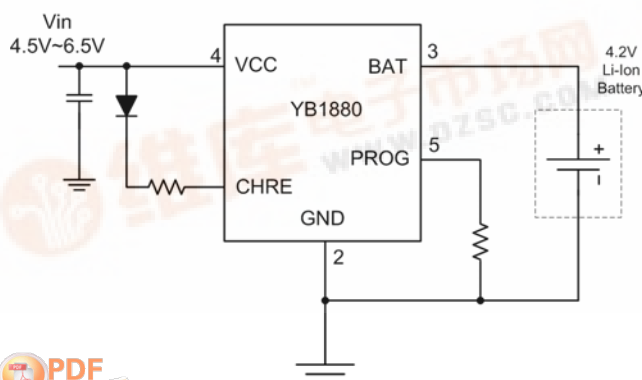

Features

- Programmable Charge Current Up to 800mA
- No MOSFET, Sense Resistor or Blocking Diode Required
- Constant-Current/Constant-Voltage Operation with Thermal Protection to Maximize Charge Rate without Risk of Overheating
- Charges Single Cell Li-ion Batteries Directly from USB Port
- Preset 4.2V Charge Voltage with +-1% Accuracy
- 20µA Supply Current in Shutdown
- 2.9V Trickle Charge Threshold
- Available Without Trickle Charge
- Soft-Start Limits Inrush Current
- Available in 5-Lead SOT-23 Package
- Pb-free Package

Application

- Cellular and Smart Phones
- Microprocessors and DSP Core Supplies
- Wireless and DSL Modems
- PDA
- MP3 Player
- Digital Still and Video Cameras
- Portable Instruments

Pin Configuration

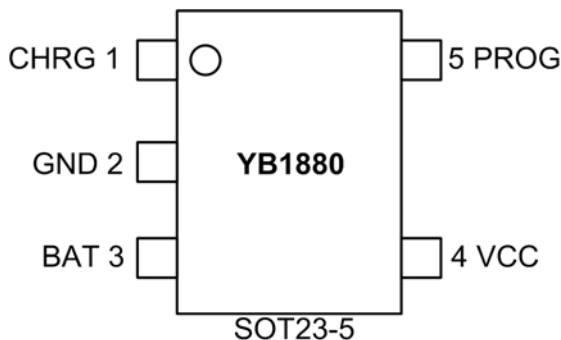

Figure 2: Pin Configuration

Pin Description

Table 1

Pin Number	Pin Name	Description
1	CHRG	Open-Drain Charge Status Output. When the battery is charging, the CHRG pin is pulled low by an internal N-channel MOSFET. When the charge cycle is completed, a weak pull-down of approximately 20mA is connected to the CHRG pin, indicating an “AC present” condition. When the YB1880 detects an under voltage lockout condition, CHRG is forced high impedance.
2	GND	Ground
3	BAT	Charge Current Output. Provides charge current to the battery and regulates the final float voltage to 4.2V. An internal precision resistor divider from this pin sets the float voltage which is disconnected in shutdown mode.
4	VCC	Positive Input Supply Voltage. Provides power to the charger. VCC can range from 4.25V to 6.5V and should be bypassed with at least a 1mF capacitor. When VCC drops to within 30mV of the BAT pin voltage, the YB1880 enters shutdown mode, dropping IBAT to less than 2mA.
5	PROG	Charge Current Program, Charge Current Monitor and Shutdown Pin. The charge current is programmed by connecting a 1% resistor, RPROG, to ground. When charging in constant-current mode, this pin serves to 1V. In all modes, the voltage on this pin can be used to measure the charge current using the following formula: $IBAT = (VPROG/RPROG) \cdot 1000$ <p>The PROG pin can also be used to shut down the charger. Disconnecting the program resistor from ground allows a 3mA current to pull the PROG pin high. When it reaches the 1.21V shutdown threshold voltage, the charger enters shutdown mode, charging stops and the input supply current drops to 25mA. This pin is also clamped to approximately 2.4V. Driving this pin to voltages beyond the clamp voltage will draw currents as high as 1.5mA. Reconnecting RPROG to ground will return the charger to normal operation.</p>

Ordering Information

Order Number	Package Type	Supplied As	Package Marking
YB1880ST25P	SOT23-5	3000 units Tape & Reel	Please contact sales representative

Absolute Maximum Rating ⁽¹⁾

Parameter	Symbol	Value	Units
Input Supply Voltage	V_{CC}	8	V
PROG Voltage	V_{PROG}	$V_{CC}+0.3$	V
BAT Voltage	V_{BAT}	7	V
CHRG Voltage	V_{CHRG}	10	V
BAT Short-Circuit Duration	—	Continuous	—
Thermal Resistance, Junction-to-Ambient	Θ_{JA}	250 (SOT-23-5)	$^{\circ}C/W$
BAT Pin Current	I_{BAT}	800	mA
PROG Pin Current	I_{PROG}	800	μA
Maximum Junction Temperature	T_J	125	$^{\circ}C$
Storage Temperature	T_S	-65 to +125	$^{\circ}C$
Lead Temperature (Soldering, 10 sec)	—	300	$^{\circ}C$

Recommended Operating Conditions ⁽²⁾

Parameter	Symbol	Value	Units
Supply Input Voltage	V_{IN}	-0.3 to +8	V
Junction Temperature	T_J	-40 to +85	$^{\circ}C$

Electrical Characteristics

$V_{IN} = 5V$; $T_J = 25^{\circ}C$; unless otherwise specified.

Symbol	Parameter	Conditions	Min	Typ	Max	Unit
V_{CC}	Input Supply Voltage		4.25	—	6	V
I_{CC}	Input Supply Current	Charge Mode ⁽³⁾ , $R_{PROG} = 10k$	—	110	500	μA
		Standby Mode (Charge Terminated)	—	115	160	μA
		Shutdown Mode(R_{PROG} Not Connected, $V_{CC} < V_{BAT}$, or $V_{CC} < V_{UV}$)	—	20	40	μA
V_{FLOAT}	Regulated Output (Float) Voltage	$I_{BAT} = 30mA$, $I_{CHRG} = 5mA$	4.158	4.2	4.242	V
I_{BAT}	BAT Pin Current	$R_{PROG} = 10k$, Current Mode	90	110	130	mA
		$R_{PROG} = 2k$, Current Mode	—	500	—	mA
		Standby Mode, $V_{BAT} = 4.2V$	0	+/-1	+/-5	μA
		Shutdown Mode (R_{PROG} Not Connected)	—	+/-0.5	+/-5	μA
		Sleep Mode, $V_{CC} = 0V$	—	+/-1	+/-5	μA
I_{TRIKL}	Trickle Charge Current	$V_{BAT} < V_{TRIKL}$, $R_{PROG} = 10k$	12	18	25	mA
V_{TRIKL}	Trickle Charge Threshold Voltage	$R_{PROG} = 10k$, V_{BAT} Rising	2.8	2.9	3.0	V

Electrical Characteristics (Continued)

$V_{IN} = 5V$; $T_J = 25^{\circ}C$; unless otherwise specified

Symbol	Parameter	Conditions	Min	Typ	Max	Unit
V_{UV}	V_{CC} Undervoltage Lockout Threshold	From V_{CC} Low to High	—	3.4	—	V
V_{UVHYS}	V_{CC} Undervoltage Lockout Hysteresis		—	170	—	mV
V_{MSD}	Manual Shutdown Threshold Voltage	PROG Pin Rising	—	1.25	—	V
		PROG Pin Falling	—	1.2	—	V
V_{ASD}	$V_{CC} - V_{BAT}$ Lockout Threshold Voltage	V_{CC} from Low to High	—	100	—	mV
		V_{CC} from High to Low	—	30	—	mV
I_{TERM}	C/10 Termination Current Threshold	$R_{PROG} = 10k^{(4)}$	—	0.1	—	mA/mA
		$R_{PROG} = 2k$	—	0.1	—	mA/mA
V_{PROG}	PROG Pin Voltage	$R_{PROG} = 10k$, Current Mode	0.9	1.03	1.1	V
I_{CHRG}	CHRG Pin Weak Pull-Down Current	$V_{CHRG} = 5V$	8	20	40	μA
V_{CHRG}	CHRG Pin Output Low Voltage	$I_{CHRG} = 5mA$	—	0.35	0.8	V
ΔV_{RECHRG}	Recharge Battery Threshold Voltage	$V_{FLOAT} - V_{RECHRG}$	—	100	—	mV
T_{LIM}	Thermal Protection Temperature		—	120	—	$^{\circ}C$
t_{SS}	Soft-Start Time	$I_{BAT} = 0$ to $1000V/R_{PROG}$	—	100	—	μs
$t_{RECHARGE}$	Recharge Comparator Filter Time	V_{BAT} High to Low	—	2	—	ms
t_{TERM}	Termination Comparator Filter Time	I_{BAT} Falling Below $I_{CHG}/10$	—	1000	—	μs
I_{PROG}	PROG Pin Pull-Up Current		—	1	—	μA

Note 1: Exceeding the absolute maximum rating may damage the device.

Note 2: The device is not guaranteed to function outside its operating rating.

Note 3: Supply current includes PROG pin current (approximately $100\mu A$) but does not include any current delivered to the battery through the BAT pin (approximately $100mA$).

Note 4: I_{TERM} is expressed as a fraction of measured full charge current with indicated PROG resistor.

Typical Performance Characteristics

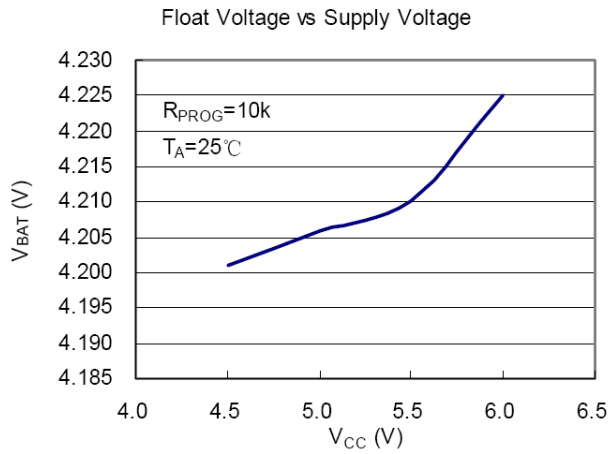

Figure 1.

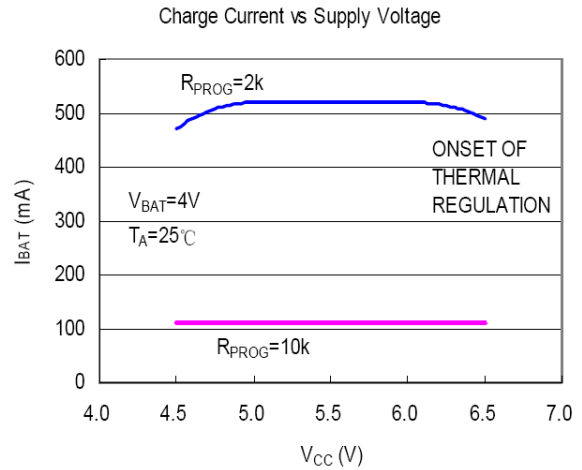

Figure 2.

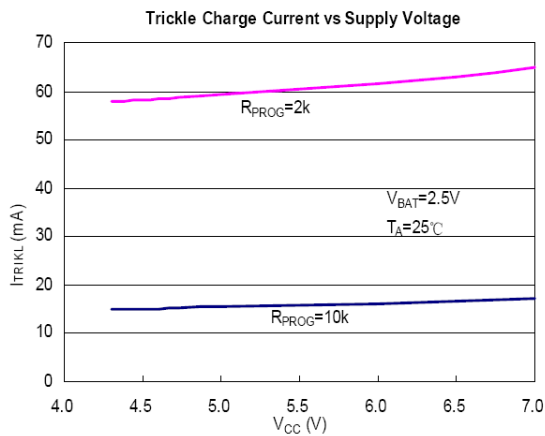

Figure 3.

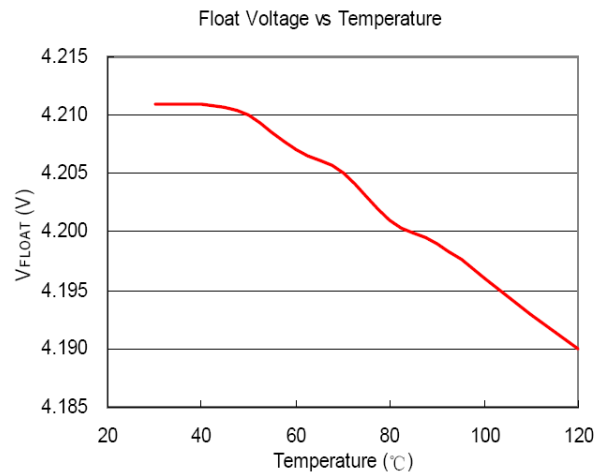
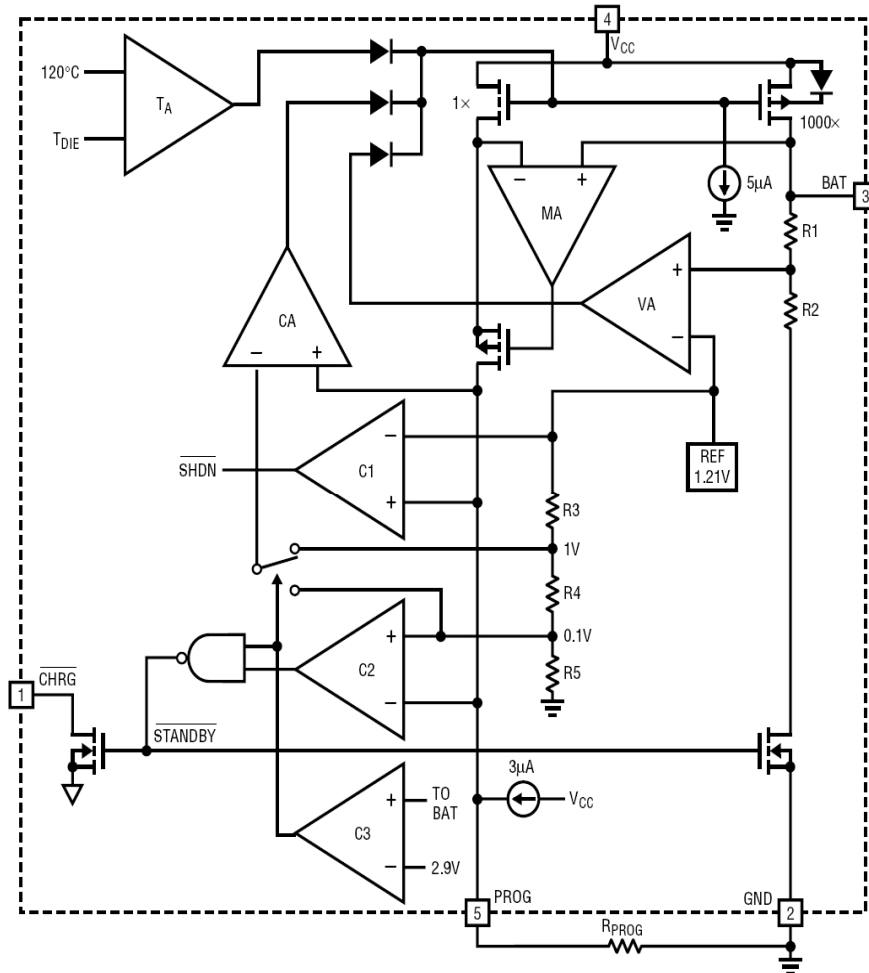

Figure 4.

Function Block



Operation

The YB1880 is a single cell lithium-ion battery charger using a constant-current/constant-voltage algorithm. It can deliver up to 800mA of charge current (using a good thermal PCB layout) with a final float voltage accuracy of $\pm 1\%$. The YB1880 includes an internal P-channel power MOSFET and thermal regulation circuitry. No blocking diode or external current sense resistor is required; thus, the basic charger circuit requires only two external components. Furthermore, the YB1880 is capable of operating from a USB power source.

Normal Charge Cycle

A charge cycle begins when the voltage at the VCC pin rises above the UVLO threshold level and a 1% program resistor is connected from the PROG pin to ground or when a battery is connected to the charger output. If the BAT pin is less than 2.8V, the charger enters trickle charge mode. In this mode, the YB1880 supplies approximately 1/10 the programmed charge current to bring the battery voltage up to a safe level for full current charging. When the BAT pin voltage rises above 2.8V, the charger enters constant-current mode, where the programmed charge current is supplied to the battery. When the BAT pin approaches the final float voltage (4.2V), the YB1880 enters constant-voltage mode and the charge current begins to decrease. When the charge current drops to 1/10 of the programmed value, the charge cycle ends.

Programming Charge Current

The charge current is programmed using a single resistor from the PROG pin to ground. The battery charge current is 1100 times the current out of the PROG pin. The program resistor and the charge current are calculated using the following equations:

$$R_{PROG} = \frac{1100V}{I_{CHG}}, I_{CHG} = \frac{1100V}{R_{PROG}},$$

The charge current out of the BAT pin can be determined at any time by monitoring the PROG pin voltage using the following equation:

$$I_{BAT} = \frac{V_{PROG}}{R_{PROG}} \bullet 1100$$

Charge Termination

A charge cycle is terminated when the charge current falls to 1/10th the programmed value after the final float voltage is reached. This condition is detected by using an internal, filtered comparator to monitor the PROG pin. When the PROG pin voltage falls below 100mV for longer than t_{TERM} (typically 1ms), charging is terminated. The charge current is latched off and the YB1880 enters standby mode, where the input supply current drops to 200mA. (Note: C/10 termination is disabled in trickle charging and thermal limiting modes). When charging, transient loads on the BAT pin can cause the PROG pin to fall below 100mV for short periods of time before the DC charge current has dropped to 1/10th the programmed value. The 1ms filter time (t_{TERM}) on the termination comparator ensures that transient loads of this nature do not result in premature charge cycle termination. Once the average charge current drops below 1/10th the programmed value, the YB1880 terminates the charge cycle and ceases to provide any current through the BAT pin. In this state, all loads on the BAT pin must be supplied by the battery. The YB1880 constantly monitors the BAT pin voltage in standby mode. If this voltage drops below the 4.05V recharge threshold (V_{RECHRG}), another charge cycle begins and current is once again supplied to the battery. To manually restart a charge cycle when in standby mode, the input voltage must be removed and reapplied, or the charger must be shut down and restarted using the PROG pin.

Charge Status Indicator (CHRG)

The charge status output has three different states: strong pull-down (~10mA), weak pull-down (~20 μ A) and high impedance. The strong pull-down state indicates that the YB1880 is in a charge cycle. Once the charge cycle has terminated, the pin state is determined by under voltage lockout conditions. A weak pull-down indicates that V_{CC} meets the UVLO conditions and the YB1880 is ready to charge. High impedance indicates that the YB1880 is in under voltage lockout mode: either V_{CC} is less than 100mV above the BAT pin voltage or insufficient voltage is applied to the V_{CC} pin

Thermal Limiting

An internal thermal feedback loop reduces the programmed charge current if the die temperature attempts to rise above a preset value of approximately 120°C. This feature protects the YB1880 from excessive temperature and allows the user to push the limits of the power handling capability of a given circuit board without risk of damaging the YB1880. The charge current can be set according to typical (not worst-case) ambient temperature with the assurance that the charger will automatically reduce the current in worst-case conditions. Thin SOT power considerations are discussed further in the Applications Information section.

Under voltage Lockout (UVLO)

An internal under voltage lockout circuit monitors the input voltage and keeps the charger in shutdown mode until VCC rises above the under voltage lockout threshold. The UVLO circuit has a built-in hysteresis of 200mV. Furthermore, to protect against reverse current in the power MOSFET, the UVLO circuit keeps the charger in shutdown mode if VCC falls to within 30mV of the battery voltage. If the UVLO comparator is tripped, the charger will not come out of shutdown mode until VCC raises 100mV above the battery voltage.

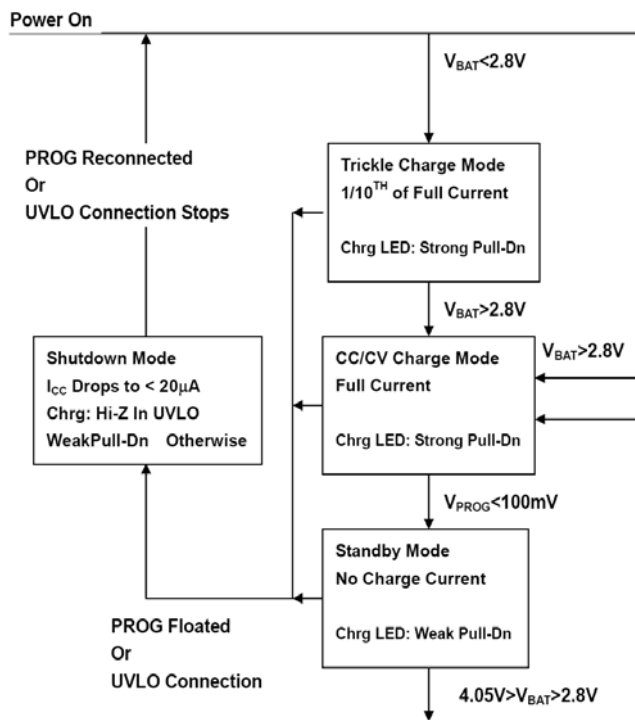

Application Hints

Stability Considerations

The constant-voltage mode feedback loop is stable without an output capacitor provided a battery is connected to the charger output. With no battery present, an output capacitor is recommended to reduce ripple voltage. When using high value, low ESR ceramic capacitors, it is recommended to add a 1Ω resistor in series with the capacitor. No series resistor is needed if tantalum capacitors are used. In constant-current mode, the PROG pin is in the feedback loop, not the battery. The constant-current mode stability is affected by the impedance at the PROG pin. With no additional capacitance on the PROG pin, the charger is stable with program resistor values as high as 20k. However, additional capacitance on this node reduces the maximum allowed program resistor. The pole frequency at the PROG pin should be kept above 100kHz.

Vcc Bypass Capacitor

Many types of capacitors can be used for input bypassing, however, caution must be exercised when using multilayer ceramic capacitors. Because of the self-resonant and high Q characteristics of some types of ceramic capacitors, high voltage transients can be generated under some start-up conditions, such as connecting the charger input to a live power source. Adding a 1.5Ω resistor in series with a ceramic capacitor will minimize start-up voltage transients.

Power Dissipation

The conditions that cause the YB1880 to reduce charge current through thermal feedback can be approximated by considering the power dissipated in the IC. Nearly all of this power dissipation is generated by the internal MOSFET—this is calculated to be approximately:

$$P_D = (V_{CC} - V_{BAT}) \cdot I_{BAT}$$

The approximate ambient temperature at which the thermal feedback begins to protect the IC is:

$$T_A = 120^\circ\text{C} - P_D \theta_{JA}$$

$$T_A = 120^\circ\text{C} - (V_{CC} - V_{BAT}) \cdot I_{BAT} \cdot \theta_{JA}$$

Thermal Considerations

Because of the small size of the thin SOT23 package, it is very important to use a good thermal PC board layout to maximize the available charge current. The thermal path for the heat generated by the IC is from the die to the copper lead frame, through the package lead, (especially the ground lead) to the PC board copper. The PC board copper is the heat sink. The footprint copper pads should be as wide as possible and expand out to larger copper areas to spread and dissipate the heat to the surrounding ambient. Other heat sources on the board, not related to the charger, must also be considered when designing a PC board layout because they will affect overall temperature rise and the maximum charge current.

Package Description

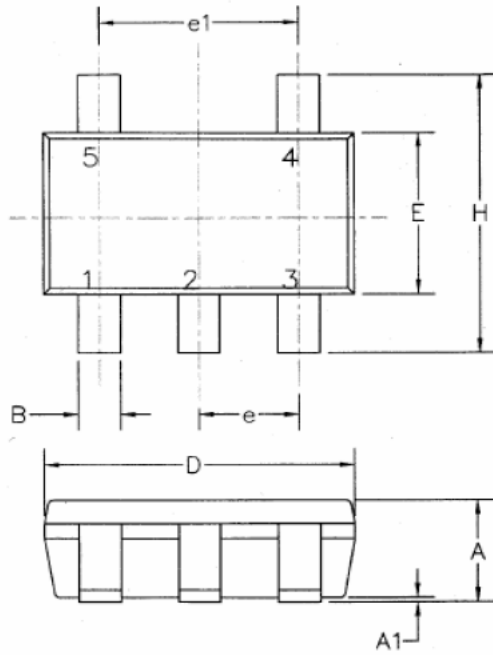

5LD SOT-23 PACKAGE OUTLINE DIMENSIONS
 ALL DIMENSIONS IN MM.

Dimension	Min.	Max.
A	0.9	1.10
A1	0.01	0.13
B	0.3	0.5
C	0.09	0.2
D	2.8	3.0
H	2.5	3.1
E	1.5	1.7
e	0.95 REF.	
e1	1.90 REF.	
L1	0.2	0.55
L	0.35	0.8
Q	0°	10°

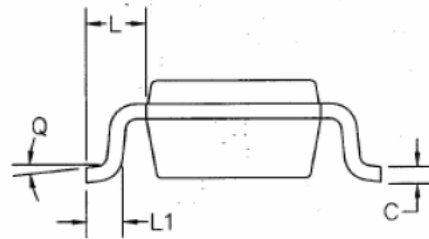

Note: Package outline exclusive of mold flash and metal burr.