

Inchange Semiconductor

Product Specification

Silicon NPN Power Transistors

2SC3387

DESCRIPTION

- With TO-3PN package
- High breakdown voltage
- Fast switching speed

APPLICATIONS

- For horizontal deflection output applications

PINNING

| PIN | DESCRIPTION |
|-----|--------------------------------------|
| 1 | Base |
| 2 | Collector;connected to mounting base |
| 3 | Emitter |

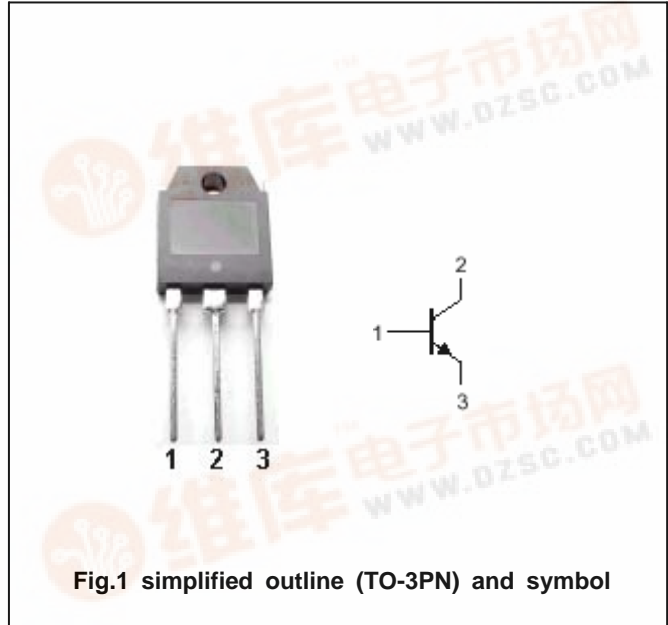

Fig.1 simplified outline (TO-3PN) and symbol

Absolute maximum ratings(Ta=°C)

| SYMBOL | PARAMETER | CONDITIONS | VALUE | UNIT |
|------------------|-----------------------------|----------------------|---------|------|
| V _{CBO} | Collector-base voltage | Open emitter | 1200 | V |
| V _{CEO} | Collector-emitter voltage | Open base | 500 | V |
| V _{EBO} | Emitter-base voltage | Open collector | 6 | V |
| I _C | Collector current | | 5 | A |
| I _{CM} | Collector current-peak | | 10 | A |
| P _C | Collector power dissipation | T _C =25°C | 50 | W |
| T _j | Junction temperature | | 150 | °C |
| T _{stg} | Storage temperature | | -55~150 | °C |

Silicon NPN Power Transistors

2SC3387

CHARACTERISTICS

T_j=25°C unless otherwise specified

| SYMBOL | PARAMETER | CONDITIONS | MIN | TYP. | MAX | UNIT |
|-----------------------|--------------------------------------|--|-----|------|-----|------|
| V _{CEQ(SUS)} | Collector-emitter sustaining voltage | I _C =100mA ; I _B =0 | 500 | | | V |
| V _{(BR)EBO} | Emitter-base breakdown voltage | I _E =1mA ; I _C =0 | 6 | | | V |
| V _{CEsat} | Collector-emitter saturation voltage | I _C =4A ; I _B =0.8A | | | 5.0 | V |
| V _{BEsat} | Base-emitter saturation voltage | I _C =4A ; I _B =0.8A | | | 1.5 | V |
| I _{CB0} | Collector cut-off current | V _{CB} =800V ; I _E =0 | | | 10 | μ A |
| I _{EBO} | Emitter cut-off current | V _{EB} =4V ; I _C =0 | | | 10 | μ A |
| h _{FE} | DC current gain | I _C =0.3A ; V _{CE} =5V | 15 | | | |

Silicon NPN Power Transistors

2SC3387

PACKAGE OUTLINE

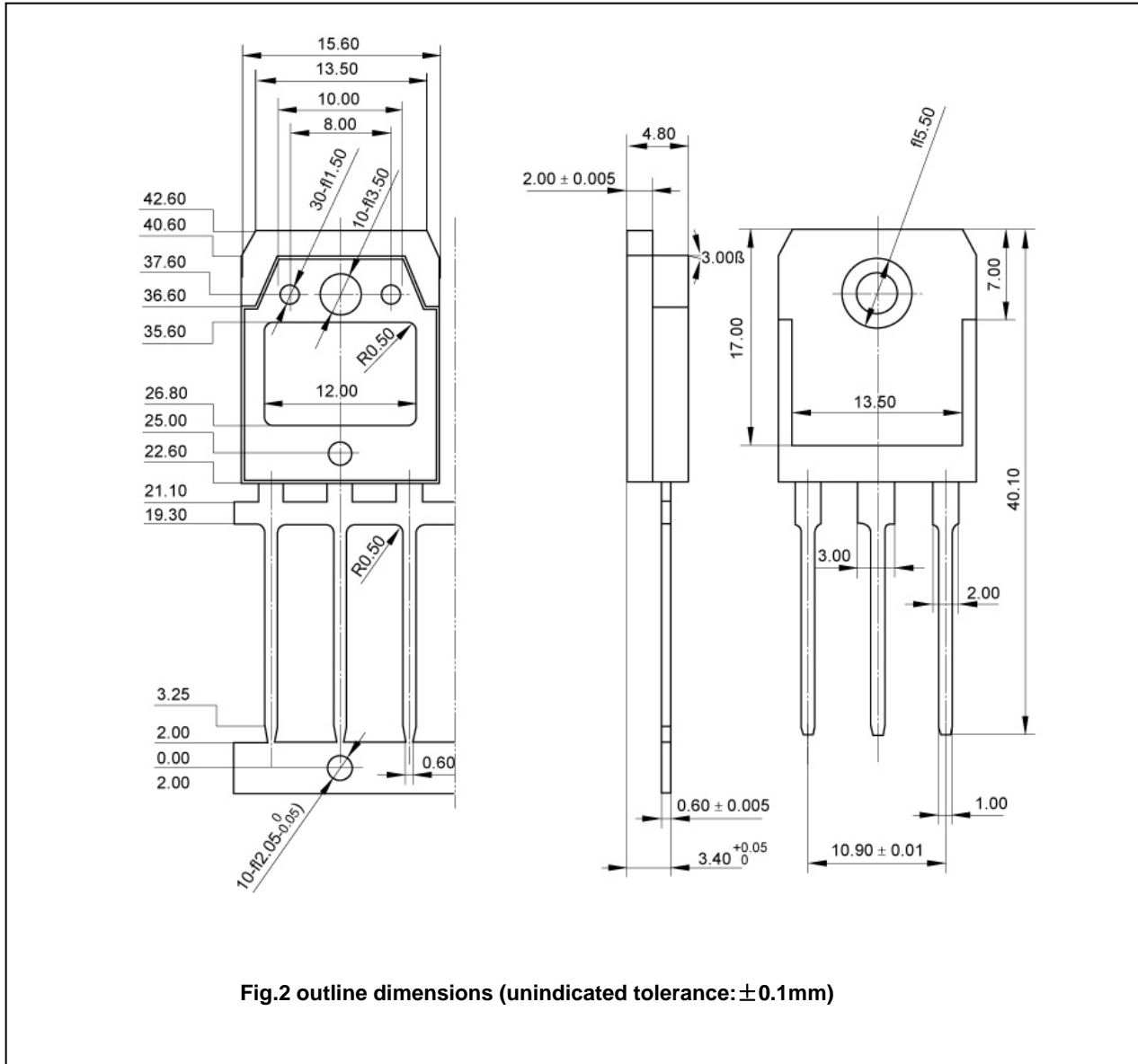

Fig.2 outline dimensions (unindicated tolerance: ± 0.1 mm)