

Silicon NPN Power Transistors

2SD315

DESCRIPTION

- With TO-66 package
- Complement to type 2SB509

APPLICATIONS

- For use in audio frequency power amplifier application

PINNING(see Fig.2)

PIN	DESCRIPTION
1	Base
2	Emitter
3	Collector

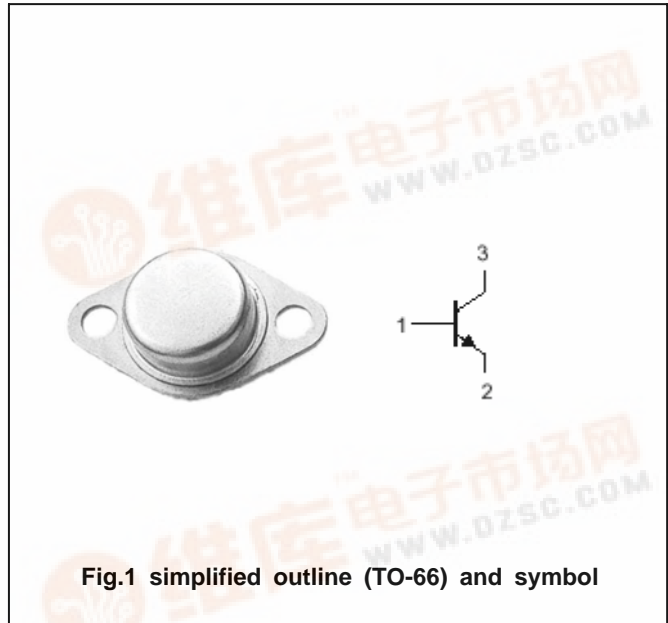

Fig.1 simplified outline (TO-66) and symbol

Absolute maximum ratings(Ta=℃)

SYMBOL	PARAMETER	CONDITIONS	VALUE	UNIT
V _{CBO}	Collector-base voltage	Open emitter	60	V
V _{CEO}	Collector-emitter voltage	Open base	60	V
V _{EBO}	Emitter-base voltage	Open collector	5	V
I _C	Collector current		4	A
I _{CM}	Collector current-peak		10	A
P _C	Collector power dissipation	T _C =25℃	35	W
T _j	Junction temperature		150	℃
T _{stg}	Storage temperature		-40~150	℃

Silicon NPN Power Transistors

2SD315

CHARACTERISTICS

T_j=25°C unless otherwise specified

SYMBOL	PARAMETER	CONDITIONS	MIN	TYP.	MAX	UNIT
V _{(BR)CEO}	Collector-emitter breakdown voltage	I _C =10mA ; I _B =0	60			V
V _{CEsat}	Collector-emitter saturation voltage	I _C =2A; I _B =0.2A			1.0	V
V _{BE}	Base-emitter on voltage	I _C =1A ; V _{CE} =2V			1.5	V
I _{CBO}	Collector cut-off current	V _{CB} =20V; I _E =0			0.1	mA
I _{EBO}	Emitter cut-off current	V _{EB} =4V; I _C =0			1.0	mA
h _{FE-1}	DC current gain	I _C =1A ; V _{CE} =2V	40		320	
h _{FE-2}	DC current gain	I _C =0.1A ; V _{CE} =2V	40			
f _T	Transition frequency	I _C =0.5A ; V _{CE} =5V		8		MHz

◆ h_{FE-1} Classifications

C	D	E	F
40-80	60-120	100-200	160-320

Silicon NPN Power Transistors

2SD315

PACKAGE OUTLINE

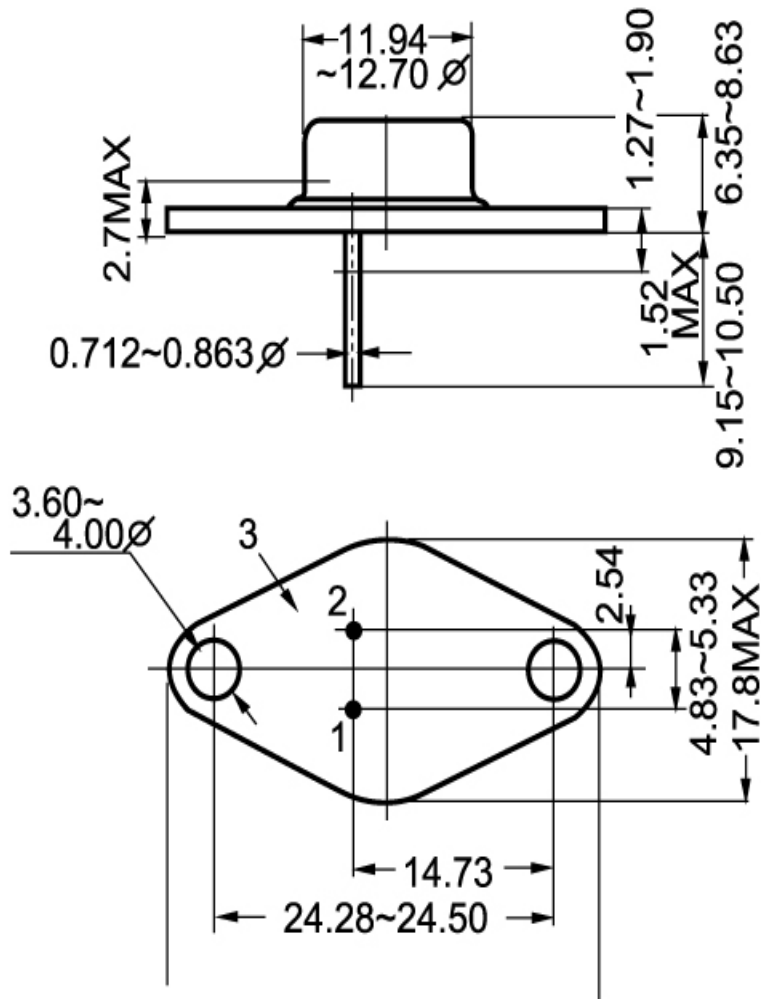

Fig.2 outline dimensions