

Silicon NPN Power Transistors

2SD362

DESCRIPTION

- With TO-220C package
- Collector-base voltage:  $V_{CBO}=150V$
- Collector current : $I_C=5A$
- Collector dissipation :  $P_C=40 (T_C=25^{\circ}C)$

APPLICATIONS

- For B/W TV horizontal deflection output applications

PINNING

PIN	DESCRIPTION
1	Base
2	Collector;connected to mounting base
3	Emitter

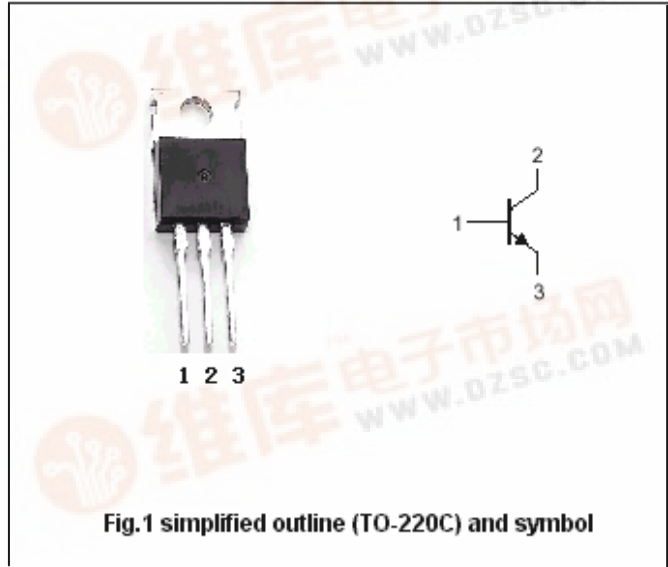

Fig.1 simplified outline (TO-220C) and symbol

Absolute maximum ratings( $T_a=25^{\circ}C$ )

SYMBOL	PARAMETER	CONDITIONS	VALUE	UNIT
$V_{CBO}$	Collector-base voltage	Open emitter	150	V
$V_{CEO}$	Collector-emitter voltage	Open base	70	V
$V_{EBO}$	Emitter-base voltage	Open collector	8	V
$I_C$	Collector current (DC)		5	A
$P_C$	Collector dissipation	$T_C=25^{\circ}C$	40	W
$T_j$	Junction temperature		150	$^{\circ}C$
$T_{stg}$	Storage temperature		-55~150	$^{\circ}C$

## Silicon NPN Power Transistors

## 2SD362

## CHARACTERISTICS

T<sub>j</sub>=25°C unless otherwise specified

SYMBOL	PARAMETER	CONDITIONS	MIN	TYP.	MAX	UNIT
V <sub>(BR)CBO</sub>	Collector-base breakdown voltage	I <sub>C</sub> =1mA; I <sub>E</sub> =0	150			V
V <sub>(BR)CEO</sub>	Collector-emitter breakdown voltage	I <sub>C</sub> =2mA; R <sub>BE</sub> =∞	70			V
V <sub>(BR)EBO</sub>	Emitter-base breakdown voltage	I <sub>E</sub> =1mA; I <sub>C</sub> =0	8			V
V <sub>CEsat</sub>	Collector-emitter saturation voltage	I <sub>C</sub> =5A; I <sub>B</sub> =0.5A			1.0	V
V <sub>BEsat</sub>	Base-emitter saturation voltage	I <sub>C</sub> =5A; I <sub>B</sub> =0.5A			1.5	V
I <sub>CBO</sub>	Collector cut-off current	V <sub>CB</sub> =100V; I <sub>E</sub> =0			20	μ A
I <sub>EBO</sub>	Emitter cut-off current	V <sub>EB</sub> =5V; I <sub>C</sub> =0			20	μ A
h <sub>FE</sub>	DC current gain	I <sub>C</sub> =5A ; V <sub>CE</sub> =5V	20		140	
f <sub>T</sub>	Transition frequency	I <sub>C</sub> =0.5A ; V <sub>CE</sub> =5V		10		MHz

◆ h<sub>FE</sub> classifications

N	R	O
20-50	40-80	70-140

Silicon NPN Power Transistors

2SD362

PACKAGE OUTLINE

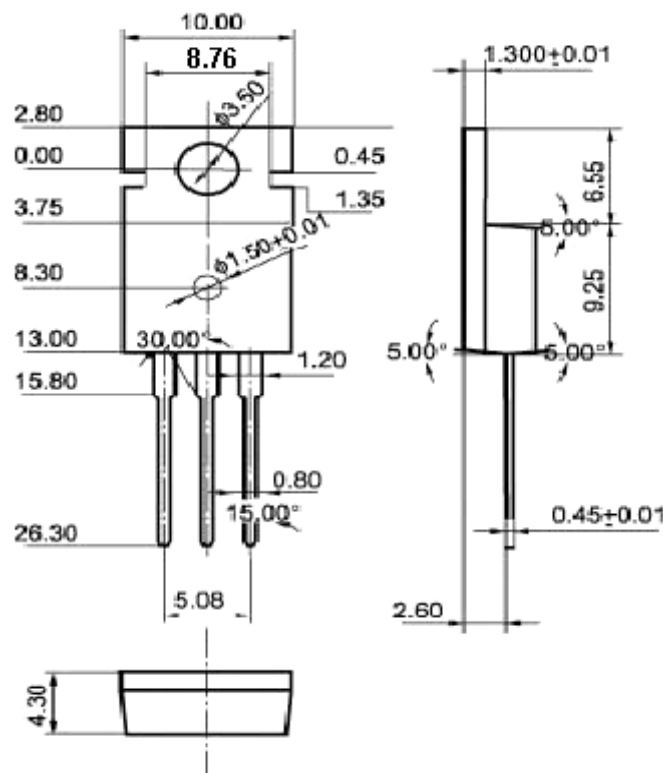

Fig.2 Outline dimensions (unindicated tolerance: ±0.10mm)

Silicon NPN Power Transistors

2SD362

