

INCHANGE Semiconductor

isc Product Specification

isc Silicon PNP Power Transistor

BD744B

DESCRIPTION

- Collector-Emitter Breakdown Voltage-
: $V_{(BR)CEO} = -80V(\text{Min})$
- Collector Power Dissipation-
: $P_C = 90W @ I_C = 25^\circ C$
- 15A Continuous Collector Current
- Complement to Type BD743B

APPLICATIONS

- Designed for use in general purpose power amplifier and switching applications.

ABSOLUTE MAXIMUM RATINGS($T_a=25^\circ C$)

SYMBOL	PARAMETER	VALUE	UNIT
V_{CBO}	Collector-Base Voltage	-90	V
V_{CEO}	Collector-Emitter Voltage	-80	V
V_{EBO}	Emitter-Base Voltage	-5	V
I_C	Collector Current-Continuous	-15	A
I_{CM}	Collector Current-Peak	-20	A
I_B	Base Current-Continuous	-5	A
P_C	Collector Power Dissipation @ $T_a=25^\circ C$	2	W
	Collector Power Dissipation @ $T_C=25^\circ C$	90	
T_J	Junction Temperature	150	$^\circ C$
T_{stg}	Storage Temperature Range	-65~150	$^\circ C$

THERMAL CHARACTERISTICS

SYMBOL	PARAMETER	MAX	UNIT
$R_{th\ j-c}$	Thermal Resistance, Junction to Case	1.4	$^\circ C/W$
$R_{th\ j-a}$	Thermal Resistance, Junction to Ambient	62.5	$^\circ C/W$

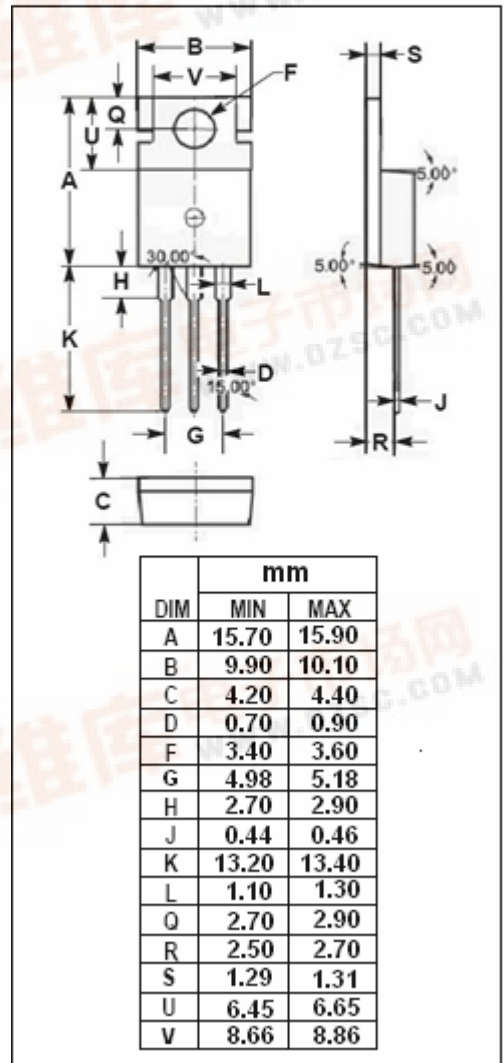
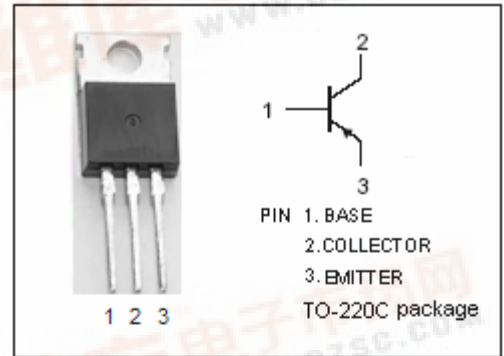

isc Silicon PNP Power Transistor

BD744B

ELECTRICAL CHARACTERISTICS

 $T_C=25^{\circ}\text{C}$ unless otherwise specified

SYMBOL	PARAMETER	CONDITIONS	MIN	MAX	UNIT
$V_{(BR)CEO}$	Collector-Emitter Breakdown Voltage	$I_C = -30\text{mA}; I_B = 0$	-80		V
$V_{CE(sat)-1}$	Collector-Emitter Saturation Voltage	$I_C = -5\text{A}; I_B = -0.5\text{A}$		-1.0	V
$V_{CE(sat)-2}$	Collector-Emitter Saturation Voltage	$I_C = -15\text{A}; I_B = -5\text{A}$		-3.0	V
$V_{BE(on)-1}$	Base-Emitter On Voltage	$I_C = -5\text{A}; V_{CE} = -4\text{V}$		-1.0	V
$V_{BE(on)-2}$	Base-Emitter On Voltage	$I_C = -15\text{A}; V_{CE} = -4\text{V}$		-3.0	V
I_{CBO}	Collector Cutoff Current	$V_{CB} = -90\text{V}; I_E = 0$		-0.1	mA
		$V_{CB} = -90\text{V}; I_E = 0; T_C = 125^{\circ}\text{C}$		-5.0	
I_{CEO}	Collector Cutoff Current	$V_{CE} = -60\text{V}; I_B = 0$		-0.1	mA
I_{EBO}	Emitter Cutoff Current	$V_{EB} = -5\text{V}; I_C = 0$		-0.5	mA
h_{FE-1}	DC Current Gain	$I_C = -1\text{A}; V_{CE} = -4\text{V}$	40		
h_{FE-2}	DC Current Gain	$I_C = -5\text{A}; V_{CE} = -4\text{V}$	20	150	
h_{FE-3}	DC Current Gain	$I_C = -15\text{A}; V_{CE} = -4\text{V}$	5		

Switching Times

t_d	Delay Time	$I_C = -5\text{A}; I_{B1} = -I_{B2} = -5\text{A};$ $V_{BE(off)} = 4.2\text{V}; R_L = 6\ \Omega;$ $t_p = 20\ \mu\text{s}, \text{DutyCycle} \leq 2\%$		20		ns
t_r	Rise Time			120		ns
t_s	Storage Time			600		ns
t_f	Fall time			300		ns