

SavantIC Semiconductor

Product Specification

Silicon NPN Power Transistors

2N6288 2N6290 2N6292

DESCRIPTION

- With TO-220 package
- Complement to PNP type:  
2N6107; 2N6109 ;2N6111

APPLICATIONS

- Power amplifier and switching circuits applications

PINNING

PIN	DESCRIPTION
1	Base
2	Collector;connected to mounting base
3	Emitter

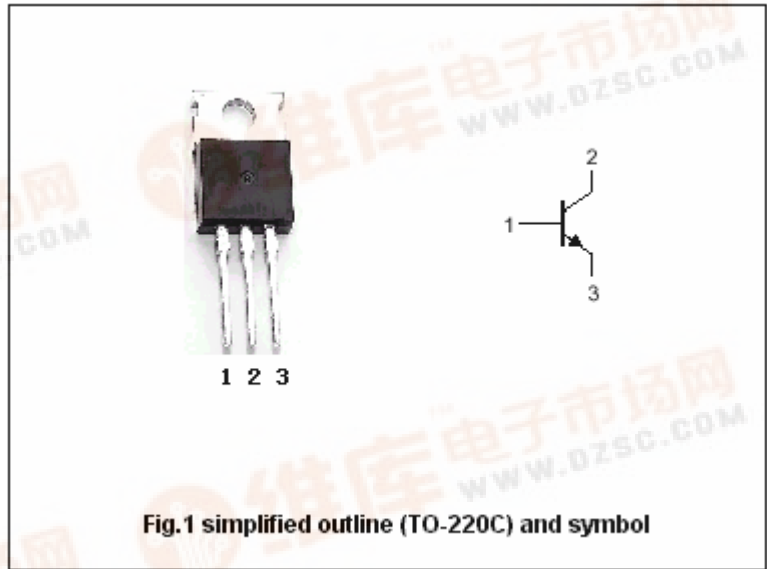

Absolute maximum ratings(Ta=25°C)

SYMBOL	PARAMETER	CONDITIONS	VALUE	UNIT
V <sub>CBO</sub>	Collector-base voltage	2N6288	40	V
		2N6290	60	
		2N6292	80	
V <sub>CEO</sub>	Collector-emitter voltage	2N6288	30	V
		2N6290	50	
		2N6292	70	
V <sub>EBO</sub>	Emitter-base voltage	Open collector	5	V
I <sub>C</sub>	Collector current		7	A
I <sub>CM</sub>	Collector current-peak		10	A
I <sub>B</sub>	Base current		3	A
P <sub>T</sub>	Total power dissipation	T <sub>C</sub> =25°C	40	W
T <sub>j</sub>	Junction temperature		150	°C
T <sub>stg</sub>	Storage temperature		-65~150	°C

THERMAL CHARACTERISTICS

SYMBOL	PARAMETER	MAX	UNIT
R <sub>th j-c</sub>	Thermal resistance from junction to case	3.125	°C/W

## Silicon NPN Power Transistors

## 2N6288 2N6290 2N6292

## CHARACTERISTICS

T<sub>j</sub>=25°C unless otherwise specified

SYMBOL	PARAMETER	CONDITIONS	MIN	TYP.	MAX	UNIT	
V <sub>CE0(SUS)</sub>	Collector-emitter sustaining voltage	2N6288	I <sub>C</sub> =0.1A ; I <sub>B</sub> =0	30			V
		2N6290		50			
		2N6292		70			
V <sub>CEsat-1</sub>	Collector-emitter saturation voltage	2N6288	I <sub>C</sub> =3A; I <sub>B</sub> =0.3A		1.0	V	
		2N6290	I <sub>C</sub> =2.5A; I <sub>B</sub> =0.25A				
		2N6292	I <sub>C</sub> =2A; I <sub>B</sub> =0.2A				
V <sub>CEsat-2</sub>	Collector-emitter saturation voltage	I <sub>C</sub> =7A; I <sub>B</sub> =3A			3.5	V	
V <sub>BE-1</sub>	Base-emitter on voltage	2N6288	I <sub>C</sub> =3A ; V <sub>CE</sub> =4V		1.5	V	
		2N6290	I <sub>C</sub> =2.5A ; V <sub>CE</sub> =4V				
		2N6292	I <sub>C</sub> =2A ; V <sub>CE</sub> =4V				
V <sub>BE-2</sub>	Base-emitter on voltage	I <sub>C</sub> =7A ; V <sub>CE</sub> =4V			3.0	V	
I <sub>CEO</sub>	Collector cut-off current	2N6288	V <sub>CE</sub> =20V; I <sub>B</sub> =0		1.0	mA	
		2N6290	V <sub>CE</sub> =40V; I <sub>B</sub> =0				
		2N6292	V <sub>CE</sub> =60V; I <sub>B</sub> =0				
I <sub>CEX</sub>	Collector cut-off current	2N6288	V <sub>CE</sub> =40V; V <sub>BE</sub> =-1.5V V <sub>CE</sub> =30V; V <sub>BE</sub> =-1.5V, T <sub>C</sub> =125°C		0.1 2.0	mA	
		2N6290	V <sub>CE</sub> =60V; V <sub>BE</sub> =-1.5V V <sub>CE</sub> =50V; V <sub>BE</sub> =-1.5V, T <sub>C</sub> =125°C		0.1 2.0		
		2N6292	V <sub>CE</sub> =80V; V <sub>BE</sub> =-1.5V V <sub>CE</sub> =70V; V <sub>BE</sub> =-1.5V, T <sub>C</sub> =125°C		0.1 2.0		
I <sub>EBO</sub>	Emitter cut-off current	V <sub>EB</sub> =5V; I <sub>C</sub> =0			1.0	mA	
h <sub>FE-1</sub>	DC current gain	2N6288	I <sub>C</sub> =3A ; V <sub>CE</sub> =4V	30	150		
		2N6290	I <sub>C</sub> =2.5A ; V <sub>CE</sub> =4V				
		2N6292	I <sub>C</sub> =2A ; V <sub>CE</sub> =4V				
h <sub>FE-2</sub>	DC current gain	I <sub>C</sub> =7A ; V <sub>CE</sub> =4V	2.3				
f <sub>T</sub>	Transition frequency	I <sub>C</sub> =0.5A ; V <sub>CE</sub> =4V; f=1MHz	2.5			MHz	

Silicon NPN Power Transistors

2N6288 2N6290 2N6292

PACKAGE OUTLINE

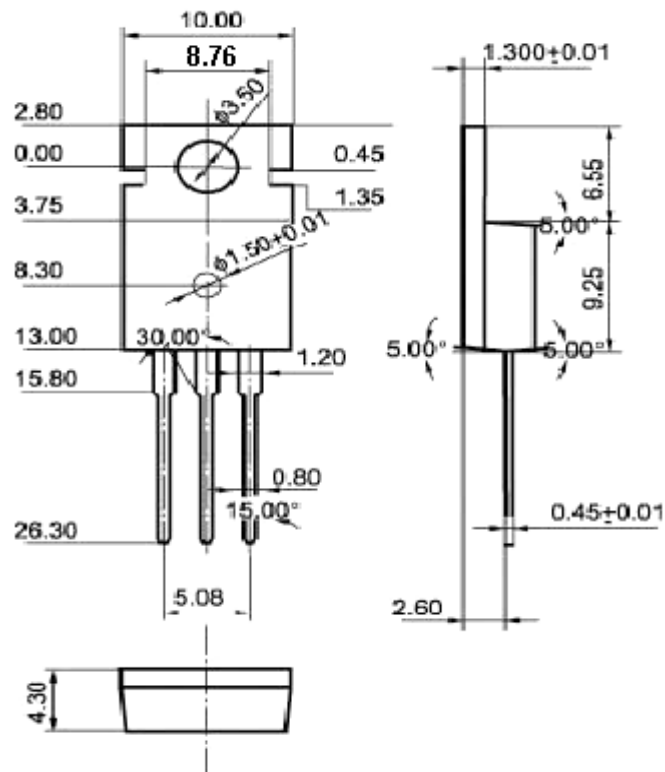

Fig.2 Outline dimensions(unindicated tolerance:±0.10 mm)