

SavantIC Semiconductor

Product Specification

Silicon NPN Power Transistors

2N6931 2N6932

DESCRIPTION

- With TO-3PN package
- High voltage ,high speed

APPLICATIONS

- Off-line power supplies
- High-voltage inverters
- Switching regulators

PINNING

PIN	DESCRIPTION
1	Base
2	Collector;connected to mounting base
3	Emitter

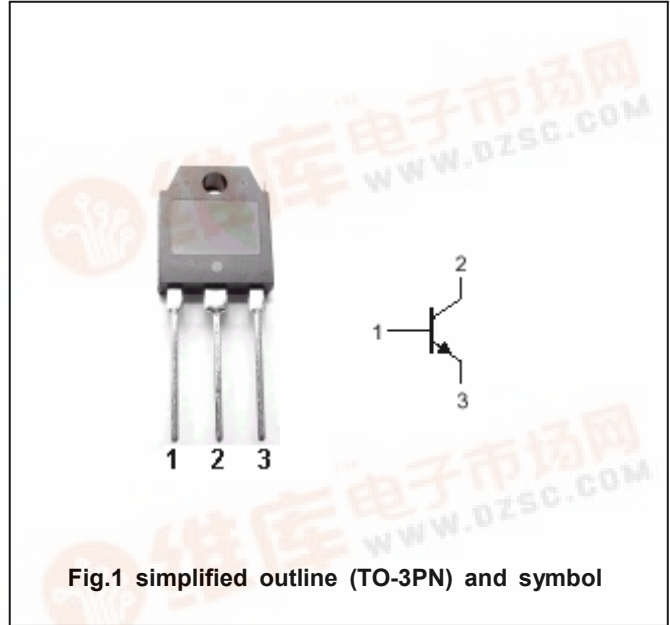

Fig.1 simplified outline (TO-3PN) and symbol

Absolute maximum ratings (Ta=25°C)

SYMBOL	PARAMETER	CONDITIONS	VALUE	UNIT
V _{CBO}	Collector-base voltage	2N6931	450	V
		2N6932	650	
V _{CEO}	Collector-emitter voltage	2N6931	300	V
		2N6932	400	
V _{EBO}	Emitter-base voltage	Open collector	8	V
I _C	Collector current		10	A
I _{CM}	Collector current-peak		15	A
I _B	Base current		5	A
I _{BM}	Base current-peak		7	A
I _E	Emitter current		15	A
I _{EM}	Emitter current-peak		22	A
P _C	Collector power dissipation	T _C =25°C	150	W
T _j	Junction temperature		150	°C
T _{stg}	Storage temperature		-65~150	°C

Silicon NPN Power Transistors

2N6931 2N6932

CHARACTERISTICS

T_j=25°C unless otherwise specified

SYMBOL	PARAMETER	CONDITIONS	MIN	TYP.	MAX	UNIT
V _{CEO(SUS)}	Collector-emitter sustaining voltage	2N6931	I _C =0.2A ; L=25mH			V
		2N6932				
V _{(BR)EBO}	Emitter-base breakdown voltage	I _E =50mA ; I _C =0	8			V
V _{CEsat}	Collector-emitter saturation voltage	I _C =10A ; I _B =2A T _C =100°C			1.0 2.0	V
V _{BEsat}	Base-emitter saturation voltage	I _C =10A ; I _B =2A T _C =100°C			1.5 1.5	V
I _{CEV}	Collector cut-off current	2N6931	V _{CE} =450V ; V _{BE} =-1.5V T _C =100°C		0.1 1.0	mA
		2N6932				
I _{EBO}	Emitter cut-off current	V _{EB} =8V ; I _C =0			2	mA
h _{FE}	DC current gain	I _C =10A ; V _{CE} =3V	8		35	
C _{OB}	Collector output capacitance	f=1MHz ; V _{CB} =10V	80		300	pF

Switching times resistive load

t _d	Delay time	I _C =10A ; I _{B1} =-I _{B2} =2A V _{CC} =300V, R _C =30Ω V _{BB} =-5V ; t _p =30μs			0.1	μs
t _r	Rise time				0.7	μs
t _{stg}	Storage time				2.5	μs
t _f	Fall time				0.5	μs

THERMAL CHARACTERISTICS

SYMBOL	PARAMETER	VALUE	UNIT
R _{th j-c}	Thermal resistance junction to case	0.83	°C/W

Silicon NPN Power Transistors

2N6931 2N6932

PACKAGE OUTLINE

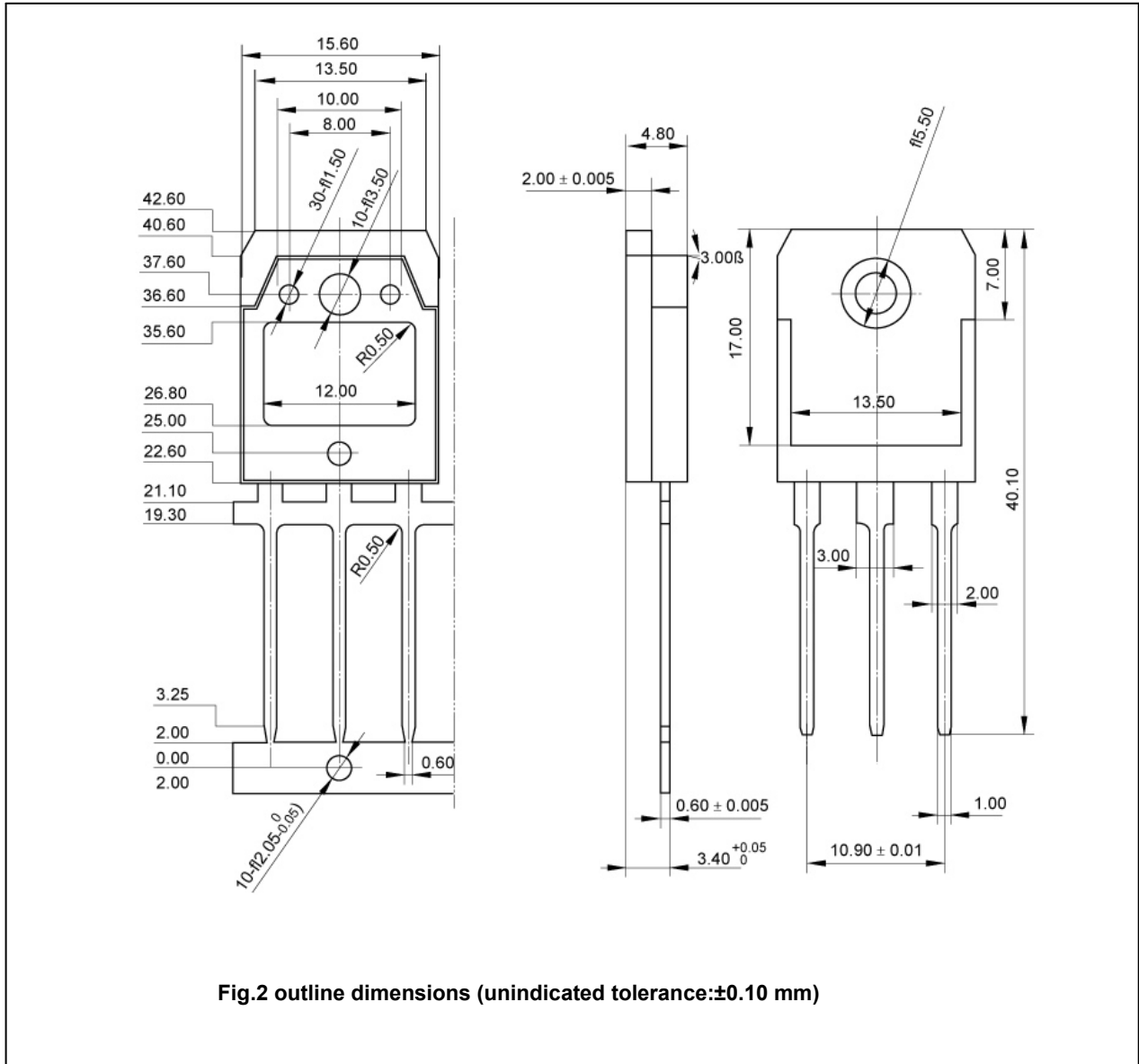

Fig.2 outline dimensions (unindicated tolerance:±0.10 mm)