

SavantIC Semiconductor

Product Specification

Silicon PNP Power Transistors

2SB1490

DESCRIPTION

- With TO-3PL package
- Complement to type 2SD2250
- High DC current gain
- Low collector saturation voltage
- DARLINGTON

APPLICATIONS

- For power amplification
- Optimum for HiFi output applications

PINNING

PIN	DESCRIPTION
1	Base
2	Collector;connected to mounting base
3	Emitter

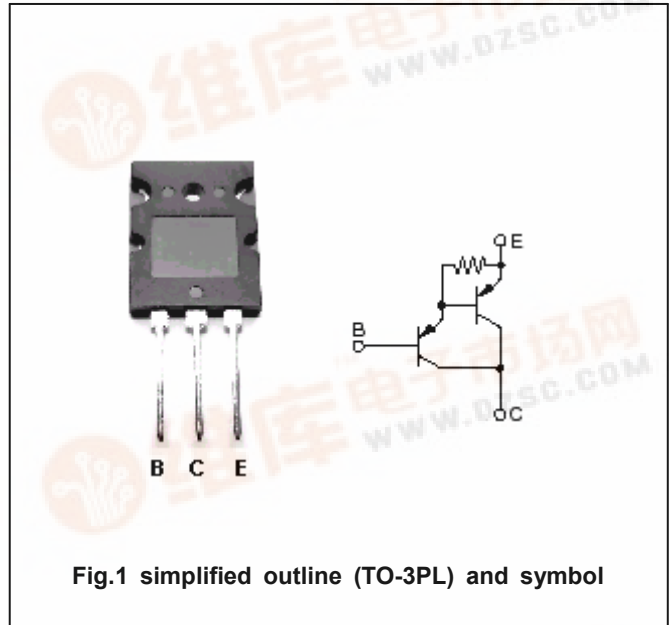

Fig.1 simplified outline (TO-3PL) and symbol

Absolute maximum ratings(Ta=25°C)

SYMBOL	PARAMETER	CONDITIONS	VALUE	UNIT
V _{CBO}	Collector-base voltage	Open emitter	-160	V
V _{CEO}	Collector-emitter voltage	Open base	-140	V
V _{EBO}	Emitter-base voltage	Open collector	-5	V
I _C	Collector current		-7	A
I _{CM}	Collector current-peak		-12	A
P _C	Collector power dissipation	T _C =25°C	90	W
		T _a =25°C	3.5	
T _j	Junction temperature		150	°C
T _{stg}	Storage temperature		-55~150	°C

Silicon PNP Power Transistors

2SB1490

CHARACTERISTICS

T_j=25°C unless otherwise specified

SYMBOL	PARAMETER	CONDITIONS	MIN	TYP.	MAX	UNIT
V _{(BR)CEO}	Collector-emitter breakdown voltage	I _C =-30mA ; I _B =0	-140			V
V _{CEsat}	Collector-emitter saturation voltage	I _C =-6A ; I _B =-6mA			-2.5	V
V _{BEsat}	Base-emitter saturation voltage	I _C =-6A ; I _B =-6mA			-3.0	V
I _{CBO}	Collector cut-off current	V _{CB} =-160V ; I _E =0			-100	μA
I _{CEO}	Collector cut-off current	V _{CE} =-140V ; I _B =0			-100	μA
I _{EBO}	Emitter cut-off current	V _{EB} =-5V ; I _C =0			-100	μA
h _{FE-1}	DC current gain	I _C =-1A ; V _{CE} =-5V	2000			
h _{FE-2}	DC current gain	I _C =-6A ; V _{CE} =-5V	5000		30000	
f _T	Transition frequency	I _C =-0.5A ; V _{CE} =-10V ; f=1MHz		20		MHz

Switching times

t _{on}	Turn-on time	I _C =-6A ; I _{B1} =-I _{B2} =-6mA V _{CC} =-50V		1.0		μs
t _s	Storage time			1.5		μs
t _f	Fall time			1.2		μs

◆ h_{FE-2} classifications

Q	P
5000-150000	8000-30000

Silicon PNP Power Transistors

2SB1490

PACKAGE OUTLINE

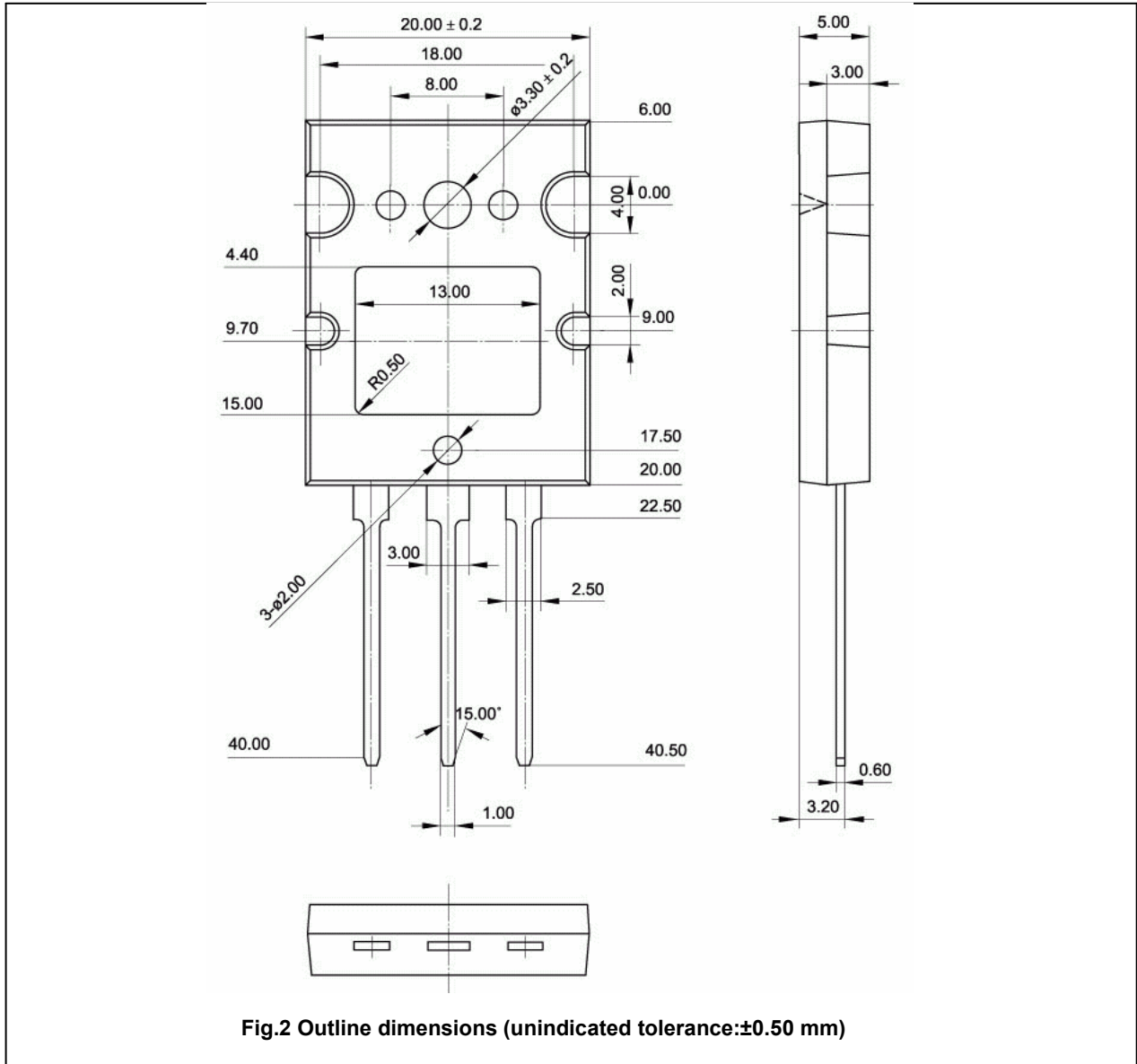

Fig.2 Outline dimensions (unindicated tolerance:±0.50 mm)