

SavantIC Semiconductor

Product Specification

Silicon PNP Darlington Power Transistors

2SB1625

DESCRIPTION

- With TO-3PML package
- Complement to type 2SD2494

APPLICATIONS

- Audio ,regulator and general purpose

PINNING

PIN	DESCRIPTION
1	Base
2	Collector
3	Emitter

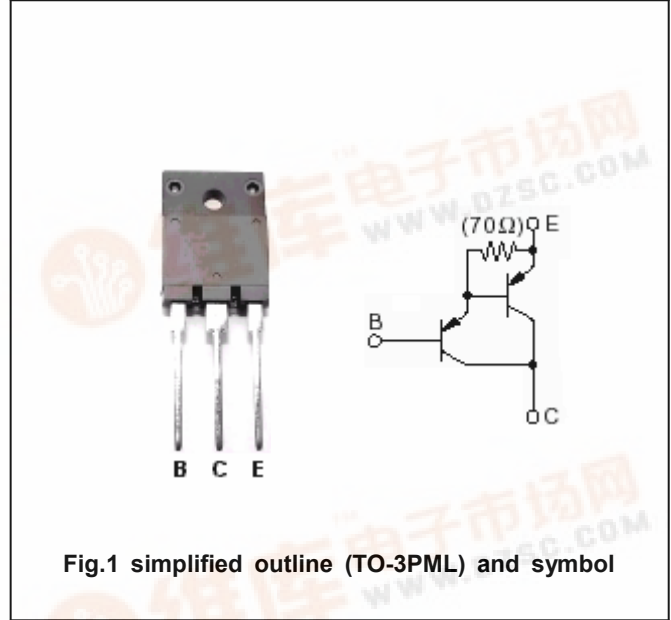

Maximum absolute ratings(Tc=25℃)

SYMBOL	PARAMETER	CONDITIONS	VALUE	UNIT
V _{CBO}	Collector-base voltage	Open emitter	-110	V
V _{CEO}	Collector-emitter voltage	Open base	-110	V
V _{EBO}	Emitter-base voltage	Open collector	-5	V
I _C	Collector current		-6	A
I _B	Base current		-1	A
P _C	Collector power dissipation	T _C =25℃	60	W
T _j	Junction temperature		150	℃
T _{stg}	Storage temperature		-55~150	℃

Silicon PNP Darlington Power Transistors

2SB1625

CHARACTERISTICS

T_j=25°C unless otherwise specified

SYMBOL	PARAMETER	CONDITIONS	MIN	TYP.	MAX	UNIT
V _{CEO}	Collector-emitter breakdown voltage	I _C =-50mA; I _B =0	-110			V
V _{CEsat}	Collector-emitter saturation voltage	I _C =-5 A; I _B =-5m A			-2.5	V
V _{BEsat}	Base-emitter saturation voltage	I _C =-5 A; I _B =-5m A			-3.0	V
I _{CBO}	Collector cut-off current	V _{CB} =-110V; I _E =0			-100	μA
I _{EBO}	Emitter cut-off current	V _{EB} =-5V; I _C =0			-100	μA
h _{FE}	DC current gain	I _C =-5A ; V _{CE} =-4V	5000			
f _T	Transition frequency	I _C =0.5A ; V _{CE} =-12V		100		MHz
C _{OB}	Output capacitance	I _E =0; V _{CB} =-10V; f=1MHz		110		pF

Switching times

t _{on}	Turn-on time	I _C =-5A; R _L =6Ω I _{B1} =-I _{B2} =-5mA V _{CC} =-30V		1.1		μs
t _s	Storage time			3.2		μs
t _f	Fall time			1.1		μs

◆ h_{FE} classifications

O	P	Y
5000-12000	6500-20000	15000-30000

Silicon PNP Darlington Power Transistors

2SB1625

PACKAGE OUTLINE

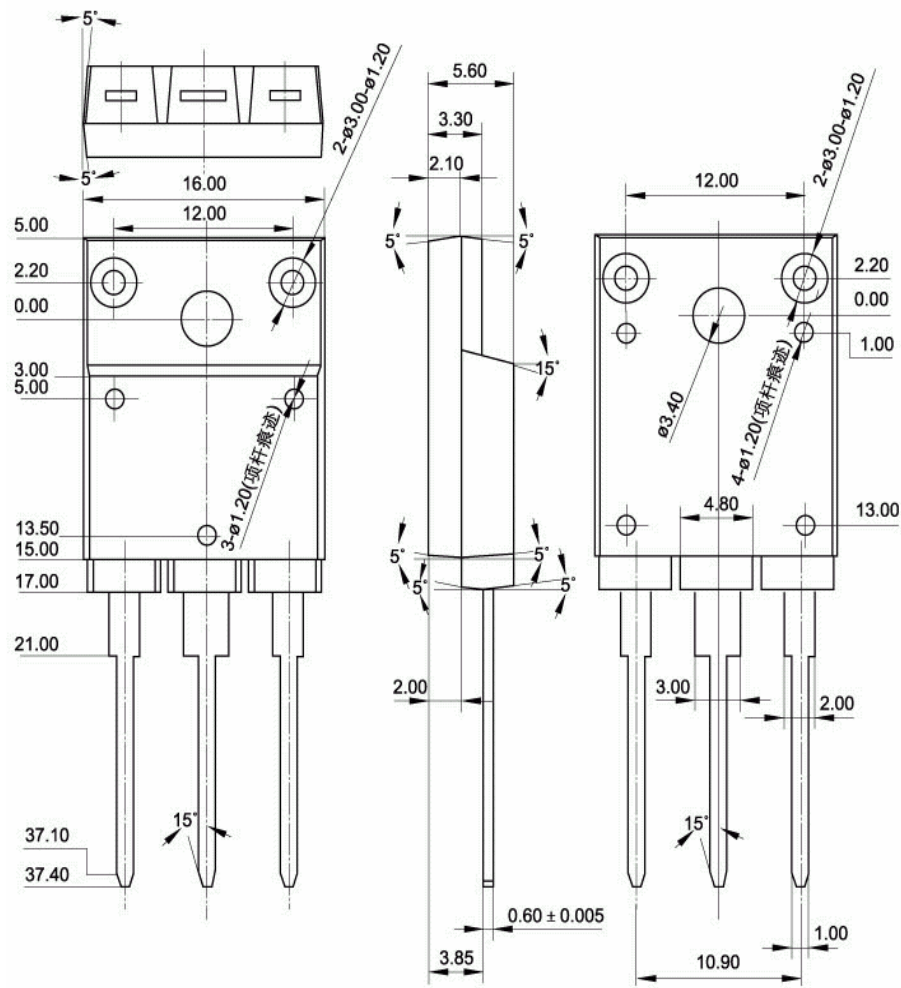

Fig.2 Outline dimensions