

SavantIC Semiconductor

Product Specification

Silicon NPN Power Transistors

2SD727

DESCRIPTION

- With TO-3PN package
- Complement to type 2SB691

APPLICATIONS

- For low frequency power amplifier and power switching applications

PINNING

PIN	DESCRIPTION
1	Base
2	Collector;connected to mounting base
3	Emitter

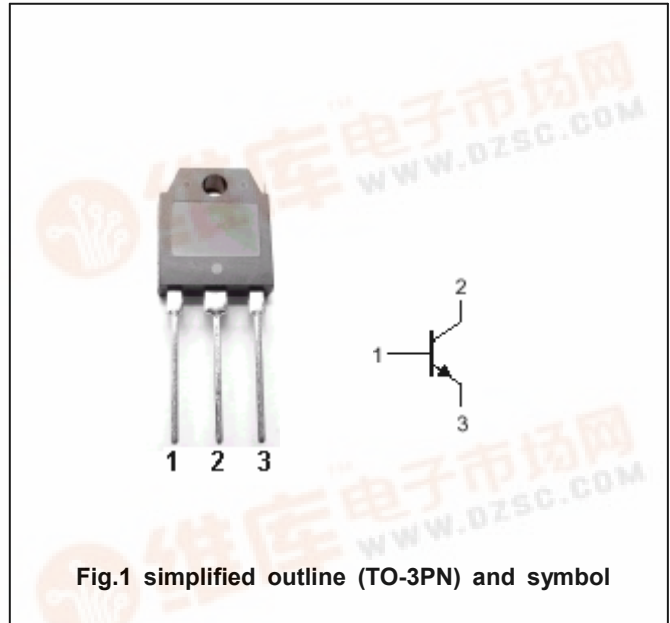

Absolute maximum ratings(Ta=25°C)

SYMBOL	PARAMETER	CONDITIONS	VALUE	UNIT
V _{CBO}	Collector-base voltage	Open emitter	130	V
V _{CEO}	Collector-emitter voltage	Open base	130	V
V _{EBO}	Emitter-base voltage	Open collector	5	V
I _C	Collector current		5	A
P _C	Collector power dissipation	T _c =25°C	60	W
T _j	Junction temperature		150	°C
T _{stg}	Storage temperature		-55~150	°C

Silicon NPN Power Transistors

2SD727

CHARACTERISTICS

T_j=25 °C unless otherwise specified

SYMBOL	PARAMETER	CONDITIONS	MIN	TYP.	MAX	UNIT
V _{(BR)CEO}	Collector-emitter breakdown voltage	I _C =50mA ; I _B =0	130			V
V _{(BR)EBO}	Emitter-base breakdown voltage	I _E =1mA ; I _C =0	5			V
V _{CEsat}	Collector-emitter saturation voltage	I _C =5A ; I _B =0.5A			2.5	V
I _{CBO}	Collector cut-off current	V _{CB} =130V ; I _E =0			0.1	mA
I _{EBO}	Emitter cut-off current	V _{EB} =5V ; I _C =0			0.1	mA
h _{FE-1}	DC current gain	I _C =1A ; V _{CE} =5V	60		200	
h _{FE-2}	DC current gain	I _C =4A ; V _{CE} =5V	20			
f _T	Transition frequency	I _C =1A ; V _{CE} =5V		7		MHz
C _{OB}	Collector output capacitance	I _E =0 ; f=1MHz ; V _{CB} =10V		110		pF

Silicon NPN Power Transistors

2SD727

PACKAGE OUTLINE

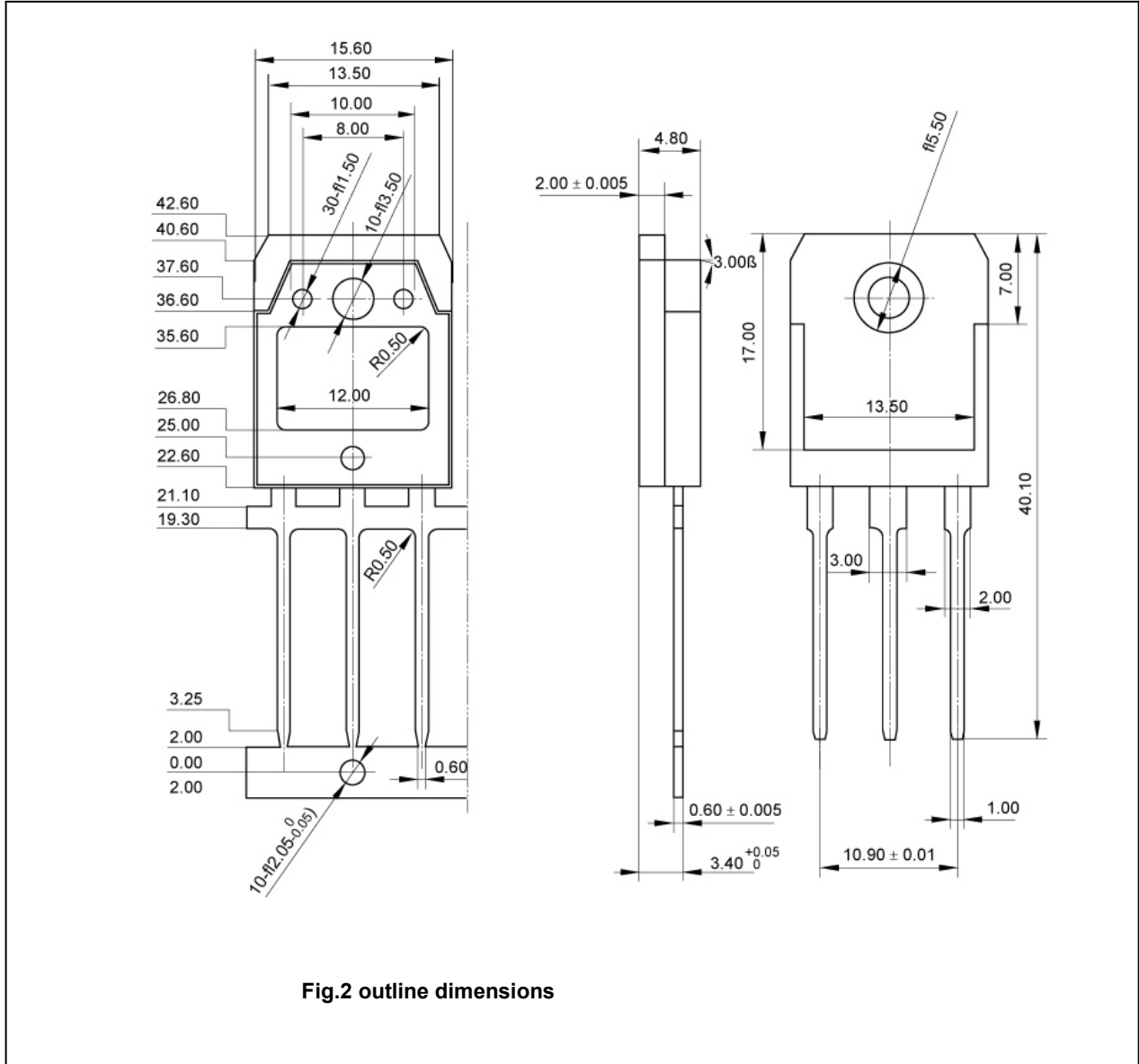

Fig.2 outline dimensions