

Silicon NPN Power Transistors

2SD768

DESCRIPTION

- With TO-220C package
- Complement to type 2SB727
- DARLINGTON

APPLICATIONS

- For medium speed and power switching applications

PINNING

PIN	DESCRIPTION
1	Base
2	Collector;connected to mounting base
3	Emitter

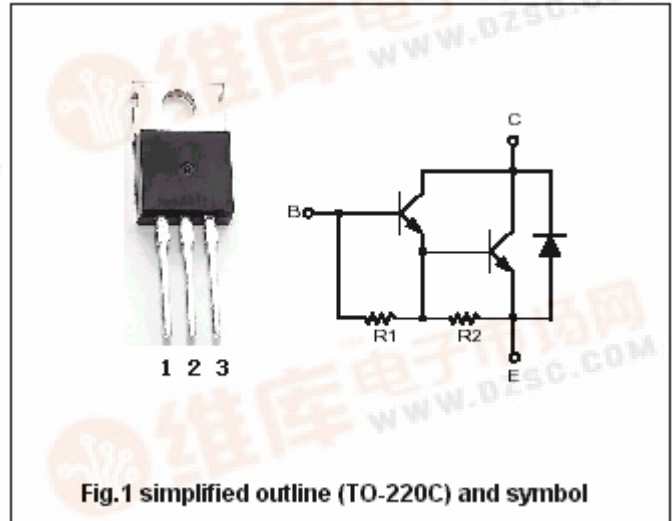

Absolute maximum ratings(Ta=25°C)

SYMBOL	PARAMETER	CONDITIONS	VALUE	UNIT
V <sub>CBO</sub>	Collector-base voltage	Open emitter	120	V
V <sub>CEO</sub>	Collector-emitter voltage	Open base	120	V
V <sub>EBO</sub>	Emitter-base voltage	Open collector	7	V
I <sub>C</sub>	Collector current		6	A
I <sub>CM</sub>	Collector current-Peak		10	A
P <sub>C</sub>	Collector dissipation	T <sub>C</sub> =25°C	40	W
T <sub>j</sub>	Junction temperature		150	°C
T <sub>stg</sub>	Storage temperature		-50~150	°C

## Silicon NPN Power Transistors

## 2SD768

## CHARACTERISTICS

T<sub>j</sub>=25°C unless otherwise specified

SYMBOL	PARAMETER	CONDITIONS	MIN	TYP.	MAX	UNIT
V <sub>(BR)CEO</sub>	Collector-emitter breakdown voltage	I <sub>C</sub> =25mA; R <sub>BE</sub> =∞	120			V
V <sub>(BR)EBO</sub>	Emitter-base breakdown voltage	I <sub>E</sub> =50mA; I <sub>C</sub> =0	7			V
V <sub>CEsat-1</sub>	Collector-emitter saturation voltage	I <sub>C</sub> =3A; I <sub>B</sub> =6mA			1.5	V
V <sub>CEsat-2</sub>	Collector-emitter saturation voltage	I <sub>C</sub> =6A; I <sub>B</sub> =60mA			3.0	V
V <sub>BEsat-1</sub>	Base-emitter saturation voltage	I <sub>C</sub> =3A; I <sub>B</sub> =6mA			2.0	V
V <sub>BEsat-2</sub>	Base-emitter saturation voltage	I <sub>C</sub> =6A; I <sub>B</sub> =60mA			3.5	V
I <sub>CBO</sub>	Collector cut-off current	V <sub>CB</sub> =120V; I <sub>E</sub> =0			100	μA
I <sub>CEO</sub>	Collector cut-off current	V <sub>CE</sub> =100V; R <sub>BE</sub> =∞			10	μA
h <sub>FE</sub>	DC current gain	I <sub>C</sub> =3A; V <sub>CE</sub> =3V	1000		20000	

## Switching times

t <sub>on</sub>	Turn-on time	I <sub>C</sub> =3A; I <sub>B1</sub> =-I <sub>B2</sub> =6mA		1.0		μs
t <sub>off</sub>	Turn-off time			3.0		μs

Silicon NPN Power Transistors

2SD768

PACKAGE OUTLINE

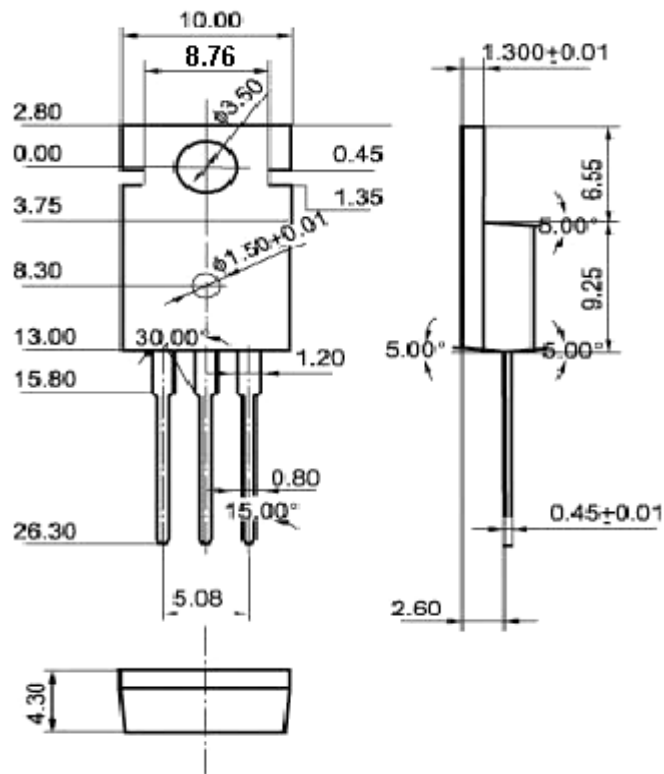

Fig.2 Outline dimensions (unindicated tolerance:±0.10mm)