

Silicon NPN Power Transistors

2SD772 2SD772A 2SD772B

DESCRIPTION

- With TO-220C package
- High breakdown voltage
- High speed switching

APPLICATIONS

- For power amplifier applications

PINNING

PIN	DESCRIPTION
1	Base
2	Collector;connected to mounting base
3	Emitter

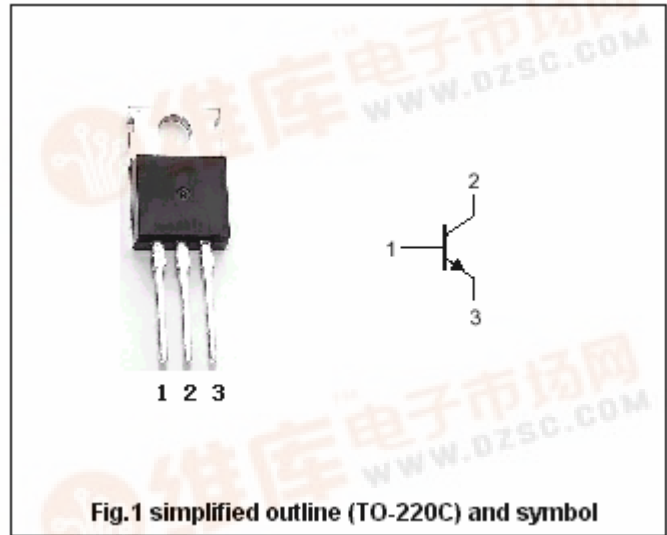

Absolute maximum ratings(Ta=25°C)

SYMBOL	PARAMETER	CONDITIONS	VALUE	UNIT
V <sub>CBO</sub>	Collector-base voltage	2SD772	150	V
		2SD772A	200	
		2SD772B	250	
V <sub>CEO</sub>	Collector-emitter voltage	Open base	80	V
V <sub>EBO</sub>	Emitter-base voltage	Open collector	6	V
I <sub>C</sub>	Collector current (DC)		5	A
I <sub>CM</sub>	Collector current-Peak		10	A
P <sub>C</sub>	Collector dissipation	T <sub>C</sub> =25°C	40	W
T <sub>j</sub>	Junction temperature		150	°C
T <sub>stg</sub>	Storage temperature		-50~150	°C

## Silicon NPN Power Transistors

## 2SD772 2SD772A 2SD772B

## CHARACTERISTICS

T<sub>j</sub>=25°C unless otherwise specified

SYMBOL	PARAMETER	CONDITIONS	MIN	TYP.	MAX	UNIT	
V <sub>CEQ(SUS)</sub>	Collector-emitter sustaining voltage	I <sub>C</sub> =0.2A; L=25mH	80			V	
V <sub>CEsat</sub>	Collector-emitter saturation voltage	I <sub>C</sub> =5A; I <sub>B</sub> =1A			1.6	V	
V <sub>BE</sub>	Base-emitter on voltage	I <sub>C</sub> =5A; V <sub>CE</sub> =4V			1.5	V	
I <sub>CBO</sub>	Collector cut-off current	2SD772			1.0	mA	
		2SD772A					V <sub>CB</sub> =150V; I <sub>E</sub> =0
		2SD772B					V <sub>CB</sub> =200V; I <sub>E</sub> =0
I <sub>EBO</sub>	Emitter cut-off current	V <sub>EB</sub> =6V; I <sub>C</sub> =0			0.1	mA	
h <sub>FE</sub>	DC current gain	I <sub>C</sub> =5A; V <sub>CE</sub> =4V	14				
t <sub>f</sub>	Fall time	I <sub>C</sub> =5A; V <sub>EB</sub> =-5V, I <sub>B1</sub> =0.8A			1	μs	
f <sub>T</sub>	Transition frequency	I <sub>C</sub> =0.5A; V <sub>CE</sub> =10V		40		MHz	

Silicon NPN Power Transistors

2SD772 2SD772A 2SD772B

PACKAGE OUTLINE

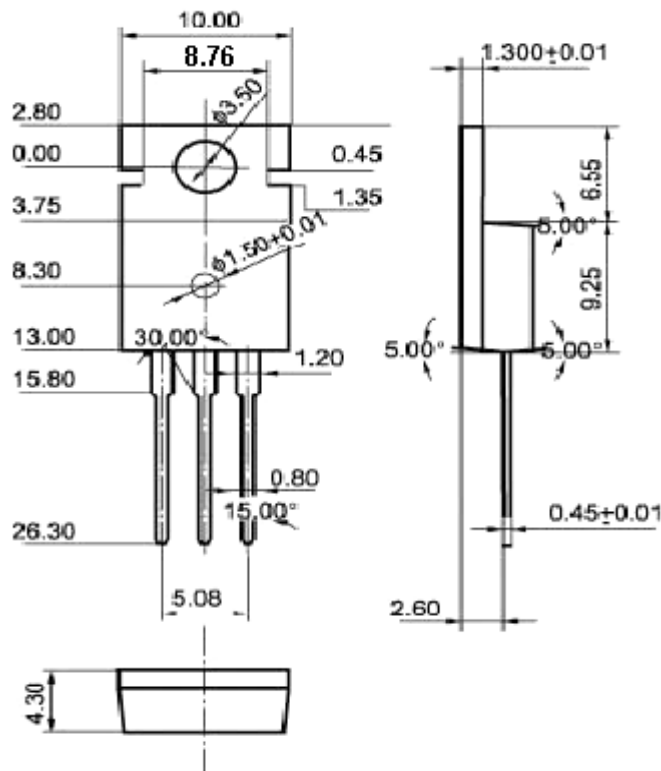

Fig.2 Outline dimensions (unindicated tolerance:  $\pm 0.10\text{mm}$ )