

SavantIC Semiconductor

Product Specification

Silicon PNP Power Transistors

BD136 BD138 BD140

DESCRIPTION

- With TO-126 package
- High current
- Complement to type BD135/137/139

APPLICATIONS

- Driver stages in high-fidelity amplifiers and television circuits

PINNING

PIN	DESCRIPTION
1	Emitter
2	Collector;connected to mounting base
3	Base

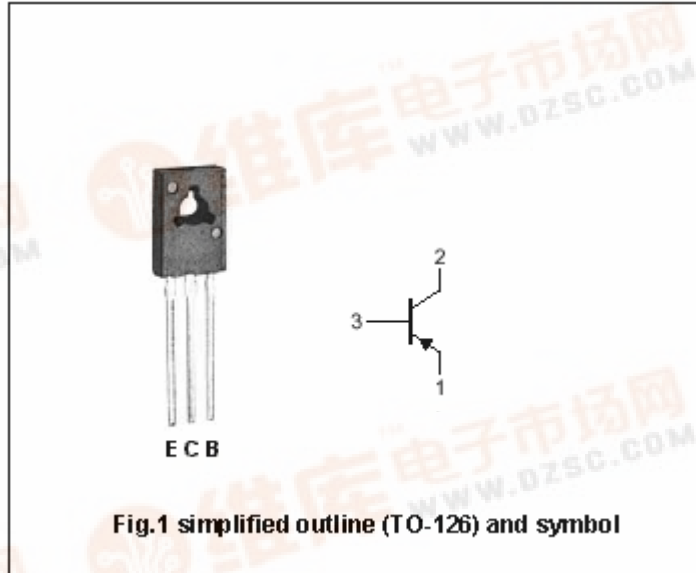

Absolute maximum ratings (Ta=25°C)

SYMBOL	PARAMETER	CONDITIONS	VALUE	UNIT
V <sub>CBO</sub>	Collector-base voltage	BD136	-45	V
		BD138	-60	
		BD140	-100	
V <sub>CEO</sub>	Collector-emitter voltage	BD136	-45	V
		BD138	-60	
		BD140	-100	
V <sub>EBO</sub>	Emitter -base voltage	Open collector	-5	V
I <sub>C</sub>	Collector current (DC)		-1.5	A
I <sub>CM</sub>	Collector current-Peak		-2	A
I <sub>BM</sub>	Base current-Peak		-1	A
P <sub>t</sub>	Total power dissipation	T <sub>mb</sub> ≤70°C	8	W
T <sub>j</sub>	Junction temperature		150	°C
T <sub>stg</sub>	Storage temperature		-65~150	°C
T <sub>amb</sub>	Operating ambient temperature		-65~150	°C

THERMAL CHARACTERISTICS

SYMBOL	PARAMETER	VALUE	UNIT
R <sub>th j-a</sub>	Thermal resistance from junction to ambient	100	K/W
R <sub>th j-mb</sub>	Thermal resistance from junction to mounting base	10	K/W



## Silicon PNP Power Transistors

## BD136 BD138 BD140

## CHARACTERISTICS

T<sub>j</sub>=25°C unless otherwise specified

SYMBOL	PARAMETER	CONDITIONS	MIN	TYP.	MAX	UNIT
V <sub>CEsat</sub>	Collector-emitter saturation voltage	I <sub>C</sub> =-0.5A; I <sub>B</sub> =-50mA			-0.5	V
V <sub>BE</sub>	Base-emitter voltage	I <sub>C</sub> =-500mA; V <sub>CE</sub> =-2V			-1.0	V
I <sub>CBO</sub>	Collector cut-off current	V <sub>CB</sub> =-30V; I <sub>E</sub> =0			-100	nA
		V <sub>CB</sub> =-30V; I <sub>E</sub> =0 T <sub>j</sub> =125°C			-10	μA
I <sub>EBO</sub>	Emitter cut-off current	V <sub>EB</sub> =-5V; I <sub>C</sub> =0			-100	nA
h <sub>FE-1</sub>	DC current gain	I <sub>C</sub> =-5mA; V <sub>CE</sub> =-2V	40			
h <sub>FE-2</sub>	DC current gain BD136-10;BD138-10;BD140-10 BD136-16;BD138-16;BD140-16	I <sub>C</sub> =-150mA; V <sub>CE</sub> =-2V	63 63 100		250 160 250	
h <sub>FE-3</sub>	DC current gain	I <sub>C</sub> =-500mA; V <sub>CE</sub> =-2V	25			
f <sub>T</sub>	Transition frequency	I <sub>C</sub> =-50mA; V <sub>CE</sub> =-5V; f=100MHz		160		MHz

Silicon PNP Power Transistors

BD136 BD138 BD140

PACKAGE OUTLINE

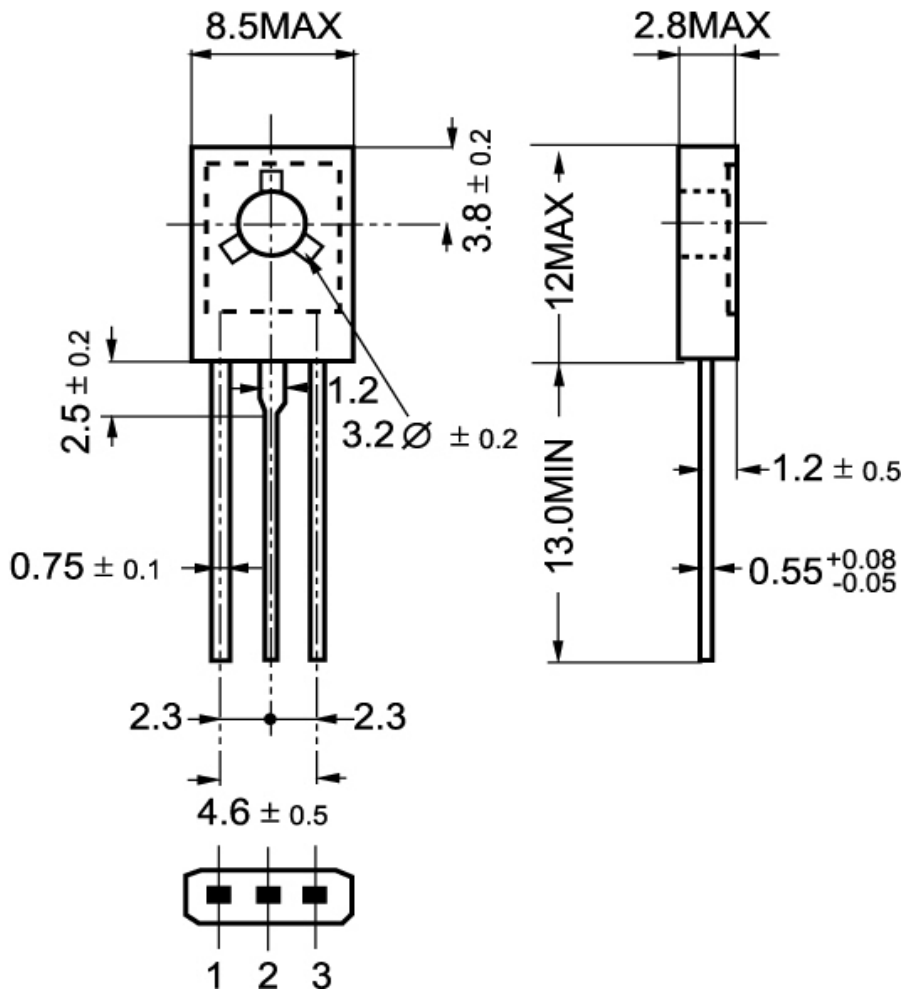

Fig.2 Outline dimensions